

# Brooks® Oval Flowmeters, BM Oval Series, Models BM04 Through BM50



# Essential Instructions

## Read this page before proceeding!

Brooks Instrument designs, manufactures and tests its products to meet many national and international standards. Because these instruments are sophisticated technical products, you must properly install, use and maintain them to ensure they continue to operate within their normal specifications. The following instructions must be adhered to and integrated into your safety program when installing, using and maintaining Brooks Products.

- Read all instructions prior to installing, operating and servicing the product. If this instruction manual is not the correct manual, please see back cover for local sales office contact information. Save this instruction manual for future reference.
- If you do not understand any of the instructions, contact your Brooks Instrument representative for clarification.
- Follow all warnings, cautions and instructions marked on and supplied with the product.
- Inform and educate your personnel in the proper installation, operation and maintenance of the product.
- Install your equipment as specified in the installation instructions of the appropriate instruction manual and per applicable local and national codes. Connect all products to the proper electrical and pressure sources.
- To ensure proper performance, use qualified personnel to install, operate, update, program and maintain the product.
- When replacement parts are required, ensure that qualified people use replacement parts specified by Brooks Instrument. Unauthorized parts and procedures can affect the product's performance and place the safe operation of your process at risk. Look-alike substitutions may result in fire, electrical hazards or improper operation.
- Ensure that all equipment doors are closed and protective covers are in place, except when maintenance is being performed by qualified persons, to prevent electrical shock and personal injury.

## Pressure Equipment Directive (PED)

All pressure equipment with an internal pressure greater than 0.5 bar (g) and a size larger than 25mm or 1" (inch) falls under the Pressure Equipment Directive (PED). The Directive is applicable within the European Economic Area (EU plus Norway, Iceland and Liechtenstein). Pressure equipment can be traded freely within this area once the PED has been complied with.

- Section 1 of this manual contains important safety and operating instructions related to the PED directive.
- Meters described in this manual are in compliance with EN directive 97/23/EC module H *Conformity Assessment*.
- All Brooks Instrument Flowmeters fall under fluid group 1.
- Meters larger than 25mm or 1" (inch) are in compliance with category I, II, III of PED.
- Meters of 25mm or 1" (inch) or smaller are Sound Engineering Practice (SEP).

## ESD (Electrostatic Discharge)

### CAUTION

**This instrument contains electronic components that are susceptible to damage by static electricity. proper handling procedures must be observed during the removal, installation or other handling of internal circuit boards or devices.**

#### Handling Procedure:

1. Power to unit must be removed.
2. Personnel must be grounded, via a wrist strap or other safe, suitable means before any printed circuit card or other internal device is installed, removed or adjusted.
3. Printed circuit cards must be transported in a conductive container. Boards must not be removed from protective enclosure until immediately before installation. Removed boards must immediately be placed in protective container for transport, storage or return to factory.

#### Comments

This instrument is not unique in its content of ESD (electrostatic discharge) sensitive components. Most modern electronic designs contain components that utilize metal oxide technology (NMOS, SMOS, etc.). Experience has proven that even small amounts of static electricity can damage or destroy these devices. Damaged components, even though they appear to function properly, exhibit early failure.

## Installation and Operation Manual

X-PD-BM-Ovals-eng

Part Number: 541B031AAG

January, 2009

BM Oval Series

---

Dear Customer,

We appreciate this opportunity to service your flow measurement and control requirements with a Brooks Instrument device. Every day, flow customers all over the world turn to Brooks Instrument for solutions to their gas and liquid low-flow applications. Brooks provides an array of flow measurement and control products for various industries from biopharmaceuticals, oil and gas, fuel cell research and chemicals, to medical devices, analytical instrumentation, semiconductor manufacturing, and more.

The Brooks product you have just received is of the highest quality available, offering superior performance, reliability and value to the user. It is designed with the ever changing process conditions, accuracy requirements and hostile process environments in mind to provide you with a lifetime of dependable service.

We recommend that you read this manual in its entirety. Should you require any additional information concerning Brooks products and services, please contact your local Brooks Sales and Service Office listed on the back cover of this manual or visit [www.BrooksInstrument.com](http://www.BrooksInstrument.com)

Yours sincerely,

Brooks Instrument

*THIS PAGE WAS  
INTENTIONALLY  
LEFT BLANK*

<u>Paragraph Number</u>	<u>Page Number</u>
<b>Section 1 Introduction</b>	
1-1 Purpose .....	1-1
1-2 Description .....	1-1
1-3 Specifications .....	1-1
1-4 Display Options .....	1-5
1-5 Accessories and Options .....	1-8
<b>Section 2 Installation</b>	
2-1 General .....	2-1
2-2 Receipt of Equipment .....	2-1
2-3 Recommended Storage Practice .....	2-1
2-4 Return Shipment .....	2-2
2-5 Transit Precautions .....	2-2
2-6 Installation .....	2-2
2-7 Pre-Operation Procedures .....	2-5
<b>Section 3 Operation</b>	
3-1 General .....	3-1
3-2 Flowmeter Principle of Operation .....	3-1
3-3 Pulse Generator Principle of Operation .....	3-2
3-4 Operating Instructions .....	3-2
3-5 Operating Precautions .....	3-3
3-6 Precautions at Operation Shutdown .....	3-3
3-7 Operation of Standard LC Display .....	3-4
3-8 Deluxe LCD Display Description .....	3-13
3-9 Deluxe LCD Specifications .....	3-15
3-10 Deluxe LCD Operation .....	3-16
<b>Section 4 Maintenance</b>	
4-1 General .....	4-1
4-2 Manufacturer's Maintenance Recommendations .....	4-1
4-3 Disassembly - General .....	4-2
4-4 Disassembly - Flowmeter (Refer to Figure 5-1) .....	4-3
4-5 Cleaning .....	4-4
4-6 Assembly - Flowmeter .....	4-4
4-7 Battery Replacement .....	4-5
4-8 General Maintenance for the General Display .....	4-6
4-9 Troubleshooting .....	4-9
<b>Section 5 Parts List</b>	
5-1 General .....	5-1
<b>Warranty, Local Sales/Service Contact Information .....</b>	<b>Back Cover</b>

BM Oval Series

Figures

<b>Figure Number</b>	<b>Page Number</b>
1-1 Dimensions .....	1-4
1-2 Standard LCD Display .....	1-5
1-3 Deluxe LCD Display .....	1-6
1-4 Mechanical Display .....	1-7
2-1 Proper Orientation of Meter Assembly .....	2-2
2-2 Hall Effect Sensor Connections .....	2-3
2-3 Reed Switch Connections for PCB Terminals .....	2-4
2-4 4-20 mA Loop Powered Transmitter .....	2-4
2-5 Horizontal Installation .....	2-5
2-6 Vertical Installation .....	2-6
3-1 Principle of Operation .....	3-1
3-2a Control Panel .....	3-4
3-2b BM10 Atandard LCD Display .....	3-4
3-2c Control Panel Display .....	3-5
3-3 Control Panel Display, Example of Function .....	3-6
3-4 Terminal Connectors .....	3-10
3-5 Pulse-Signal NPN/PNP .....	3-11
3-6 Reed-Switch .....	3-11
3-7 Batch Control Diagram .....	3-13
3-8 Deluxe LCD .....	3-14
3-9 Locations and Functions of Meter Keys .....	3-15
3-10 Operation View (Normal Mode) .....	3-16
3-11 Cancel Total Quality (Normal Mode) .....	3-16
3-12 Display of Flowrate (Normal Mode) .....	3-16
3-13 Operation View (Automatic Mode) .....	3-17
3-14 Display of Flowrate (Automatic Mode) .....	3-17
3-15 Display of Operation (View Mode) .....	3-18
3-16 Calibration Constant .....	3-19
3-17 Select Measuring Unit .....	3-20
3-18 Connections Diagram .....	3-20
3-19 Amplifier Diagram .....	3-21
3-20 Example Application #1 .....	3-21
3-21 Example Application #2 .....	3-22
3-22 Example Application #3 .....	3-23
4-1 Rotor Positions .....	4-3
4-2 Deluxe LCD Display Assembly Parts .....	4-6
4-3 Deluxe LCD Display Assembly Parts .....	4-6
5-1 Exploded Parts Drawing for Model BM04 Pulse Meter .....	5-2
5-2 Exploded Parts Drawing for Model BM07 Pulse Meter .....	5-3
5-3 Exploded Parts Drawing for Model BM04 Pulse Meter .....	5-4
5-4 Exploded Parts Drawing for Model BM10 Pulse Meter .....	5-5
5-5 Exploded Parts Drawing for Model BM40 Pulse Meter .....	5-6
5-6 Exploded Parts Drawing for Model BM50 Pulse Meter .....	5-7
5-7 Exploded Parts Drawing for Models BM10/BM40/BM50 .....	5-8
5-8 Exploded Parts Drawing for Model BM10 Mechanical Meter .....	5-9
5-9 Exploded Parts Drawing for Model BM40 Mechanical Meter .....	5-11
5-10 Exploded Parts Drawing for Model BM50 Mechanical Meter .....	5-13

**Tables**

<u>Table Number</u>	<u>Page Number</u>
1-1 Capacities .....	1-1
1-2 Maximum Working Pressures and Temperatures .....	1-2
1-3 K-Factors .....	1-2
1-4 Materials of Construction .....	1-3
1-5 Connections .....	1-3
1-6 Recommended Strainer Sizes .....	1-8
1-7 Optional Accessories .....	1-8
1-8 Higher Viscosity Coefficient Factors .....	1-8
1-9 Model Codes .....	1-9
1-10 Weights .....	1-9
2-1 Max. Particle Size and Recommended Strainer Mesh .....	2-3
3-1 Setup .....	3-9
3-2 Fault Indicator .....	3-19
3-3 Summary Table for Normal Operation .....	3-23
3-4 Summary Table for Automatic Operation .....	3-23
4-1 Troubleshooting .....	4-10

BM Oval Series

---

*THIS PAGE WAS  
INTENTIONALLY  
LEFT BLANK*

### 1-1 Purpose

The Brooks® BM Series Flowmeters, hereafter called flowmeters, are positive displacement meters that measure extremely low flows of clean liquid with high accuracy. The flowmeter generates an electrical signal proportional to flow for use with a wide variety of electronic instrumentation.

### 1-2 Description

The flowmeters have incorporated the oval rotor principle into its design. This has proven to be a reliable and highly accurate method of measuring flow. Exceptional repeatability and high accuracy over a wide range of viscosities and flow rates are features of the flowmeters.

The low pressure drop and high pressure rating means the flowmeters are suitable for both gravity and pump (in line) applications.

### 1-3 Specifications

#### ⚠ WARNING

**Do not operate this instrument in excess of the specifications listed below. Failure to heed this warning can result in serious personal injury and/or damage to the equipment.**

**Capacities** (See Table 1-1): Capacities,  
 For capacities with higher viscosity, (Refer to Table 1-8)

Table 1-1 Capacities

Viscosity	Model				
	BM04	BM07	BM10	BM40	BM50
< 5cp	.79 to 6.6 gpm (3 to 25 lpm)	2 to 18.5 gpm (8 to 70 lpm)	2.6 to 26 gpm (10 to 100 lpm)	4 to 62 gpm (15 to 235 lpm)	7.93 to 79.25 gpm (30 to 300 lpm)
5 to 1000cp	.26 to 7.93 gpm (1 to 30 lpm)	.8 to 21 gpm (3 to 80 lpm)	1.6 to 32 gpm (6 to 120 lpm)	2.6 to 66 gpm (10 to 250 lpm)	3.96 to 92.46 gpm (15 to 350 lpm)

#### Performance

Accuracy:

+/-0.5% when viscosity is >5 cP

+/-1% when viscosity is <5 cP

#### Pressure Drop

<3 psi at full scale flow when viscosity is 1 cP or less and not more than 15 psi at 1000 cP.

#### Ratings:

Maximum working pressure: See Table 2 Maximum working temperature:

See Table 2 Ambient Temperature: -4° F to 104° F (-20° C to +40° C)

Meter sizes BM04, BM07, BM10 & BM50 have been subjected to a 4 times maximum working pressure test. Meter size BM40 has been subjected to a 3 times maximum working pressure test.

#### Pressure Equipment Directive (97/23/EL) Meter Classifications - PED

Model	PED Category
BM01/02	SEP
BM04	SEP
BM07	SEP
BM10	SEP
BM40	Category 1
BM50	Category 1

## BM Oval Series

Table 1-2 Maximum Working Pressures and Temperatures

Materials		MODELS					
		BM04, BM10		BM40, BM50*		BM07	
Body	Rotors(Gears)	Max. Press. PSIG(kPa)	Max Temp. F(C)	Max. Press. PSIG(kPa)	Max Temp. F(C)	Max. Press. PSIG(kPa)	Max Temp. F(C)
Aluminum, Screwed	PPS	800(5500)	176(80)	260(1792)	176(80)	N/A	N/A
Aluminum, Flanged, 150 lb	PPS	275(1896)	176(80)	260(1792)	176(80)	N/A	N/A
Aluminum, Screwed	316 Stainless Stl.	800(5500)	248(120)	260(1792)	248(120)	N/A	N/A
Aluminum, Flanged, 150 lb.	316 Stainless Stl.	275(1896)	248(120)	260(1792)	248(120)	N/A	N/A
316SS, Screwed	PPS	800(5500)	176(80)	260(1792)	176(80)	N/A	N/A
316SS, Flanged, 150 lb.	PPS	275(1896)	176(80)	260(1792)	176(80)	N/A	N/A
316SS, Screwed	316 Stainless Stl.	800(5500)	248(120)	260(1792)	248(120)	N/A	N/A
316SS, Flanged, 150 lb.	316 Stainless Stl.	275(1896)	248(120)	260(1792)	248(120)	N/A	N/A
316 SS, Tri-Clover	316 Stainless Stl.	See BM10 Tri-Clover below		N/A	N/A	N/A	N/A
PPS, Screwed only	PPS	N/A	N/A	N/A	N/A	150(1000)	176(80)
Bronze, Screwed only	PPS	See BM10 Bronze Body Below		N/A	N/A	N/A	N/A

Materials		MODELS			
		BM10 Tri-Clover		BM10, BRONZE BODY	
Body	Rotors(Gears)	Max. Press. PSIG(kPa)	Max Temp. F(C)	Max. Press. PSIG(kPa)	Max Temp. F(C)
316 SS, Tri-Clover	316 Stainless Stl.	150(1000)	176(80)	N/A	N/A
Bronze, Screwed only	PPS	N/A	N/A	800(5500)	176(80)

\* BM50 available with flanges only.

**Notes:**

The maximum pressure with mechanical display limits above applications to 500 psig (3450 kPa) or the lesser of the meter listed. All pressures listed are at 100° F (38° C) for higher temperatures, pressure will be reduced per the standard flange specification ANSI B16.5.

**Ambient temperature:** -4°F to 104°F (-20°C - +40°C)

Meter sizes BM04, BM07, BM10 & BM50 have been subjected to a 4 times maximum working pressure test.

Meter size BM04 has been subjected to a 3 times maximum working pressure test.

**Outputs****Reed Switch**

Detection Method: Reed Switch, Two wire SPST N/O contact.

Max. Voltage: 150 Vdc maximum.

Contact Capacity: 0.25 AMPS

Rating 3 Watts

**Hall Effect Switch**

Detection Method: Hall effect switch

Response Frequency: 1,000 Hz maximum

Output Pulse: Unfactored voltage pulse

Input/Output = 4.5 to 24 Vdc (4.6 ~ 9 mA)

Open Collector 25 mA output NPN compatible with digital logic.

Reverse power protection.

(Refer to Table 1-3, below)

Nominal K-Factor for both Reed and Hall effect switch:

Table 1-3 K-Factors

Model	K-Factors/Pulse Output Resolution			
	Gallons		Liters	
	Single Switch	Dual Switch	Single Switch	Dual Switch
<b>BM04</b>	424.3	848.6	112	224
<b>BM07</b>	197	394	52	104
<b>BM10</b>	136.3	272.6	36	72
<b>BM40</b>	54.9	109.8	14.5	29
<b>BM50</b>	25.29	50.58	6.68	13.36

Table 1-4 Materials of Construction

Item	Materials	Meter Model/Size				
		BM04	BM07	BM10	BM40	BM50
<b>Body</b>	PPS	N/A	Standard	N/A	N/A	N/A
	Aluminum	Standard	N/A	Standard	Standard	Standard
	316 Stainless Stl.	Standard	N/A	Standard	Standard	Standard
	Bronze	N/A	N/A	Option	N/A	N/A
<b>Rotor/Gear</b>	PPS	Standard	Standard	Standard	Standard	Standard
	316 Stainless Stl.	Option	N/A	Option	Option	Option
<b>Shaft-Rotor/Gear</b>	316 Stainless Stl.	Standard	Standard	Standard	Standard	Standard
	Hastelloy C	N/A	Option	N/A	N/A	N/A
<b>Cap-Pulse Meter</b>	Aluminum	Standard	N/A	Standard	Standard	Standard
	316 Stainless Stl.	Option	N/A	Option	Option	Option
	PPS	N/A	Standard	N/A	N/A	N/A
<b>O-Ring-Body</b>	Viton®	Standard	Standard	Standard	Standard	Standard
	Teflon®	Option	Option	Option	Option	Option
<b>O-Ring/Seal Mech. Register</b>	Viton	N/A	N/A	Option	Option	Option

Table 1-5 Connections

<b>BM04</b>	1/2 inch NPT
<b>BM07</b>	1 inch NPT
<b>BM10</b>	1 inch NPT
	1 inch 150 Lb RF Flange
	1 inch TriClover
<b>BM40</b>	1 1/2 inch NPT
	1 1/2 inch 150 Lb RF Flange
	1 1/2 inch 300 Lb RF Flange
<b>BM50</b>	2 inch NPT
	2 inch 150 Lb RF Flange

**Electrical Connections**

Pulser cap: 1/2" NPT

**Dimensions**

(Refer to Figure 1-1, on next page)

For certified dimensional prints, contact the factory.

For weights (Refer to Table 1-10)



## 1-4 Display Options

### Standard LCD Display

The standard liquid crystal (LC) display is available on the BM04, BM07, BM10, BM40 and BM50 models.

Features:

- Seven (7) digit x 11/16" (17 mm) Liquid Crystal Display
- Rotatable in 90° increments.
- Selectable flow rate display in U.S. Gallons, Liters, Cubic Meters (M<sub>3</sub>), Milliliters and Barrels
- 2 total displays - resettable and non-resettable, up to 999999.99 units ( gallons or liters )
- Programmable calibration constant ( K-factor )
- Long life lithium battery Pulse output of ancillary equipment



Figure 1-2 Standard LCD Display

---

BM Oval Series

---

**Deluxe LCD Display**

The deluxe liquid crystal (LC) display is available on the models BM04, BM07, BM10, BM40 and BM50 models.

## Features:

- Seven (7) digit x 1/2" (12.7 mm) Liquid Crystal Display
- Rotatable in 90° increments
- Selectable flow rate display in U.S. Gallons or Liters (according to model selected)
- 2 total displays - resettable and non-resettable, up to 999999.99 units (gallons or liters)
- Factory set calibration constant (K-factor)
- Additional nine (9) calibration constants (K-factors) available for "in the field" settings
- Long life lithium battery
- Extended life battery available as option
- Pulse output on ancillary equipment
- Approved for hazardous locations when used with standard battery for EExia IIC T6 (PTB nr. Ex-93.C 4033X)
- Presettable batch control function up to 9,999 units (99.99, 999.9, 0r 9,999 optional settings)
- Ten (10) preset batch quantity storage capacity.
- Single or dual valve actuation output to be used with add on trip amplifier

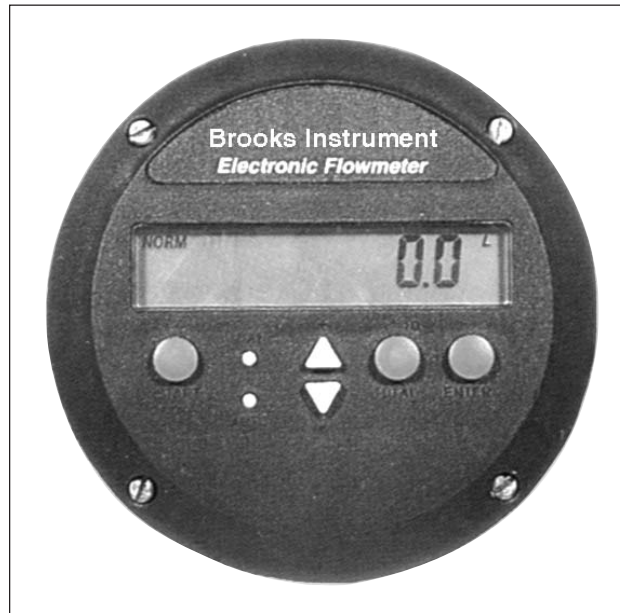

Figure 1-3 Deluxe LCD Display

### Mechanical Display

The mechanical display is available on the BM04, BM10, BM40 and BM50 models.

#### Features:

- U.S. Gallons or Liters
- 2 total displays 1 to 9,999 liters or 1/10 to 999.9 U.S. Gallons (resettable) 1 to 999;999 Liters (X10) or 1 to 999,999 U.S. Gallons (non-resettable)
- Push button reset
- Rotatable in 90° increments

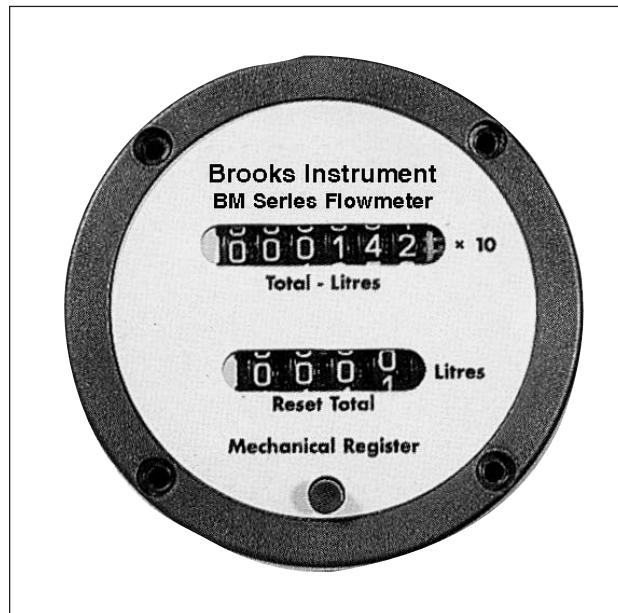

Figure 1-4 Mechanical Display

BM Oval Series

1-5 Accessories and Options

(Refer to Table 1-7)

- Standard LCD Display
- Deluxe LCD Display
- Mechanical Register
- High Viscosity Rotors (gears)
- High Temperature Rotors (gears)
- Heating Jacket
- Recommended Strainer Sizes, (Refer to table 1-6)

Table 1-6 Recommended Strainer Sizes

Strainer Recommendations		
Model	Max Partical Size	Strainer Size
BM04	0.011" (0.28mm)	60 Mesh
BM07	0.011" (0.28mm)	60 Mesh
BM10	0.011" (0.28mm)	60 Mesh
BM40	0.015" (0.38mm)	60 Mesh
BM50	0.018" (0.46mm)	60 Mesh

Table 1-7 Optional Accessories

Optional Accessories					
Available on Models	Standard LCD Display	Deluxe LCD Display	Mechanical Register	High Viscosity Rotors (Gears)	High Temp Rotors (Gears)
BM04	Yes	Yes	Yes	PPS or 316 SS	PPS
BM07	Yes	Yes	N/A	PPS Only	N/A
BM10	Yes	Yes	Yes	PPS or 316 SS	PPS
BM40	Yes	Yes	Yes	PPS or 316 SS	PPS
BM50	Yes	Yes	Yes	PPS or 316 SS	PPS

Table 1-8 Higher Viscosity Coefficient Factors

Coefficient Factors	Viscosity	Models									
		BM04		BM07		BM10		BM40		BM50	
		GPM	LPM	GPM	LPM	GPM	LPM	GPM	LPM	GPM	LPM
1	< 2500 cP	9.3	35.0	21.1	80.0	31.7	120.0	66.1	250.0	92.5	350.0
0.9	< 3000 cP	8.3	31.5	19.0	72.0	28.5	108.0	59.5	225.0	83.2	315.0
0.8	< 4000 cP	7.4	28.0	16.9	64.0	25.4	98.0	52.8	200.0	74.0	280.0
0.7	< 5000 cP	6.5	24.5	14.8	56.0	22.2	84.0	46.2	175.0	64.7	245.0
0.6	< 8000 cP	5.6	21.0	11.8	48.0	19.0	72.0	39.6	150.0	55.5	210.0
0.5	< 12000 cP	4.6	17.5	10.6	40.0	15.9	60.0	33.0	125.0	46.2	175.0
0.4	< 25000 cP	3.7	14.0	8.5	32.0	12.7	48.0	26.4	100.0	37.0	140.0
0.3	< 40000 cP	2.8	10.5	6.3	24.0	9.5	36.0	19.8	75.0	27.4	105.0
0.2	< 95000 cP	1.9	7.0	4.2	16.0	6.3	24.0	13.2	50.0	18.5	70.0
0.1	< 450000 cP	0.9	3.5	2.1	8.0	3.2	12.0	6.6	25.0	9.3	35.0
0.05	< 1000000 cP	0.5	1.8	1.1	4.0	1.6	6.0	3.3	12.5	4.6	17.5

Table 1-9 Model Codes

MODEL	BASIC MODEL						
BM	BROOKS-OVAL						
	CODE	NOMINAL SIZE					
	04	1/2 INCH					
	07	1 INCH					
	10	1 INCH					
	40	1 1/2 INCH					
	50	2 INCH					
	CODE	REVISION					
	A	CURRENT REVISION					
	CODE	BODY MATERIAL					
	A	ALUMINUM					
	B	BRONZE (BM10 METER ONLY)					
	R	PPS (BM7 METER ONLY)					
	S	316 STAINLESS STEEL					
	CODE	ROTOR/GEAR MATERIAL					
	R	PPS ROTOR (GEAR) SET					
	S	316 STAINLESS STEEL ROTOR (GEAR) SET					
	CODE	PULSER/DISPLAY					
	P	PULSE OUTPUT					
	E	DELUXE LCD DISPLAY (PROGRAMMABLE, GALLONS OR LITERS)					
	F	STANDARD LCD DISPLAY, (PROGRAMMABLE, GALLONS OR LITERS)					
	M	MECHANICAL REGISTER, GALLONS, REGISTRATION					
	N	MECHANICAL REGISTER, LITERS REGISTRATION					
	CODE	CONNECTION TYPE	AVAILABLE ON METER MODEL/SIZES				
			BM04	BM07	BM10	BM40	BM50
	2	NPT	YES	YES	YES	YES	YES
	4	150 # RF	N/A	N/A	YES	YES	YES
	5	DIN 16	N/A	N/A	N/A	YES	N/A
	7	TRICLOVER	N/A	N/A	YES	N/A	N/A
	8	300 # RF	N/A	N/A	N/A	YES	N/A
	CODE	OUTPUT/ELECTRONIC					
	R	REED SWITCH (STANDARD)					
	H	HALL EFFECT (OPTIONAL)					
	N	NONE (MECHANICAL REGISTER OPTION)					
	CODE	VISCOSITY					
	1	STANDARD <1000 CP (ALL ROTOR (GEAR) MATERIALS)					
	2	HIGH > 1000 CP, PPS ROTORS (GEARS)					
	3	HIGH > 1000 CP, STAINLESS STEEL ROTOR (GEARS)					
	CODE	TEMPERATURE CLASS					
	A	STANDARD TEMP. PPS ROTORS (GEARS), 80C / 176F					
	B	HIGH TEMP. PPS ROTORS (GEARS), 120C / 248F					
	C	STANDARD TEMP. SS ROTORS (GEARS) 120C / 248F					
	CODE	SEALS/O-RINGS					
	V	VITON					
	K	TEFLON					
	CODE	OPTIONS					
	A	NONE (STANDARD METERS)					
	C	HASTALLOY C SHAFTS, BM07 METER ONLY.					
	S	SOLVENT KIT, ALUM MECH METERS					
	CODE	APPROVALS/CERTIFICATIONS					
	A	NONE					

BM 10 A A R P 2 R 1 A V A A

Table 1-10 Weights

Model	Connection	Body Material		
		Alum	PPS	316 SS
BM04	Screwed	3 lbs (1.4 kg)	N/A	6 lbs (2.7 kg)
BM07	Screwed	N/A	3 lbs (1.4kg)	N/A
BM10	Screwed	6 lbs (2.7 kg)	N/A	10 lbs (4.6 kg)
BM10	Flanged	10 lbs (4.6kg)	N/A	14 lbs (6.3 kg)
BM40	Screwed	11 lbs (5 kg)	N/A	19 lbs (8.6 kg)
BM40	Flanged	13 lbs (5.9 kg)	N/A	21 lbs (9.6 kg)
BM50	Flanged	16 lbs 7.3 kg)	N/A	42 lbs (19.1 kg)

*THIS PAGE WAS  
INTENTIONALLY  
LEFT BLANK*

## Installation 2-1 General

This section contains the procedures for the receipt and installation of the flowmeter. Do not attempt to start the system until the flowmeter has been permanently installed. It is extremely important that the start-up procedures be followed in the exact sequence presented.

### CAUTION

**Permanent damage to the flowmeter components may result unless the procedures are followed.**

## 2-2 Receipt of Equipment

When the instrument is received, the outside packing case should be checked for damage incurred during shipment. If the packing case is damaged, the local carrier should be notified at once regarding his liability. A report should be submitted to your nearest Product Service Department.

### Brooks Instrument

407 W. Vine Street  
P.O. Box 903  
Hatfield, PA 19440 USA  
Toll Free (888) 554-FLOW (3569)  
Tel (215) 362-3700  
Fax (215) 362-3745  
E-mail: BrooksAm@BrooksInstrument.com  
www.BrooksInstrument.com

### Brooks Instrument

Neonstraat 3  
6718 WX Ede, Netherlands  
P.O. Box 428  
6710 BK Ede, Netherlands  
Tel 31-318-549-300  
Fax 31-318-549-309  
E-mail: BrooksEu@BrooksInstrument.com

### Brooks Instrument

1-4-4 Kitasuna Koto-Ku  
Tokyo, 136-0073 Japan  
Tel 011-81-3-5633-7100  
Fax 011-81-3-5633-7101  
Email: BrooksAs@BrooksInstrument.com

Remove the envelope containing the packing list. Carefully remove the instrument from the packing case. Make sure spare parts are not discarded with the packing materials. Inspect for damaged or missing parts.

## 2-3 Recommended Storage Practice

If intermediate or long-term storage is required equipment, as supplied by Brooks Instrument, it is recommended that the equipment be stored in accordance with the following:

- a. Within the original shipping container.
- b. Stored in a sheltered area, preferably a warm, dry, heated warehouse.
- c. Ambient temperature of 70° F (21° C) nominal, 109° F (43° C) maximum, 45° F (7° C) minimum.
- d. Relative humidity 45% nominal, 60% maximum, 25% minimum.  
Upon removal from storage a visual inspection should be conducted to verify the condition of equipment is "as received".

BM Oval Series

2-4 Return Shipment

Prior to returning any instrument to the factory visit the Brooks website [www.BrooksInstrument.com](http://www.BrooksInstrument.com) for a Return Materials Authorization Number (RMA#), or contact one of the following locations:

**Brooks Instrument**

407 W. Vine Street  
 P.O. Box 903  
 Hatfield, PA 19440 USA  
 Toll Free (888) 554-FLOW (3569)  
 Tel (215) 362-3700  
 Fax (215) 362-3745  
 E-mail: [BrooksAm@BrooksInstrument.com](mailto:BrooksAm@BrooksInstrument.com)  
[www.BrooksInstrument.com](http://www.BrooksInstrument.com)

**Brooks Instrument**

Neonstraat 3  
 6718 WX Ede, Netherlands  
 P.O. Box 428  
 6710 BK Ede, Netherlands  
 Tel 31-318-549-300  
 Fax 31-318-549-309  
 E-mail: [BrooksEu@BrooksInstrument.com](mailto:BrooksEu@BrooksInstrument.com)

**Brooks Instrument**

1-4-4 Kitasuna Koto-Ku  
 Tokyo, 136-0073 Japan  
 Tel 011-81-3-5633-7100  
 Fax 011-81-3-5633-7101  
 Email: [BrooksAs@BrooksInstrument.com](mailto:BrooksAs@BrooksInstrument.com)

Instrument must have been purged in accordance with the following:

**! WARNING**

**Before returning the device purge thoroughly with a dry inert gas such as Nitrogen before disconnecting gas connections. Failure to correctly purge the instrument could result in fire, explosion or death. Corrosion or contamination may occur upon exposure to air.**

All flow instruments returned to Brooks requires completion of Form RPR003-1, Brooks Instrument Decontamination Statement, along with a Material Safety Data Sheet (MSDS) for the fluid(s) used in the instrument. Failure to provide this information will delay processing by Brooks personnel. Copies of these forms can be downloaded from the Brooks website [www.BrooksInstrument.com](http://www.BrooksInstrument.com) or are available from any Brooks Instrument location listed above.

2-5 Transit Precautions

To safeguard against damage during transit, transport the meter to the installation site in the same container used for transportation from the factory if circumstances permit.

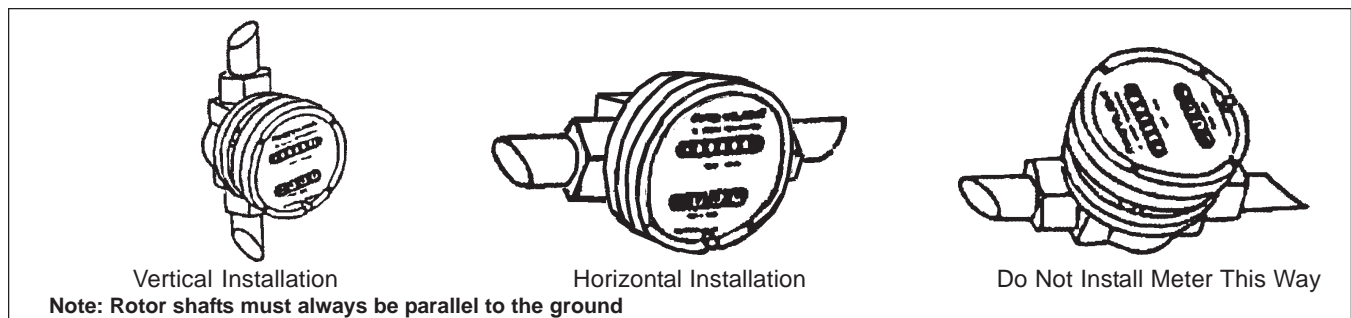

Figures 2-1 Proper Orientation of Meter Assembly.

2-6 Installation

**CAUTION**

Exercise care not to overspeed the meter at this time. By overspeeding the meter, serious damage to the rotor and measuring chamber can result.

To provide for optimum system performances the following guidelines should be observed:

1. Before use, confirm the fluid to be used is compatible with the meter.
2. The flowmeter must be installed so the shafts of the rotors are horizontal, never vertical or "on end". Severe damage to components may be the result, (See Figure 2-1).
3. A mesh strainer should be installed upstream and adjacent to the flowmeter to protect it from foreign matter such as dirt, pipe scale, or welding splatter.

Table 2-1 Maximum Particle Size and Recommended Strainer Mesh

Strainer Recommendations		
Model	Max Partical Size	Strainer Size
BM04	0.011" (0.28mm)	60 Mesh
BM07	0.011" (0.28mm)	60 Mesh
BM10	0.011" (0.28mm)	60 Mesh
BM40	0.015" (0.38mm)	60 Mesh
BM50	0.018" (0.46mm)	60 Mesh

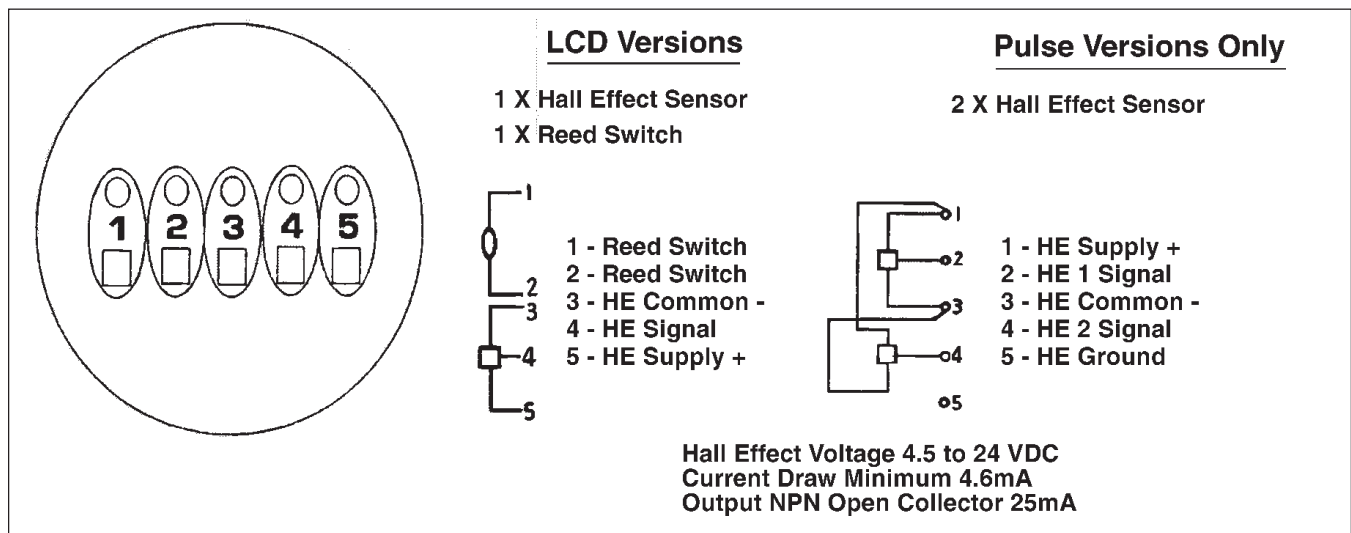

Figure 2-2 Hall Effect Sensor Connections

BM Oval Series

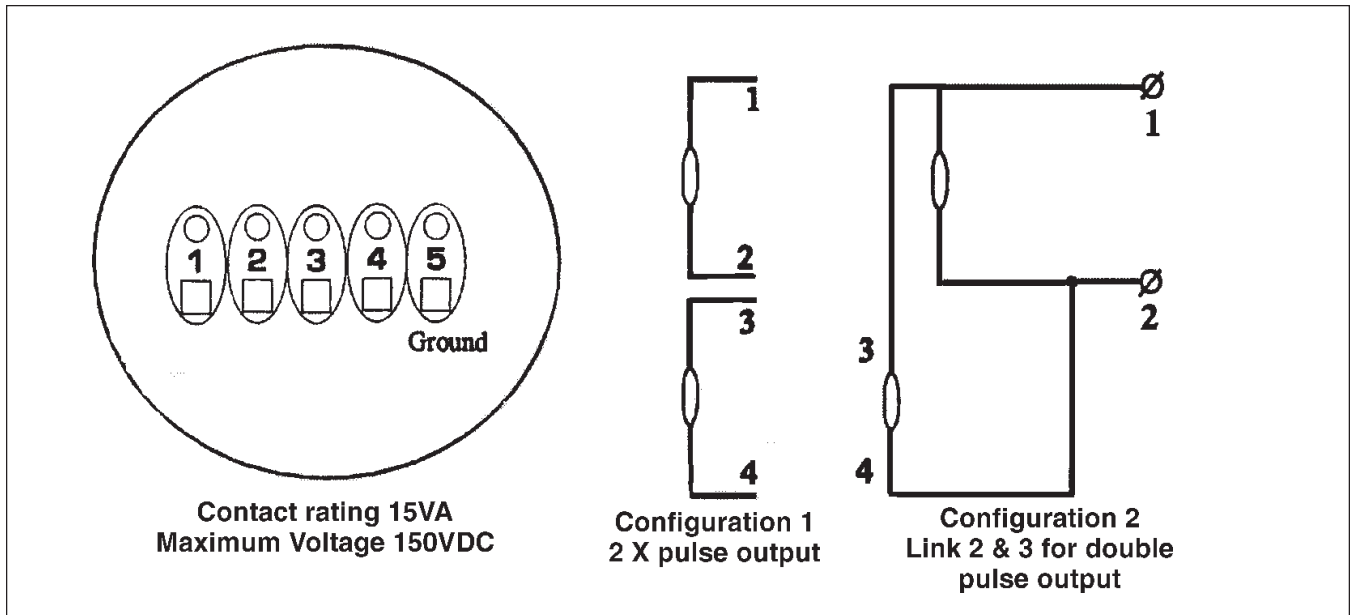

Figure 2-3 Reed Switch Connections for PCB Terminals

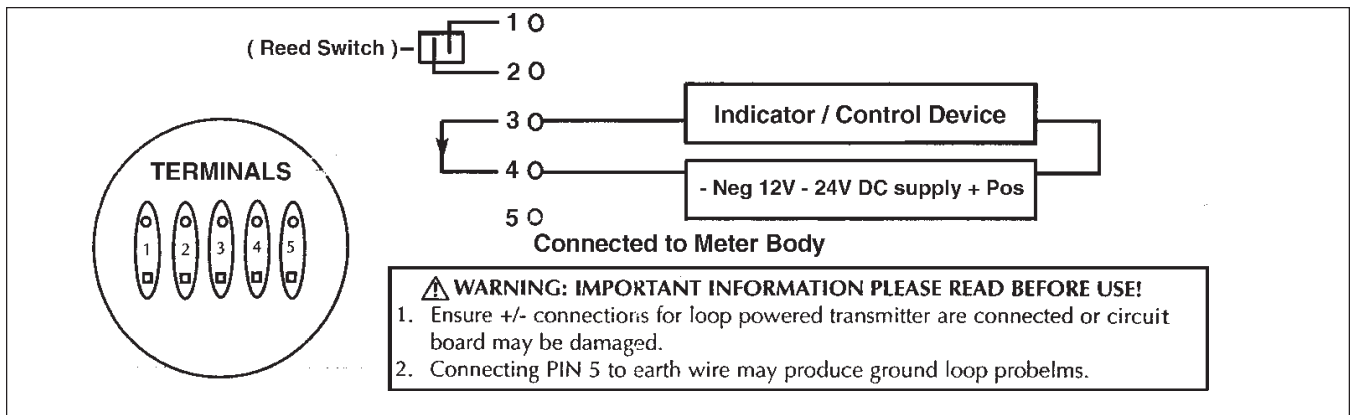

Figure 2-4 4-20 mA Loop Powered Transmitter

**⚠ CAUTION**

Extreme care must be taken when installing the meter. Pipe strain or over tightening meter connections can cause meter damage.

**⚠ CAUTION**

It is important to provide a strainer and to properly maintain it. Failure to do so can result in particles causing the rotors to jam and resulting in blocked fuel flow which can create a hazardous condition such as engine failure when installed on motor vehicle.

(Refer to Table 2-1 for strainer size), ( See Figures 2-5 and 2-6).

4. Valves should be installed to facilitate removal of the flowmeter and strainer, (See Figures 2-4 and 2-5).
5. Install the flowmeter on the discharge side of a pump whenever possible.
6. Before installing the flowmeter, wash and clean the inside of the pipeline with compressed air or steam. This is particularly important on new pipelines.
7. Remove the protective covering from the flowmeter end connectors before installation.
8. When making connection to the flowmeter make certain that no foreign materials enter flowmeter body.
9. Ensure that the meter is installed so that the flow of the liquid is in the direction of the arrows embossed on the meter body.
10. Refer to Figures 2-2, 2-3 or 2-4 for electrical connections.

## 2-7 Pre-Operation Procedures

1. After the flowmeter has been installed, slowly allow the liquid to flow in bypass section of a horizontal installation or the main line of a vertical installation. This will clear the line of any foreign particles.
2. Test the system for leaks.
3. Check the strainer for foreign material, after the first 50 gallons/200 liters check periodically, particularly if the flow rate decreases.

NOTE: Foreign particles in the main line may cause damage to the flowmeter.

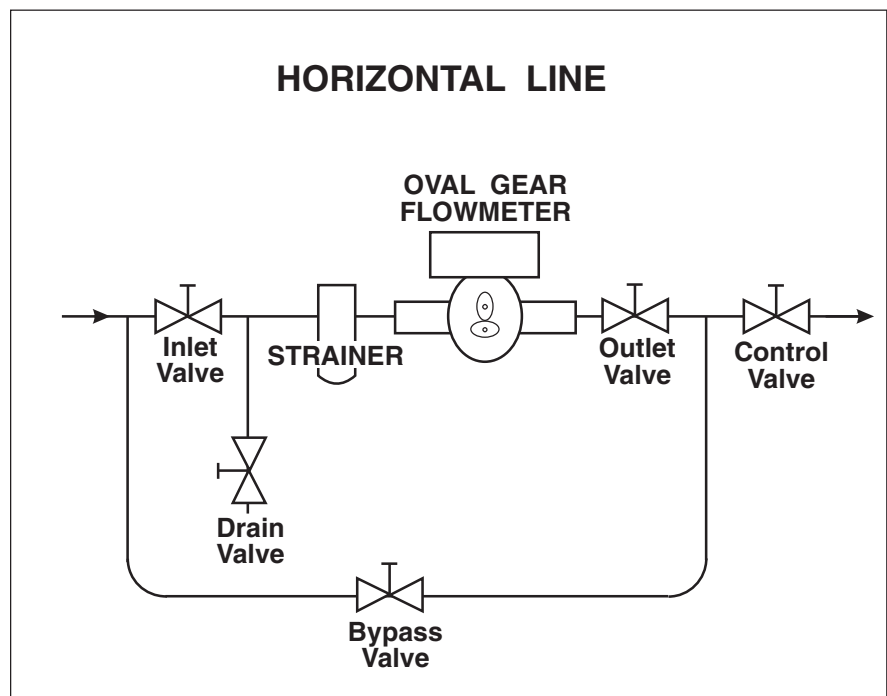

Figures 2-5 Horizontal Installation.

BM Oval Series

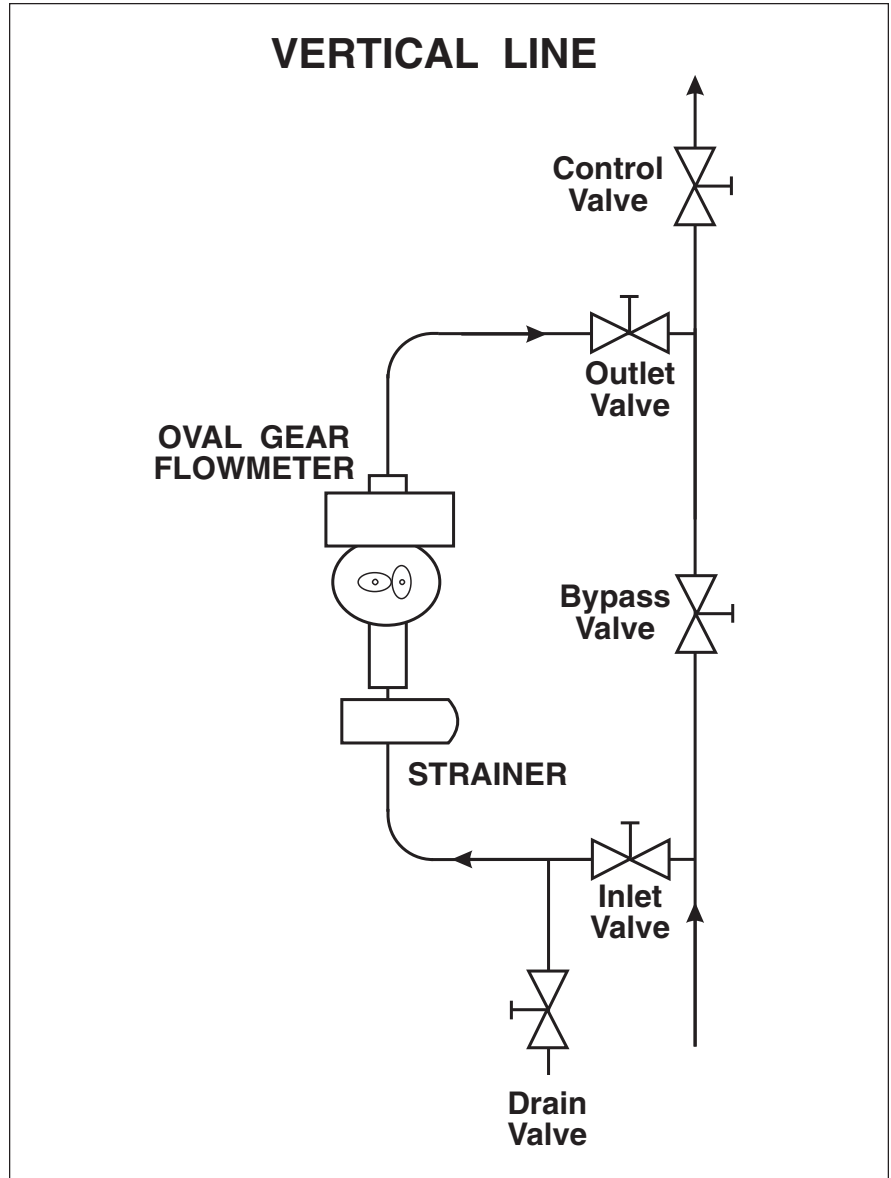

Figures 2-6 Vertical Installation.

### 3-1 General

The flowmeter has been completely assembled, checked and calibrated at the factory. Therefore, no adjustments are required for installation.

### 3-2 Flowmeter Principle of Operation (See Figure 3-1)

The Oval Flowmeter accurately measures liquid flow by using a slight pressure differential to rotate a pair of oval gears. The meshed gears seal the inlet from the outlet flow, developing the pressure differential. When in the position as shown in Figure 3-1A, Gear A receives torque from the pressure difference, the torque upon Gear B cancel one another, and Gear A drives Gear B as depicted in Figure 3-1B. When Gear A rotates to the position as shown in Figure 3-1C, it loses torque, but Gear B obtains torque and drives Gear A. This alternate driving action provides a smooth rotation of almost constant torque without dead spots. Figures 3-1D, 3-1E, 3-1F, 3-1G, 3-1H, and 3-1J illustrate this principle through a complete cycle bringing Gear A back to its original position as shown in Figure 3-1A. During rotor rotation, the rotors trap precise quantities of liquid in the crescent shaped gaps or measuring chambers. Total quantity of flow for one complete cycle of the rotors is four times that of the crescent shaped gap. Rate of flow is proportional to the rotation speed of the rotors. Because the amount of slippage between the rotors and the measurement chamber wall is minimal, the flowmeter is essentially unaffected by changes in viscosity and lubricity of the liquid.

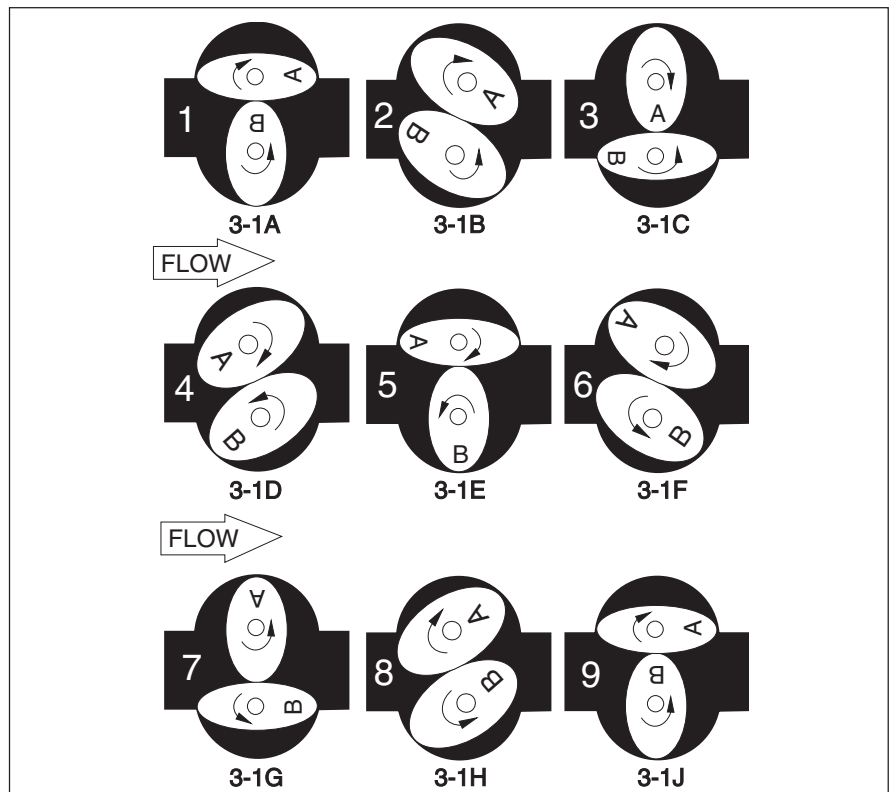

Figure 3-1 Principle of Operation.

## BM Oval Series

**3-3 Pulse Generator Principle of Operation (See Figure 3-1)****Pulse Generator:**

When fluid passes through the meter, rotors turn. The magnets which are located in the rotors will pass across the pulser circuit board (containing either Reed Switches or Hall Effect sensors). A signal is received which is then sent by the Pulse Circuit Board (PCB) to the relevant LC display or receiving instrument.

**Mechanical Display:**

When fluid passes through the meter rotors turn. The gear located on top of one of the rotors drives the mechanical registers gear train which provides an accurate readout.

**3-4 Operating Instructions**

At initial operation, carefully operate in the following sequence, allowing the flow within the flow range specified. (Refer to Figures 2-3 and 2-4).

1. Shut off the valve (A) on the inlet side and the valve (B) on the outlet side and then open the bypass line valve (C) to allow the fluid in the bypass line, thereby removing weld chips, scales and other foreign matter left in the piping assembly.

**NOTE:** This is particularly important on new installations.

2. Carefully and slightly at first, open the valve (A) upstream of the meter progressively and then, slightly at first, open the valve (B) downstream progressively.
3. Slowly close the bypass line valve (C) and make sure that the total counter in the receiving instrument advances in response. Maintain a flowrate 10 to 20% of the maximum flowrate at this time, allow the flow for more than 15 minutes and make sure that air in the piping assembly has totally escaped.

**NOTE:** In applications where temperatures exceed 60°C (140°F), run the system at least for 30 minutes in this state to ensure uniform heat distribution in the measuring chamber.

4. Following the break-in operation (preheating), shut off the bypass line valve (C) completely. Open the upstream valve (A) progressively until fully open then slowly open the downstream valve (B) until the rated flow is reached.
5. Flowrate should be regulated with the downstream valve (B) and should be held within the rating.
6. The strainer should be inspected for condition and cleaned on a regular basis.

**⚠ CAUTION**

**Use extra care not to overspeed the meter or the rotors in the measuring chamber could be damaged.**

### 3-5 Operating Precautions

Periodic inspections should be made during flowmeter operation. The following points should be checked and the flowmeter shut down if any discrepancy is found.

1. When changing flowrates

In applications where the flowrate varies or where shut-off valve opening and closure takes place in batch operation, avoid rapid changes in flowrate across the meter. Operating the meter at flowrates in excess of the maximum allowable flowrate will nullify the guaranteed accuracy, reduce the meter life and may result in faulty conditions, such as seizure of bearings or rotor-to-measuring chamber contact.

2. Where the temperature of metered fluid changes

Avoid rapid temperature changes in the meter. Temperature changes of the fluid in the meter should be held within 3°C, 37°F per minute.

Extra care should be used particularly when making a flow measurement in batch operation without the provision of heat tracing of the piping where the fluid temperature differs from atmospheric temperature.

**NOTE: If rapid temperature changes are anticipated, heat trace the piping assembly as well as the meter.**

3. Liquids of low steam pressure

Liquids with low viscosity and low steam pressure are prone to vaporize and their temperature and pressure should, therefore, be strictly controlled. During operation, the temperature of bearings in the meter is usually higher than that of the metered fluid. Vapors around the bearings can be causes of faulty conditions, including generation of unusual noise and bearing seizure.

4. Corrosive liquids

When you make a measurement of highly corrosive liquids, appropriate materials should be used for tanks and piping assembly.

Heterogeneous materials originally contained in the metered fluid or corrosive substances liquated out from tanks and pipes of inappropriate materials may lock the rotors in the measuring chamber and lead to costly downtime.

### 3-6 Precautions at Operation Shutdown

1. Valves should be closed progressively.

Rapid valve closure could, under certain piping conditions, cause a sharp pressure rise by water hammer, or hydraulic shock, resulting in damage to the meter.

2. Precautions against pressure buildup on closure.

Complete closure of valves upstream and downstream of the meter produces a totally enclosed space between the valves. A pressure buildup relative to a rise in atmospheric temperature could lead to damage to the meter.

## BM Oval Series

## 3. Liquids that readily adhere or gel.

Liquids that tend to adhere and solidify or gel at flow velocities around zero must thoroughly be washed away from the meter interior with running cleaning fluid before shutdown. Negligence of this precaution could produce an immovable mass of components when the operator attempts to resume meter operation.

**NOTE:** Turn pump off at end of each day.

## 3-7 Operation of Standard LC Display

Following keys are available:

Functions of the keys:

(Refer to Figures 3-2a & 3-2b)

**Prog / Enter** : This key has no function at operator level. It is used only to configure the unit; please read Section 3.

**Select /s** : This key is used to SELECT accumulated total\*.

The arrow-key (s)

is only used to configure the unit; please read Section 3.

**Clear/ u** : Press this key twice to CLEAR the actual value for Total.

The arrow-key (u) is only used to configure the unit; please read Section 3.

\* This can vary due to SETUP changes.

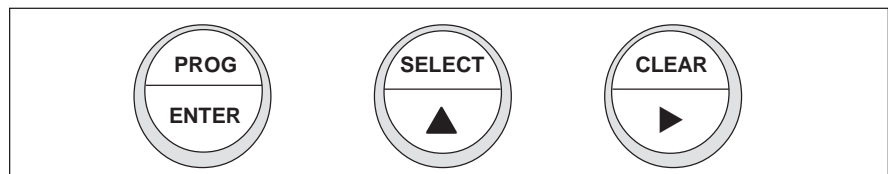

Figure 3-2a Control Panel



Figure 3-2b BM10 Standard LCD Display

**Brief Description of the Standard Display**

The Standard display is a microprocessor driven instrument designed to display flowrate, Total and accumulated Total. The Standard Display is designed to be implemented in many types of applications. For that reason, a SETUP-level is available to configure your Standard Display according to your specific requirements. SETUP includes several important features as

K-factors, measurement units. To extend the battery-life time, please make use of the power-management functions.

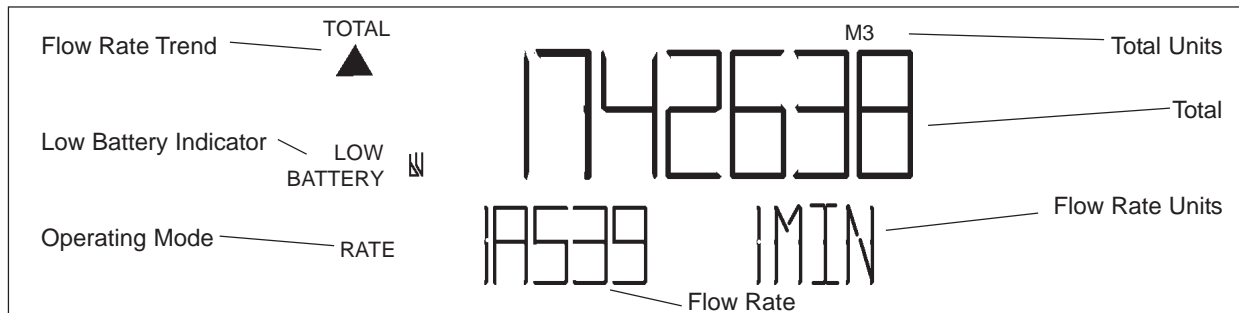

Figure 3-2c Control Panel Display

This section describes the daily use of the Standard Display. This instruction is meant for the users and operators. (Refer to Figure 3-2c)

In general, the Standard Display will always act at Operator level. The information displayed is dependant on the SETUP-settings. Although the refresh-rate of the display might be slow (due to power-management functions), each flowmeter pulse will be measured. After pressing a key, the display will be updated very fast for 30 seconds after which it will slow-down again.

For the Operator, following functions are available:

**Display Rate/Total or Rate:**

This is the main display information of the Standard Display. After selecting other information, it will return to the main display automatically. The actual flowrate is either displayed at the bottom line or with the 17mm digits at the upper line. When "-----" are shown, the flowrate value is too high to be displayed. The arrows indicate the increase/decrease of the flowrate trend.

**Clear Total:**

The value for Total can be cleared. To do so, press CLEAR, after pressing CLEAR, the text "PUSH CLEAR" is displayed. To avoid clearing at this stage, press a different key or wait for 10 seconds. Clearing Total DOES NOT influence accumulated Total.

**Display Accumulated Total:**

When the SELECT-key is pressed, Total and Accumulated Total are displayed. Accumulated Total can never be initialised. To return to the main display press Select or Prog/Enter, or leave for 10 seconds and the display will return automatically.

**Low-battery Alarm:**

When the battery voltage drops, it must be replaced. At first "low-battery" will flash, but as soon as it is displayed continuously, the battery MUST be replaced shortly after! Only official batteries may be used, or else the guarantee will be terminated. The remaining lifetime after the first moment of indication is generally several days up to some weeks. Allow sufficient lead time for Battery delivery.

BM Oval Series

**Alarm 01 - 03:**

When Alarm is displayed, please consult Section 4 for Problem solving.

**Programming Setup-Level:**

Configuration of the Standard Display is done at SETUP-level. SETUP-level can be reached by pressing the PROG/ENTER key for 7 seconds; at which time, both arrows will be displayed. In order to return to the operator level, PROG will have to be pressed for three seconds. Alternatively, if no keys are pressed for 2 minutes, the unit will exit SETUP automatically. SETUP can be reached at all times and the Standard Display remains full operational.

**Password:** A password may be required to enter SETUP. Without this password access to SETUP is denied.

SETUP is divided into several main- and sub-functions. Main functions are selected with (u) and sub-functions with (p). Each function has a unique number, which is displayed below the word "SETUP" at the bottom of the display. The number is a combination of two figures. The first figure indicates the main-function and the second figure the sub-function: For example 12 is main-function 1 and sub function 2. Furthermore, each function is expressed with a keyword. After selecting a sub-function, the next main function can be selected after scrolling through all "active" sub-functions (like 1▲, 11▲, 12▲, 13▲, 14▲, 1▶, 2▶, 3▲, 31▶ etc.).

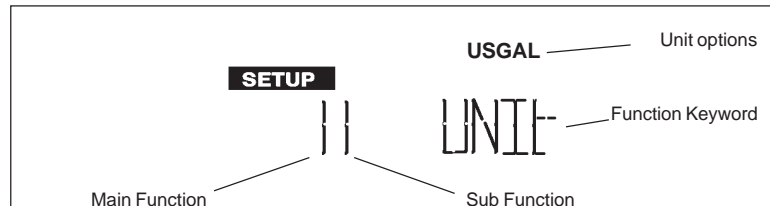

Figure 3-3 Control Panel Display, Example of Function

**SETUP has been divided as follows:**

	14	Decimals K-factor: 0 - 6
	13	K-factor: 0.000010 - 9,999,999
	12	Decimals: 0 - 1 - 2 -3
← Total	11	Unit: L - m3 - kg - lb - GAL - USGAL - bbl - no unit
1 ↓	27	Cut-off: 0.1 - 999.9 seconds
	26	Calculation: per 1 - 255 pulses
	25	Decimals K-factor: 0 - 6
	24	K-factor: 0.000010 - 9,999,999
	23	Decimals: 0 - 1 - 2 - 3(Ref: Display value)
	22	Time Unit: sec - min - hour - day
← Flowrate	21	Unit: mL - L - m3 - mg - g - kg - ton - GAL - bbl - lb - cf - rev - no unit
2 ↓	31	Function: total - flowrate
← Display	42	Battery Mode: operation - shelf
3 ↓	41	LCD Update: fast - 1sec - 3sec -15sec - 30sec - off
← Power Management	51	Signal: NPN - NPN_LP - Reed - Reed_LP
4 ↓	65	Tag number: 0000000 - 9999999
← Flowmeter	64	Password: 0000 - 9999
5 ↓	63	Serial No:
← Others	62	Software Version:
6 ↓	61	Type/Model:

### Programming Procedure

The Programming procedure (PROG) is applicable for programming, selecting or deleting values on SETUP-level. The procedure is executed as follows:

- 1) Enter the desired SETUP sublevel as detailed in Section 3.2.1
- 2) Press PROG briefly,
- 3) Enter a value or make a selection with the pu keys.
- 4) Set the operation by pressing ENTER.

To change a value, use u to select the digits and p to increase that value. To select a setting, both ▲ and ► can be used. When the new value is not valid, the increase sign ▲ or decrease-sign ▼ will be displayed while you are programming. When data is altered but ENTER is not pressed, then the alteration can still be cancelled by waiting for 20 seconds or by pressing enter for 3 seconds: the PROG-procedure will be left automatically and the former value reinstated.

#### **TOTAL; MEASUREMENT UNIT - SETUP LEVEL 11:**

SETUP - 11 determines the measurement unit for TOTAL and accumulated Total. The following units can be selected:

L - m<sup>3</sup> - kg - lb. - GAL - USGAL - bbl - \_ (no unit).

Alterations of the measurement unit will have consequences for operator and SETUP-level values. Please note that the K-factor has to be adapted as well (the calculation is not done automatically).

#### **TOTAL; NUMBER OF DECIMALS DISPLAYED - SETUP LEVEL 12:**

The decimal point determines for Total and accumulated Total the number of digits following the decimal point. The following can be selected:

0000 - 111.1 - 22.22 - 3.333

#### **TOTAL; K-FACTOR - SETUP LEVEL 13:**

With the K-factor, the flowmeter pulse signals are converted to a quantity. The K-factor is determined on the basis of the measurement unit and the number of pulses generated per measurement unit by the flowmeter. Enter the number of pulses generated by the flowmeter per selected measurement unit (e.g per litre). The more accurate the K-factor, the more accurate the functioning of the system will be. Example 1: Calculating the K-factor.

Let us assume that the flowmeter generates 2.4813 pulses per litre and the selected unit is "cubic metres / m<sup>3</sup>". A cubic metre consists of 1000 parts of one litre which implies 2,481.3 pulses per m<sup>3</sup>. So, the K-factor is 2,481.3. Enter for SETUP - 13: "2481300" and for SETUP - 14 - decimals K-factor "3".

#### **Example 2: Calculating the K-factor.**

Let us assume that the flowmeter generates 6.5231 pulses per gallon and the selected measurement unit is gallons. So, the K-Factor is 6.5231. Enter for SETUP - 13: "6523100" and for SETUP - 14 decimals K-factor "6".

#### **TOTAL; NUMBER OF DECIMALS FOR K-FACTOR TOTAL - SETUP LEVEL 14:**

This function determines the number of decimals for the K-factor (SETUP13). The following can be selected:

0 - 1 - 2 - 3 - 4 - 5 - 6

Please note that this function influences the accuracy of the K-factor indirectly. This setting has NO influence on the displayed number of digits for Total (SETUP 12).

## BM Oval Series

**Flowrate - 2**

The settings for Total and flowrate are entirely separated. In this way, different measurement units can be used like cubic meters for Total and litres for flowrate.

**FLOWRATE; MEASUREMENT UNIT - SETUP LEVEL 21:**

Setup - 21 determines the measurement unit for flowrate.

The following units can be selected:

mL - L - m<sup>3</sup> - mg - g - kg - ton - GAL - bbl - lb. - cf - rnd(rnd for RPM)\_ (no unit).

Alterations of the measurement unit will have consequences for operator and SETUP-level values. Please note that the K-factor has to be adapted as well (the calculation is not done automatically).

**FLOWRATE; TIME UNIT - SETUP LEVEL 22:**

The actual flowrate can be calculated per second (SEC), minute (MIN), hour (HR) and day (DAY).

**FLOWRATE; NUMBER OF DECIMALS DISPLAYED - SETUP LEVEL 23:**

This setting determines for Flowrate the number of digits following the decimal point. The following can be selected:

00000 - 1111.1 - 2222.22 - 3333.333

**FLOWRATE; K-FACTOR - SETUP LEVEL 24:**

The K-factor is used to calculate a volumetric quantity based on the number of pulses based on the number of pulses received within a specified time period. This K factor is determined on the basis of the measurement unit and the pulses generated per measurement unit by the flow meter. Enter the number of pulses generated by the flowmeter per selected measurement unit (e.g. per Litre). The more accurate the K-factor, the more accurate the functioning of the system will be. For examples see SETUP 13.

**FLOWRATE; NUMBER OF DECIMALS K-FACTOR - SETUP LEVEL 25:**

This function determines the number of decimals for the K-factor (SETUP 24).

The following can be selected:

0 - 1 - 2 - 3 - 4 - 5 - 6

Please note that this SETUP - influences the accuracy of the K-factor indirectly. This setting has NO influence on the displayed number of digits for "flowrate" (SETUP 23).

**FLOWRATE; CALCULATION - SETUP LEVEL 26:**

The flowrate is calculated by measuring the time between pulses. As several types of flowmeters have an unequal pulse-train, it is advised to calculate the flowrate over several pulses, for example 10 pulses; the maximum value is 255 pulses. Please understand that the calculation time for very low frequencies (0.1-5 Hz) is influenced by this setting as well; so do not program too many pulses! When the frequency is above 3 kHz during normal conditions, it is advised to calculate over 50 or more pulses.

**FLOWRATE; CUT-OFF TIME - SETUP LEVEL 27:**

With this setting, you determine a minimum flow requirement threshold, if during this time less than XX-pulses (SETUP 26) are generated, the flowrate will be displayed as zero. Time in seconds.

**Display - 3****DISPLAY; FUNCTION - SETUP LEVEL 31:**

The large 17mm digits can be set to display Total or flowrate digits at operator-level. When Total is selected, both Total and flowrate are displayed simultaneously. When flowrate is selected, Total will only be displayed after pressing select.

**Power Management - 4**

As the Standard Display is normally battery powered, the user will have the concern of reliable measurement over a long period of time. The Standard Display has several smart power management functions to extend the battery life time significantly. Two of these functions can be set:

**POWER MANAGEMENT; LCD UPDATE - SETUP LEVEL 41:**

The calculation of the display-up-date time influences the power consumption significantly. When the application does not require a fast display update, we advise you to select a slow refresh-rate. Please understand that NO information will be lost; every pulse will be counted and the output-signals are not influenced. The following can be selected: Fast - 1 sec - 3 sec - 15 sec - 30 sec - off.

Please note that - after a button is pressed by the operator - the display refresh-rate will be FAST during the initial 30 seconds period. When off is selected, the display will be switched off after 30 seconds and will be switched on again as soon as any button has been pressed. Power Management; Battery Mode - 42:

The unit has two modes: operational or shelf. When shelf is selected, you can store the unit for several years; it will not count pulses, the display is switched off but all setting are stored. In this mode, power consumption is extremely low. Normally, the mode will be operational.

**Flowmeter - 5**

**FLOWMETER; SIGNAL - SETUP LEVEL 51:**

The Standard Display is able to handle several types of signals. The type of flowmeter pickup / signal is selected in software with SETUP 51.

Table 3-1 Setup

Type of Signal	Explanation	Resistance	Power Consumption	Max. Freq.	Remarks
NPN	Standard NPN input	100K pull-up	Relative high	7KHz	(open collector)
NPN - LP	NPN with low pass filter	100K pull-up	Relative high	1.2KHz	(open collector) less sensitive
REED	Reed-switch input	1M pull-up	Low	800Hz	
REED - LP	Reed-switch + low pass filter	1M pull-up	Low	120Hz	Less sensitive

**Note: NPN (Hall Effect Sensors) requires an external power supply, contact your local distributor if you are considering using these style of sensor. To maximize battery life it is recommended that Reed\_lp be used.**

**OTHERS; TYPE OF MODEL - SETUP LEVEL 61:**

For support and maintenance it is important to have information about the characteristics of the Standard Display. Your supplier will ask for this information in the case of a serious breakdown or to assess the suitability of your model for upgrade considerations.

**OTHERS; VERSION OF SOFTWARE - SETUP LEVEL 62:**

For support and maintenance it is important to have information about the characteristics of the Standard Display. Your supplier will ask for this information in the case of a serious breakdown or to assess the suitability of your model for upgrade considerations.

## BM Oval Series

**OTHERS; SERIAL NUMBER - SETUP LEVEL 63:**

For support and maintenance it is important to have information about the characteristics of the Standard Display. Your supplier will ask for this information in the case of a serious breakdown or to assess the suitability of your model for upgrade considerations.

**OTHERS; PASSWORD - SETUP LEVEL 64:**

All SETUP-values can be password protected. This protection is disabled with value 0000 (zero). Up to and including 4 digits can be programmed, e.g. 1234.

**OTHERS; TAG NUMBER - SETUP LEVEL 65:**

For identification of the unit and communication purposes, a unique tag number of maximum 7 digits can be entered.

- This unit must be installed in accordance with the EMC guidelines (Electro Magnetic Compatibility).
- Electro static discharge does inflict irreparable damage to electronics! The electrician has to discharge himself by touching a well-grounded object before opening the casing.
- NEVER expose the Standard Display to strongly varying (weather) conditions.
- When used in very cold surroundings or heavy varying temperatures, take the necessary precautions against moisture by placing a dry sachet of silica gel inside the display housing.

**Installation****Voltage Supply Flowmeter Pick-up**

Externally Powered Applications 8.30 Vdc:

When the Standard Display is externally powered, the sensor can be powered with the same voltage by using the shared terminal 4. If the unit is fitted with a battery as well, the output voltage of 3.2 Vdc from the battery is blocked automatically as soon as you connect the external power-supply.

**Battery Powered Applications:**

A supply voltage of 3.2 Vdc is available for the signal output of the flowmeter. **This voltage MAY NOT be used to power the flowmeters electronics, converters etc.** as it is not a power supply as such! All energy used by the flowmeters pick-up influences the battery life directly; it is strongly advised to use a "zero power" pickup with the battery option, such as a reed-switch. It is possible to use a low power input NPN output signal, but the battery life time will be reduced.

**Terminal Connectors**

The following terminal connectors are available:

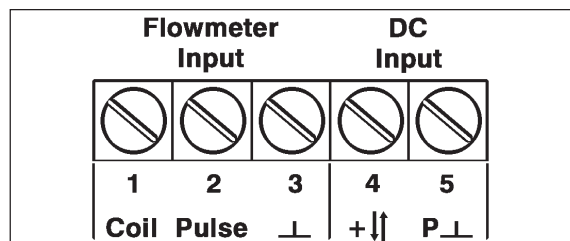

Figure 3-4 Terminal Connectors

**Remarks Terminal Connectors:**

Terminal 1-3; Flowmeter Inputs

The pulse has to be connected to terminal 2. The screen of the signal wire must be connected to terminal 3 (GND). The voltage supply (3.2 Vdc) to the flowmeter should be connected to terminal 4. Please read par. 4.2. for power supply flowmeter. The maximum input frequency is approximately 7 kHz (depending on the type of signal see Section 3.2.3.5).

**Pulse-signal NPN/PNP:**

The Standard Display is suitable for flowmeters which have a pulse output that is equal or almost equal to the supply voltage (3.2 Vdc). For a reliable detection, the pulse amplitude has to cross 1.2 Vdc once per cycle.

Transducers which generate a higher amplitude than 3.2 Vdc can be used but the detection level is still 1.2 Vdc. Maximum voltage input is rated for pulse amplitudes of 24 Vdc.

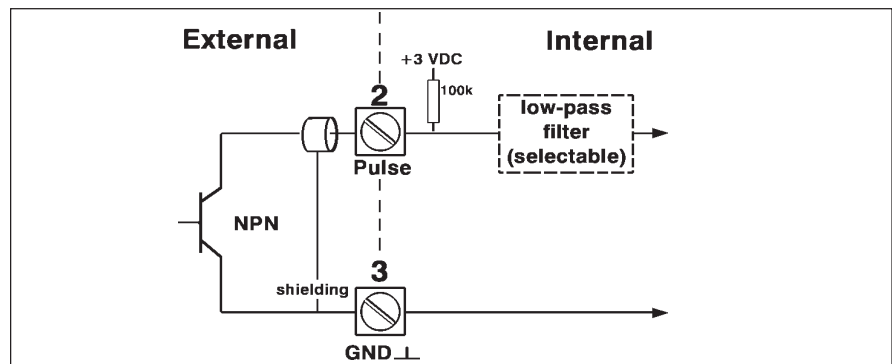

Figure 3-5 Pulse-Signal NPN/PNP

Reed-switch:

The Standard Display is suitable for flowmeters which have a reed-switch. To avoid pulse bounce from the reed-switch, it is advised to select REED LP - low-pass filter (setting 51).

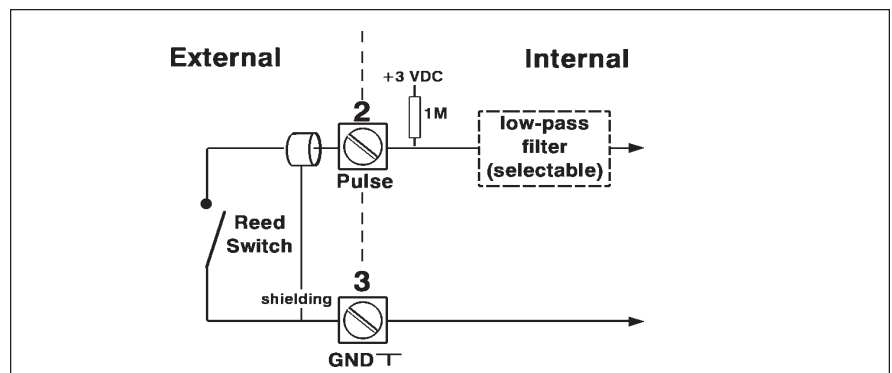

Figure 3-6 Reed-Switch

Terminal 4 and 5; external power supply 8-30 Vdc:

Connect an external power-supply of maximum 30 Vdc to these terminals. Connect the “-” to terminal 5 and the “+” to terminal 4. The output voltage from the battery (option) is blocked automatically as soon as a higher input voltage than 3.2 Vdc is connected: it won’t damage the battery.

**3-8 Deluxe LCD Display Description**

---

**Normal Operation**

The quantity of liquid passing through the meter will be measured and displayed (partial quantity counter). No additional devices are required.

**Automatic Operation (Presettable Batch Controller)**

A preset quantity can be transferred in automatic operation. In order to control valves, the motor of the pump and/or other similar devices by the meter, an amplifier according to NAMUR signals is required. The amplifier transforms the control signal from the meter into relay signals.

**For transferring foaming liquids or if shock pressures are too high;**

The meter enables a measuring operation of a liquid in three steps. For this it is necessary to use two valves.

**Step 1:** Both valves are open

**Step 2:** One valve closes (precise measuring operations starts).

**Step 3:** The second valve closes

1 amplifier with 2 output signals, 2 valves and a regulating valve are required.

**Leakage Quantity (Time lag of valves)**

If the "OFF" signal (close) is displayed, there will be a time lag before the valve will be closed. During this time an unknown quantity of liquid will pass through the meter. This quantity is called leakage quantity. The leakage quantity is measured by the meter during each measuring operation and it is taken into account when starting the next measuring operation.

**Note:** The current leakage quantity always depends on the previous measuring operation.

**Factory Calibration**

Factory calibration is not protected and can be changed by the user. Calibration constant is entered prior to shipment.

**Presignal Quantity:**

The set presignal quantity is valid for all preset quantities.

The presignal quantity can be set between 0.0 and 9.9 Liters/Gallons. (Relative Automatic Operation)

**Cycle Counter:**

No overflow indication (the counter starts again at zero).

If the preset quantity is changed, this counter will reset to zero automatically

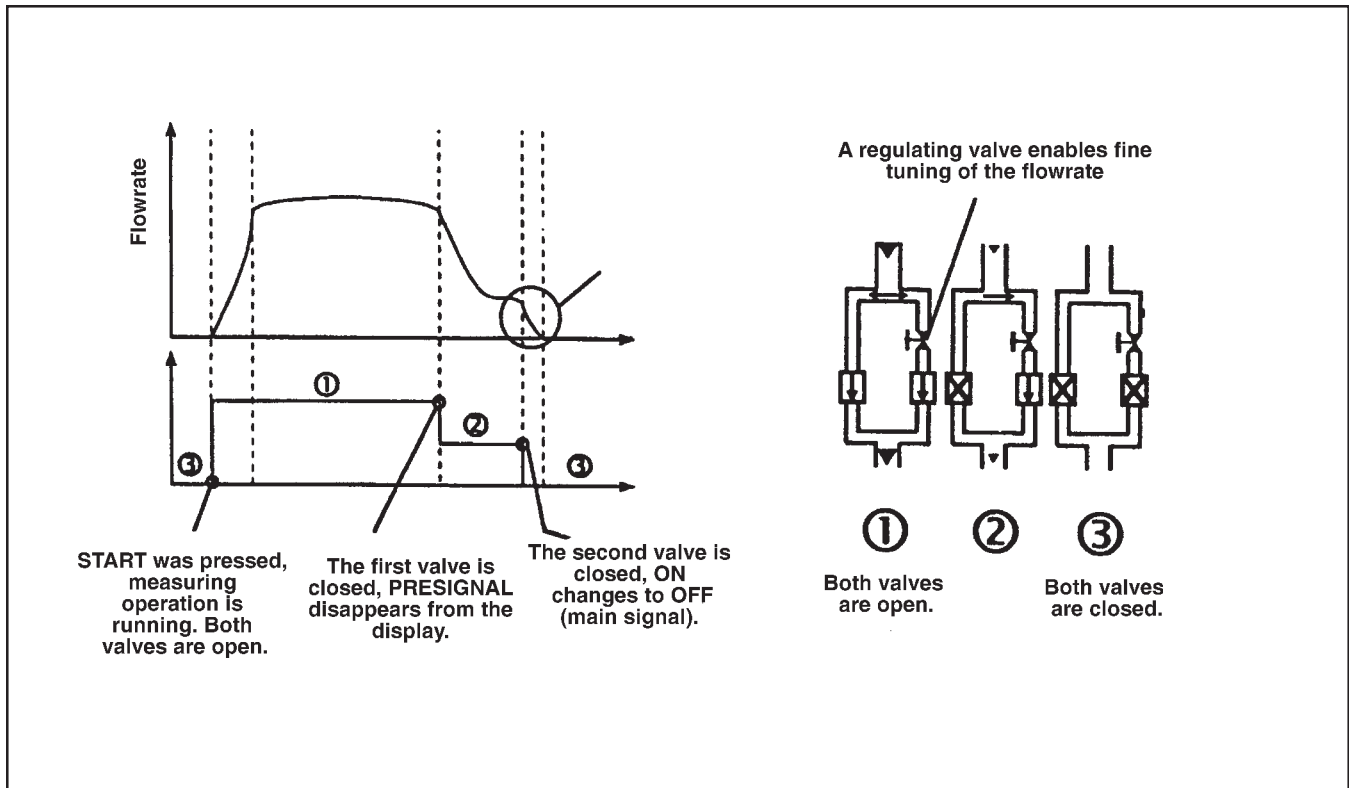

Figure 3-7 Batch Control Diagram

Table 3-2 Calibration Settings by Model Number

Model	Calibration
<b>BM04</b>	<b>0089</b>
<b>BM07</b>	<b>0192</b>
<b>BM10</b>	<b>0278</b>
<b>BM40</b>	<b>0689</b>
<b>BM50</b>	<b>1500</b>

## BM Oval Series

## 3-9 Deluxe LCD Specifications



Figure 3-8 Deluxe LCD

**The Deluxe Liquid Crystal Display****Measuring Unit:**

Can be set to Liters, US Gallons, or Imperial Gallons.

Imperial Gallons = "IMP GAL" = 4.5460 Liters

US Gallons = "US GAL" = 3.7854 Liters

**Calibration Constant:**

10 different constants can be recorded.

Each constant can be set by keys within the range of 0.0000 to 0.99999.

Only the 4 points after the decimal point are displayed.

**Partial Quantity Counter:**

7-Digit Display; 999999.9 Liters Maximum

999999.9 Gallons Maximum

No overflow indication (the counter starts again at zero).

Resettable to zero by special combination of keys only.

**Totaliser:**

7-Digit Display without decimal point;

9999999 Liters Maximum.

9999999 US Gallons Maximum.

**Automatic Range Presetting:**

To be set to 99.99, 999.9 or 9999 Liters/Gallons.

(Relative Automatic Operation)

**Preset Quantity:**

10 different preset quantities can be set.

The preset quantity can be within the predetermined range

(Automatic range of presetting).

(Relative Automatic Operation)

If the preset quantity is changed, this counter will reset to zero automatically.

3-10 Deluxe LCD Operation

Meter Keys Overview

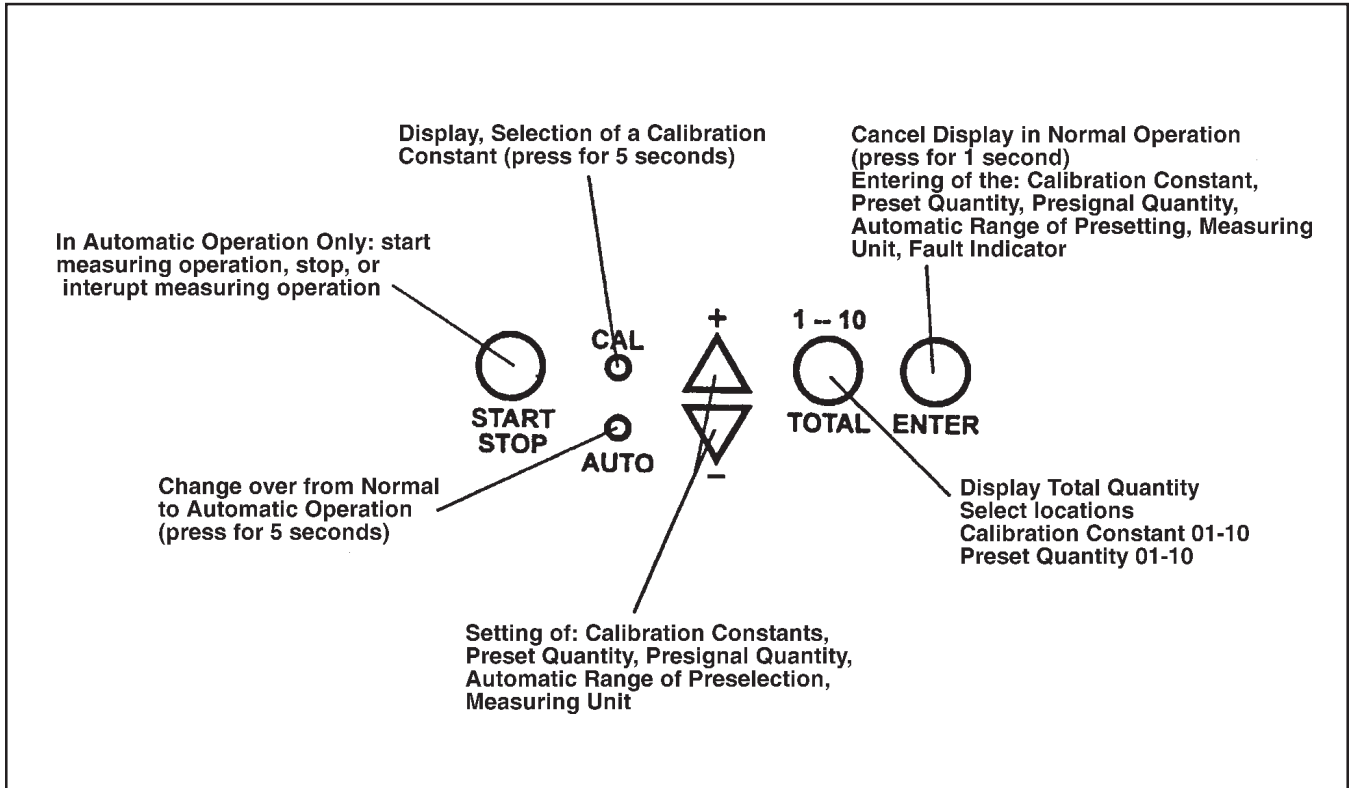

Figure 3-9 Locations and Functions of Meter Keys

BM Oval Series

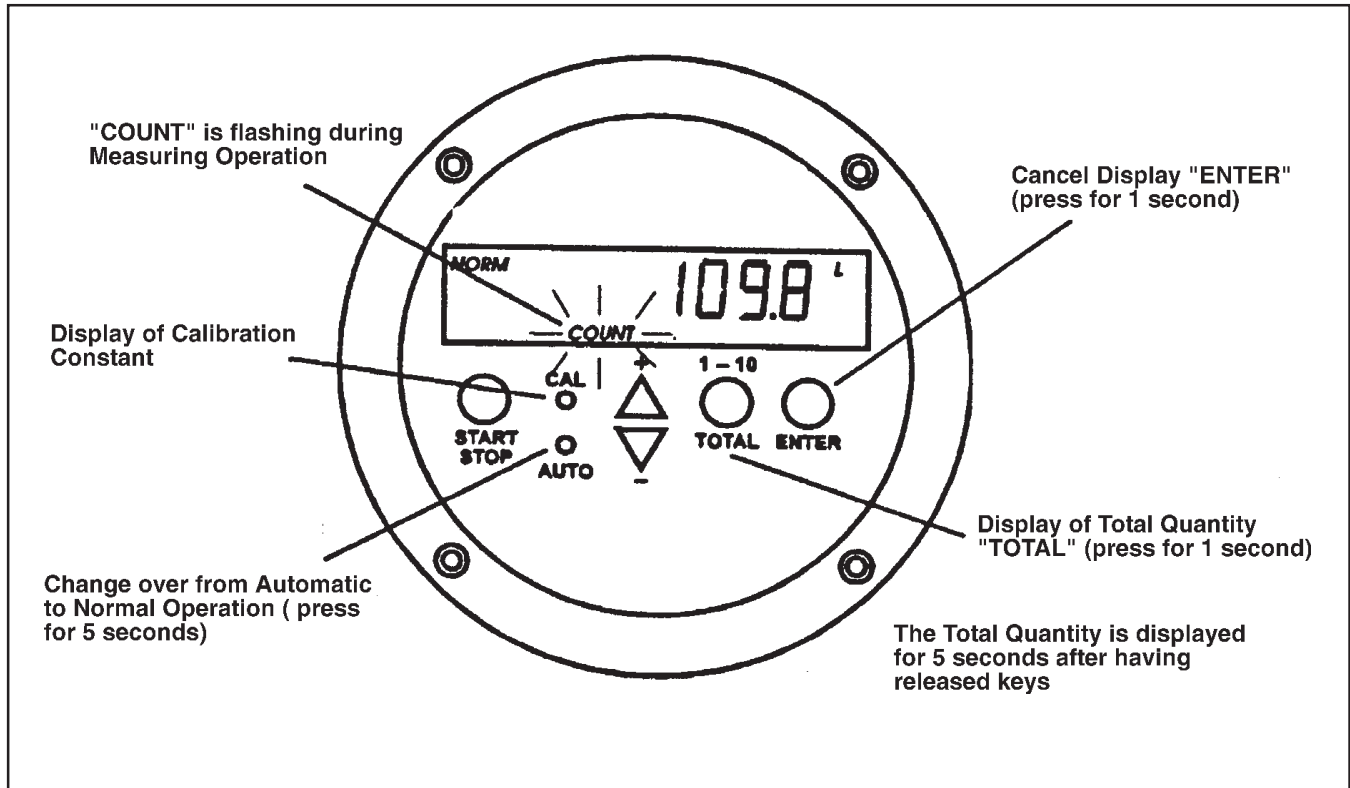

Figure 3-10 Operation View (Normal Mode)

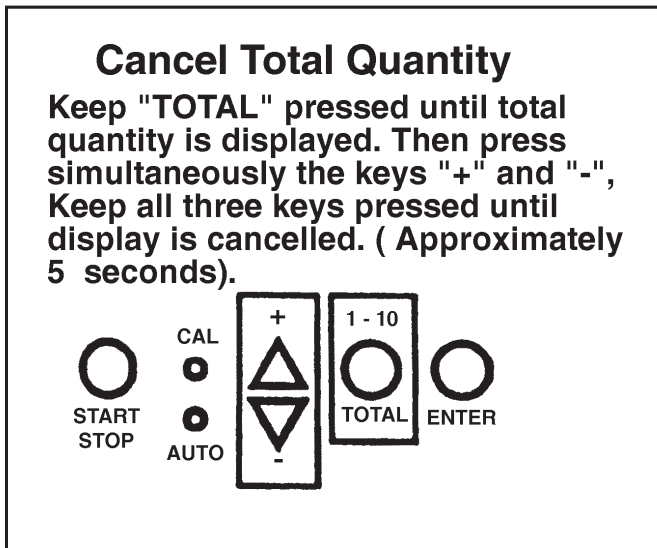

Figure 3-11 Cancel Total Quantity (Normal Mode)

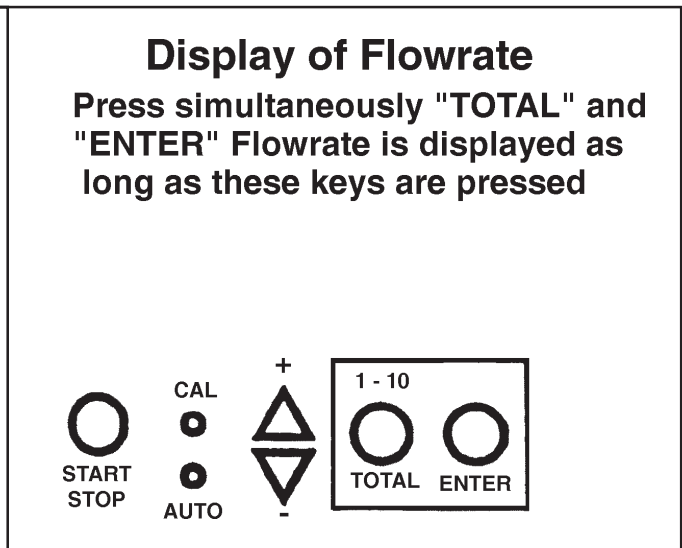

Figure 3-12 Display of Flowrate (Normal Mode)

**Normal Operation Mode:**

To perform the following procedures in normal operation mode (Refer to Figure 3-10).

**Cancel Total Quantity** (Figure 3-11)

**Display Flowrate** (Figure 3-12)

**Automatic Operation Mode:**

Display is flashing; change respective setting by "+"; "-" or "1-10".  
 The setting will be confirmed by pressing "ENTER".

To perform the following procedures in automatic mode:  
 (Refer to Figure 3-12).

Cancel Total Quantity (only possible in normal operation mode)

Display Flowrate (Figure 3-12)

**Fill Quantity Operation**

Press Auto button and hold for 5 seconds to enter automatic mode.  
 (See Figure 3-13)

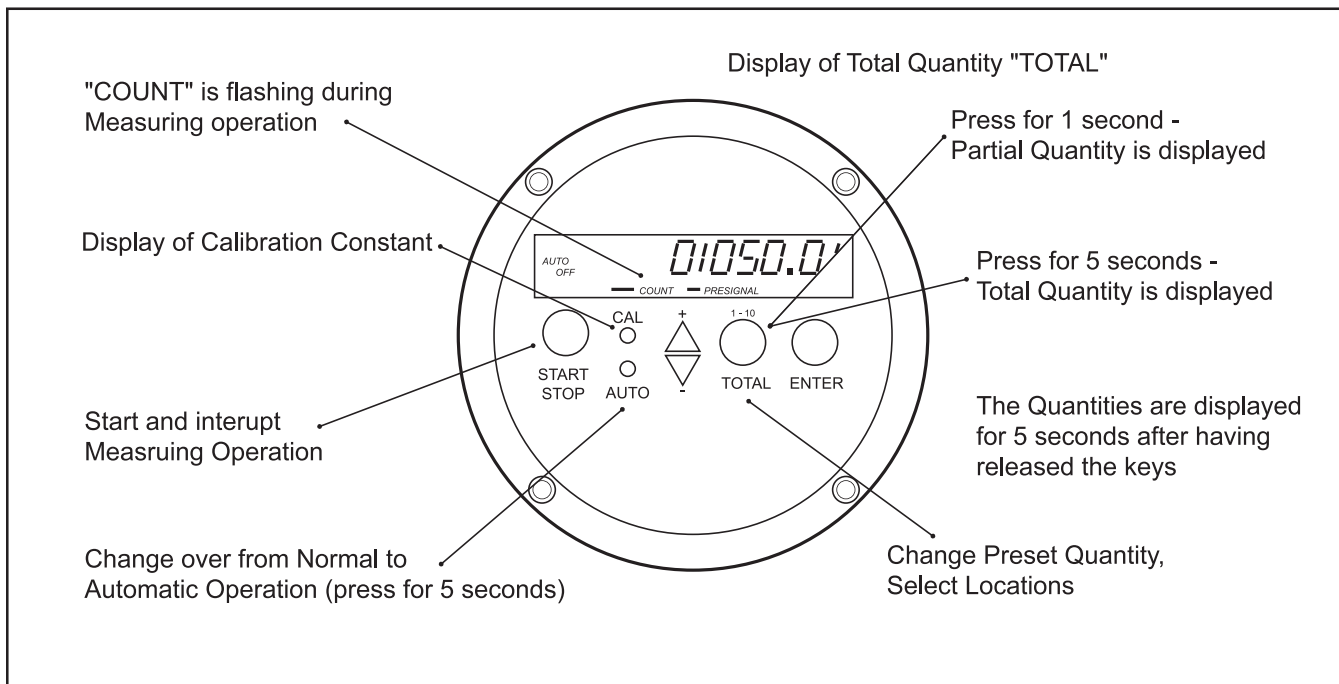

Figure 3-13 Operation View (Automatic Mode)

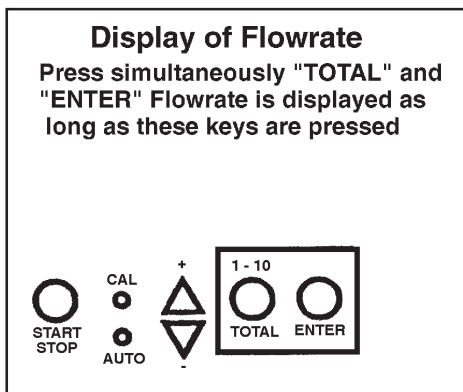

Figure 3-14 Display of Flowrate (Automatic Mode)

BM Oval Series

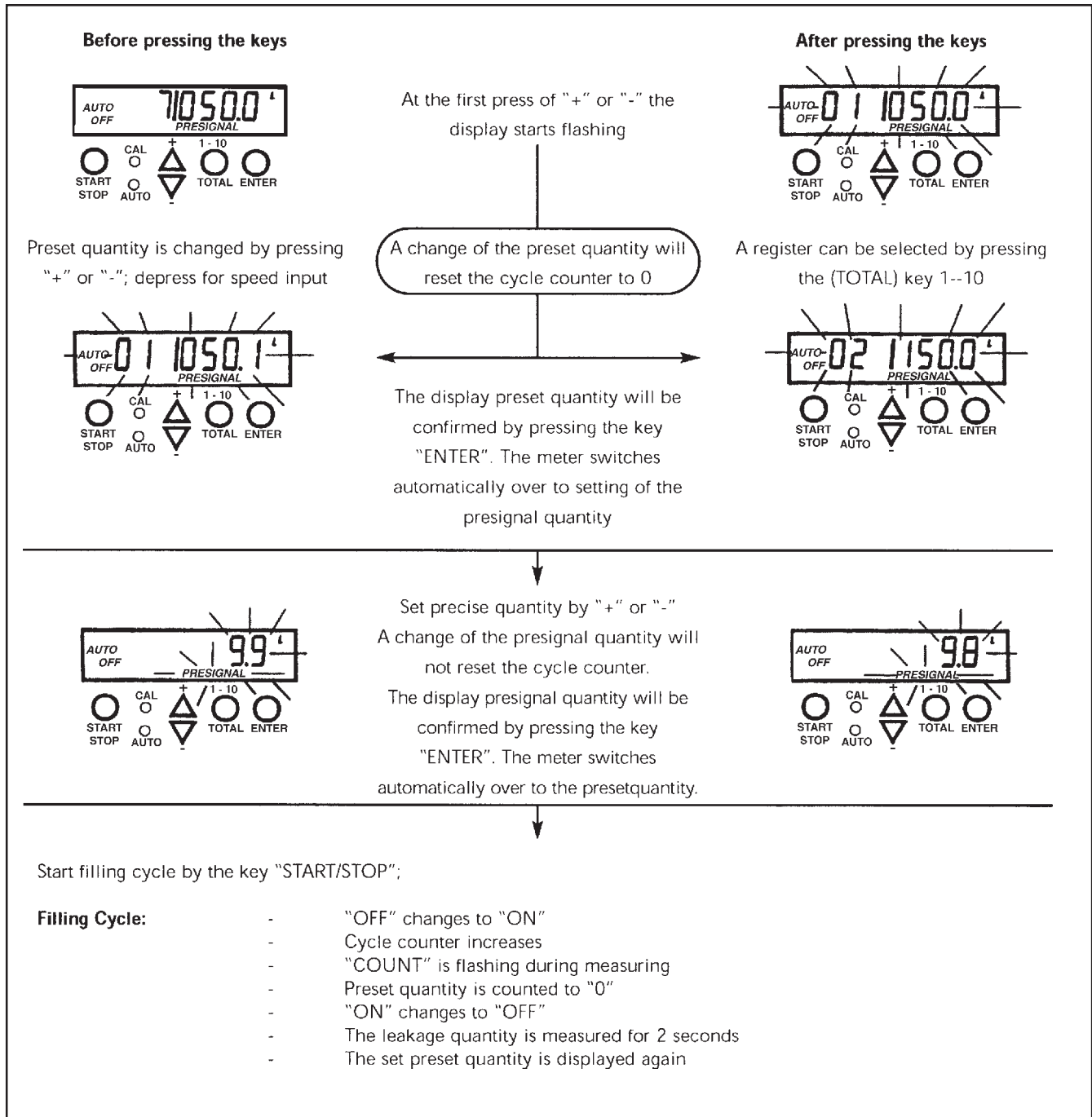

Figure 3-15 Operation View (Automatic Mode)

Table 3-3 Fault Indicator

Fault indicator is flashing ! "FFFF" Press the key "ENTER"	
FAULT	CLEAR FAULT
The presignal quantity plus the automatically measured leakage quantity are higher than the total filling quality	Increase total filling quantity or reduce presignal quantity or use the higher speed valves (reduce leakage quantity)
Fault indicator is static! "FFFF"	Press the key "ENTER" - remaining filling quantity is displayed  Continue measuring operation of the remaining filling quantity by pressing the key "START/STOP"  Press again "ENTER" - back to the preselection quantity
No flow has been for 5 seconds	Refill tank or container with liquid  Check amplifier, pump and valves for function  Rotors do not turn (due to dirt, wear etc)  Pulse is defective

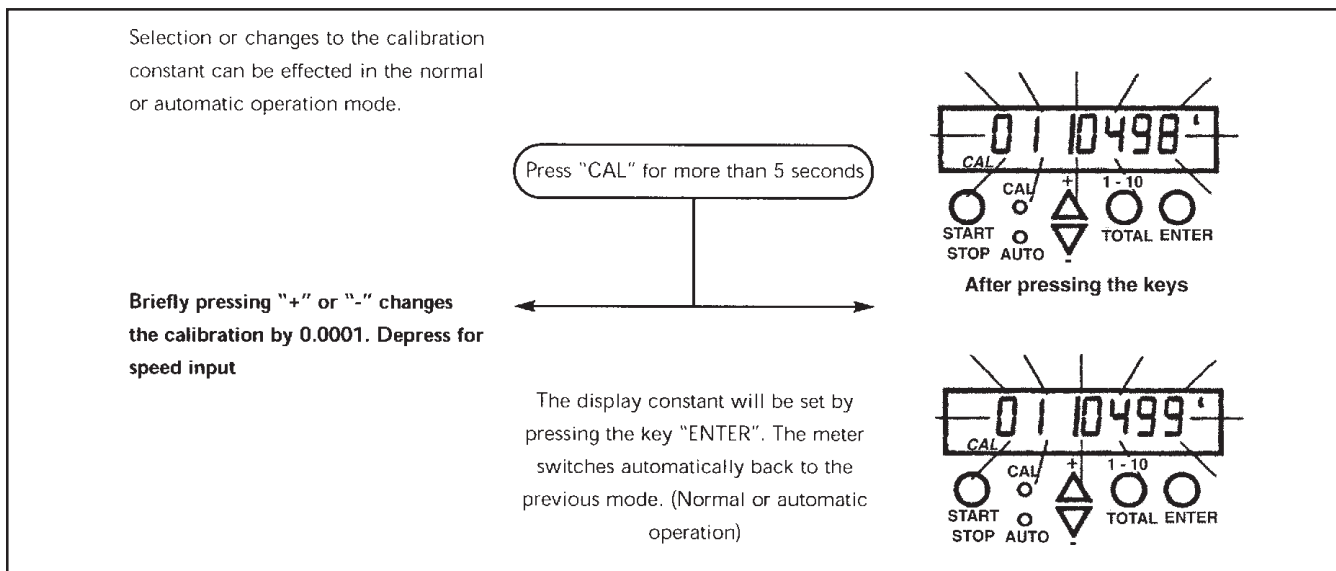

Figure 3-16 Calibration Constant

BM Oval Series

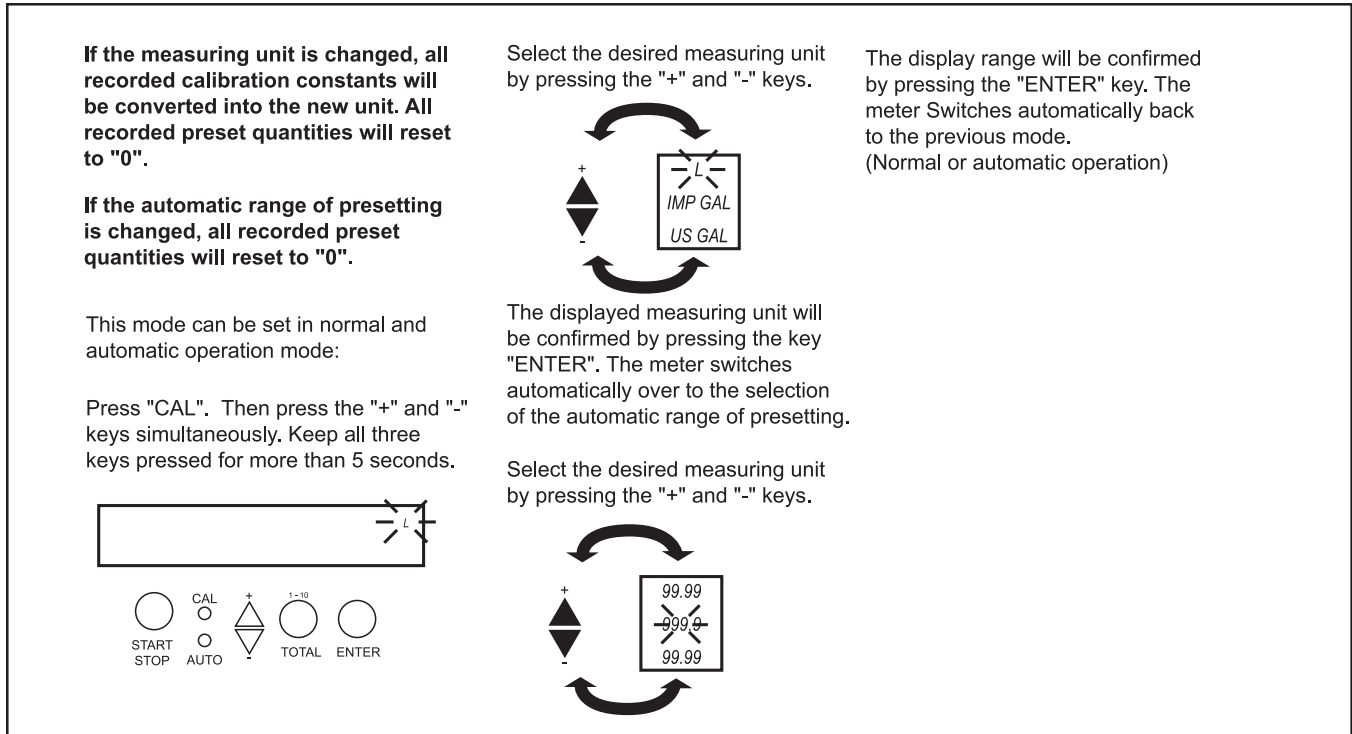

Figure 3-17 Select Measuring Unit

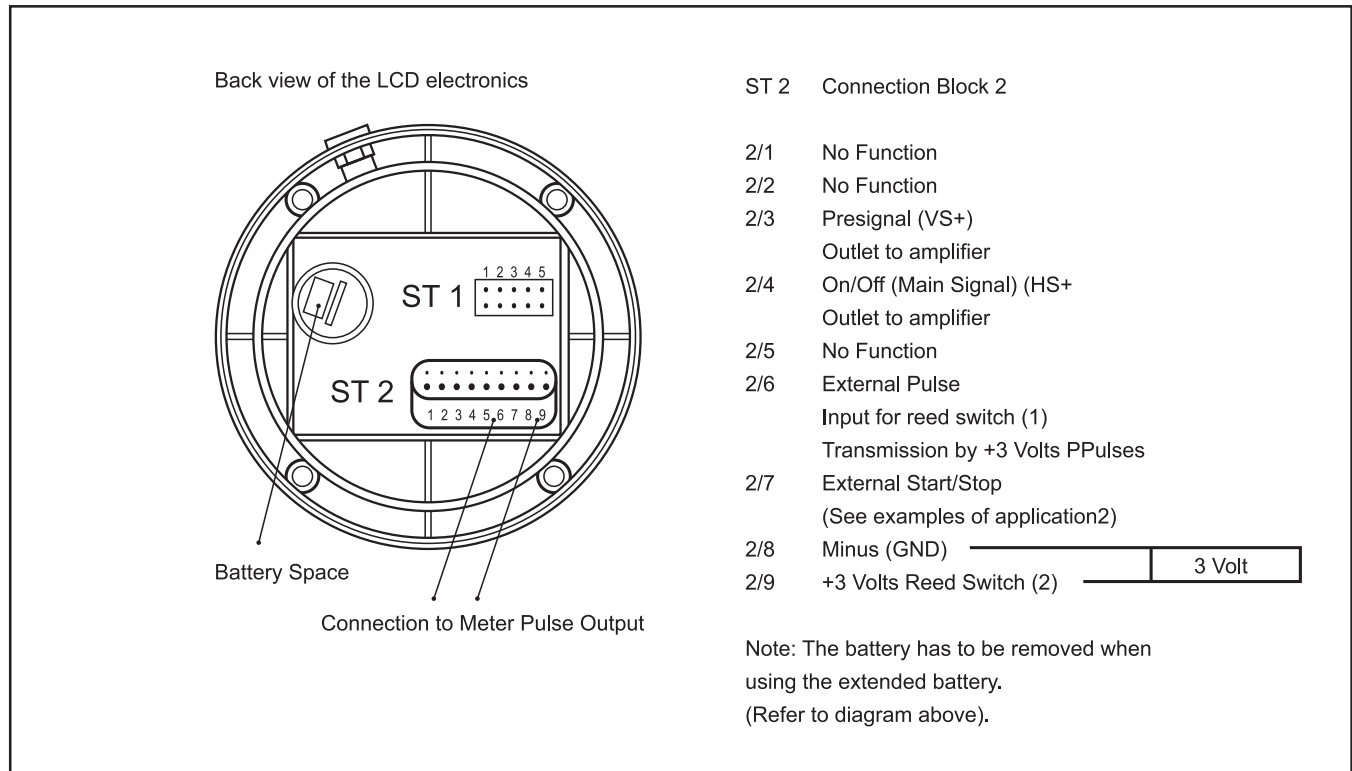

Figure 3-18 Connections Diagram

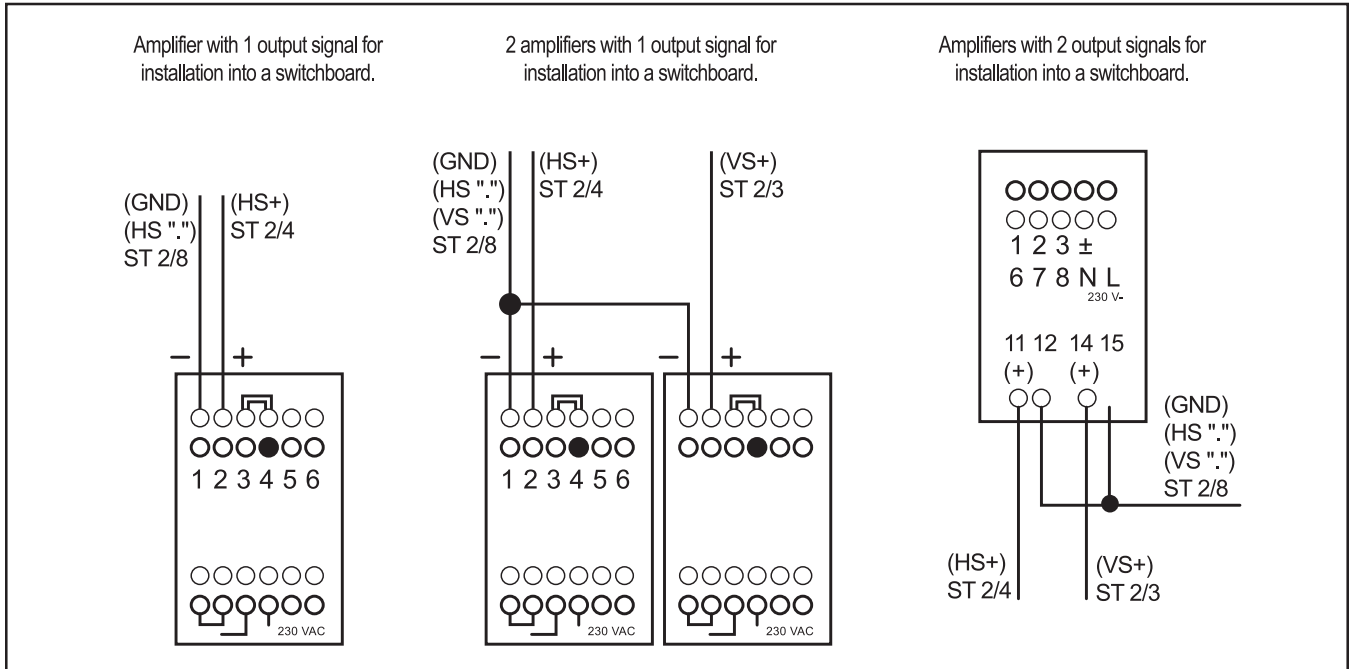

Figure 3-19 Amplifier Diagram

**Example Application:**

Connections and Diagrams are typical. Actual installations may vary from those shown in this publication.

- 1. Electronic display mounted on liquid meter; amplifier with 1 output signal for installation into a switchboard for controlling 1 valve.**  
 (Refer to Figure 3-16).

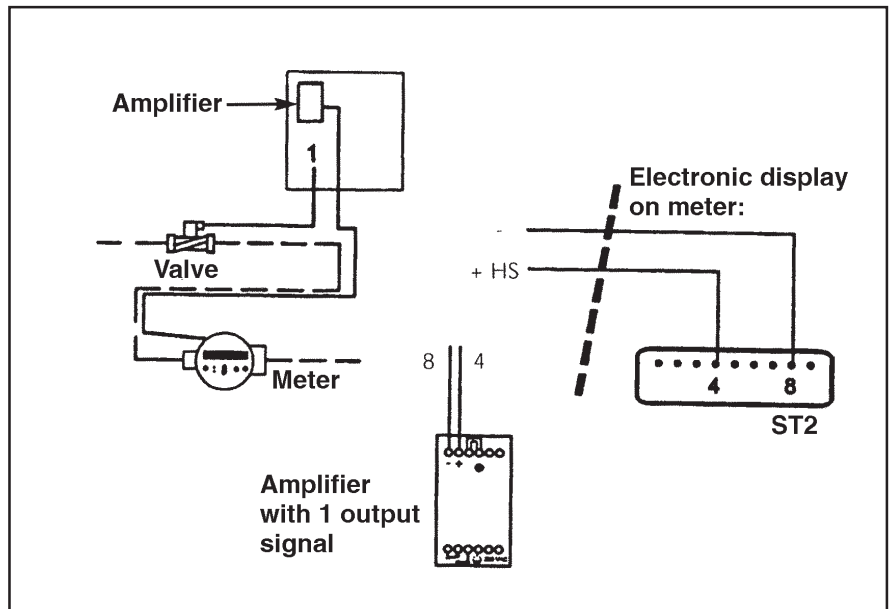

Figure 3-20 Example Application #1.

BM Oval Series

**Necessary Cable Connections;**

- A. Control cable from meter to amplifier.
- B. Voltage cable from amplifier to meter.

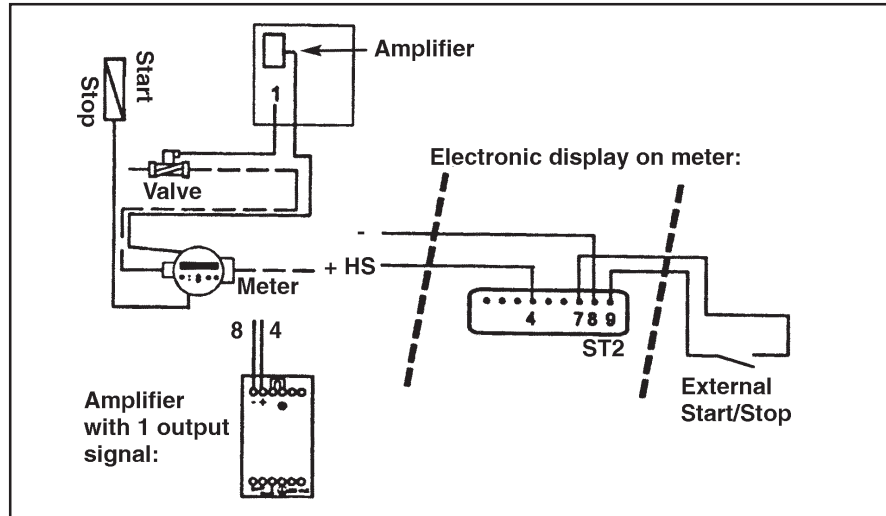

Figure 3-21 Example Application #2.

- 2. Electronic display mounted on liquid meter; amplifier with 1 output signal for installation into a switchboard for controlling 1 valve; external Start/Stop device. (Refer to Figure 3-17).

**Necessary Cable Connections:**

- A. Control cable from LC-Display to amplifier.
- B. Control cable from Start/Stop to meter.

- 3. Electronic display mounted onto quick action tap; amplifier with 1 output signal for installation into a switchboard controlling 1 valve. Liquid meter without display unit. (Refer to Figure 3-18)

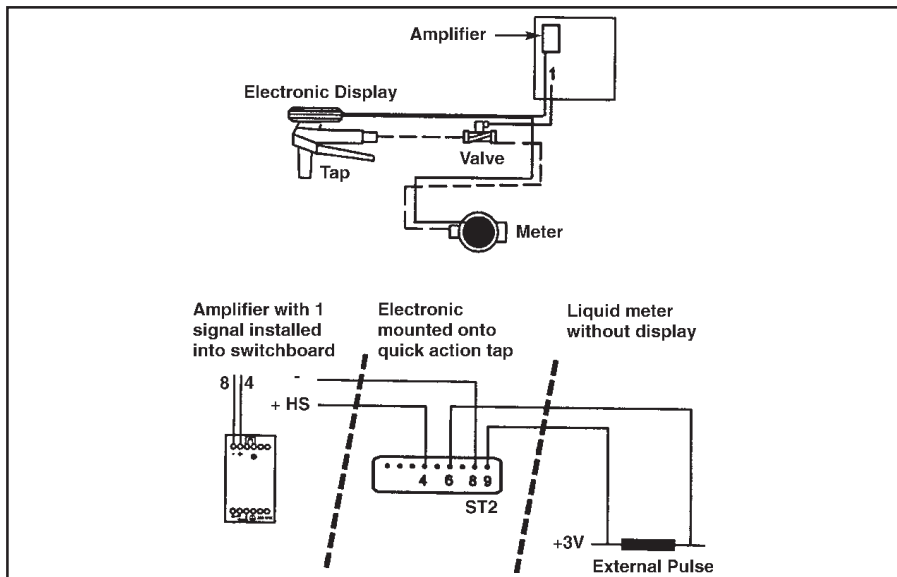

Figure 3-22 Example Application #3.

**Necessary Cable Connections:**

- A. Pulse cable from LC-Display to quick action tap (Max. 12m).
- B. Control Cable from quick action tap to amplifier.
- C. Supply voltage cable from amplifier to valve.

**Summary Tables:**

If the battery has not been removed within one minute, all registered constants will be reset to 0500.

Table 3-4 Summary Table for Normal Operation

Factory Calibration on location with calibration fluid		M4=0089, M10=0178, M40=0689, M50=1500	
Location No.		Location No.	
01	Factory Set (See Above)	06	
02		07	
03		08	
04		09	
05		10	

Table 3-5 Summary Table for Automatic Operation

PRESIGNAL			
Calibration Constant 01 to 10		Filling Quantity 01 to 10	
Location No.	Location No.	Location No.	Location No.
01	06	01	06
02	07	02	07
03	08	03	08
04	09	04	09
05	10	05	10

*THIS PAGE WAS  
INTENTIONALLY  
LEFT BLANK*

#### 4-1 General

No routine maintenance, cleaning or lubrication is required on the flowmeter. The user should establish a schedule for the periodic checking and cleaning of the strainer. Cleaning the strainer depends upon product application and time of use.

	<b>⚠ WARNING</b>
<b>METER/CONTROLLER SEAL COMPATIBILITY</b>	
<p>Products in this manual may contain metal or elastomeric seals, gaskets, O-rings or valve seats. It is the "user's" responsibility to select materials that are compatible with their process and process conditions. Using materials that are not compatible with the process or process conditions could result in the Meter or Controller leaking process fluid outside the pressure boundary of the device, resulting in personnel injury or death.</p> <p>It is recommended that the user check the Meter or Controller on a regular schedule to ensure that it is leak free as both metal and elastomeric seals, gaskets, O-rings and valve seats may change with age, exposure to process fluid, temperature, and /or pressure.</p>	

#### 4-2 Manufacturer's Maintenance Recommendations

The following items apply to all flowmeters. Users must give careful consideration to the consequences that may be the result of failure to follow manufacturer's recommendations.

1. No attempt should be made by the user to alter any physical dimension of the flowmeter or component part.
2. Do not use force to assemble or disassemble any component of the flowmeter. All components are machined to exact tolerances.
3. When an unserviceable flowmeter has been returned to the factory for rework, it must be understood that in extreme cases it may be economically impractical to repair the flowmeter.
4. Rotors are manufactured as a subassembly and are available as replacement parts, or spare parts.

## BM Oval Series

## 4-3 Disassembly - General

**⚠ WARNING**

It is not necessary to remove the flowmeter from the pipeline for disassembly. Read the ENTIRE procedure for disassembly before making ANY attempt to disassemble the meter. Serious personal injury or damage to the meter can result if it is improperly handled.

**⚠ CAUTION**

If the meter has been used for corrosive, toxic or other dangerous liquids, follow the procedures outlined in Subpart I, Sections 1910.132 through 1910.140 of the Occupational Safety and Health Standards, Federal Register No. 202-Pt II-1, or subsequent changes thereto.

Before proceeding with any disassembly, follow these steps:

1. Close all valves and isolate the meter from line pressure or back pressure.
2. If used at elevated temperatures, reduce temperature of meter (including internals) to ambient.
3. Disconnect any electrical lines to or from the meter.
  - 3a. Units with Pulse Caps: undo the conduit connector, remove pulse cap (item 9) and remove the wires from the pulse terminal board (item 5). (Refer to Figure 5-1).
  - 3b. Standard LC Displays: Mark the display orientation with a marking pen, unscrew the four large screws (item 30) on top of LC Display. Carefully separate LC Display from the plastic housing and disconnect the wires from the pulse block terminal (Refer to Figure 5-3).
  - 3c. Deluxe LC Display: Mark the display orientation with a marking pen,

remove the four retaining screws on the display face (item 16). Lift off the display unit and remove the 9 pin connector at the back of the display unit. (Refer to Figure 5-3).

4. (See Figure 5-1) Reduce the pressure inside the meter to zero by draining that section of the line which is isolated along with the meter. A method other than removing the cover (Item 4) of the meter should be used if available, i.e. strainer, drain plug, etc. If the pressure must be reduced through the flowmeter, very slowly and carefully crack the screws (Item 7) in the cover (Item 4) until the meter begins to drain slowly thereby reducing the pressure to zero.
5. (See Figure 5-1) Drain the flowmeter completely by removing the cover (Item 4) carefully.

**⚠ WARNING**

The oval shaped pockets of the metering chamber which contain the oval gears may still contain liquid. If the meter has been used for any corrosive, toxic, or other dangerous liquids, follow the procedures covered in Subpart 1, Sections 1910.132 through 1910.140 of the Occupational Safety and Health Standards, Federal Register No. 202-Pt II-1, or subsequent changes thereto.

**4-4 Disassembly - Flowmeter (Refer to Figure 5-1)**

Never use any gripping tool on any internal component of the meter. Do not drop any part of the meter or damage can occur.

1. Remove cover screws (Item 7) and remove meter body cover (Item 4).
2. Remove O-ring (Item 2) and inspect. (Replace O-ring if damaged).
3. Remove rotors (Item 3), clean and inspect (Replace rotors if damaged).

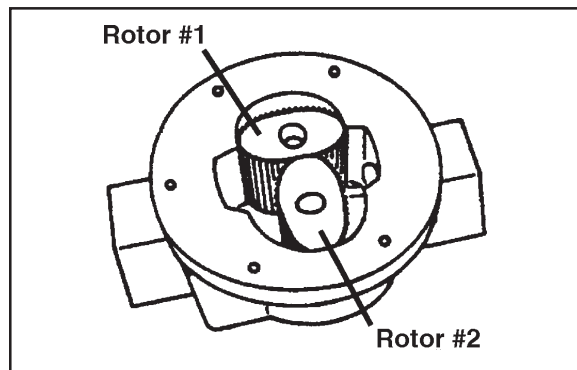

Figure 4-1 Rotor Positions

## BM Oval Series

**4-5 Cleaning**

Clean and inspect all parts removed from the flowmeter assembly. It is recommended to wash all parts thoroughly in a light weight solvent. Dry thoroughly with compressed air and/or lint free wipers.

**⚠ CAUTION**

**Do not expose any electrical parts to the cleaning medium or damage to the electrical components could result.**

**4-6 Assembly - Flowmeter (Refer to Figure 5-1)**

It is recommended that new O-rings be installed upon assembly. No lubricant is recommended or required for the O-rings.

The following steps are required for meter assembly.

1. Place the rotors (Item 3) into the meter body. The rotors to be at 90° to each other (As per Figure 4-1).

NOTE: The rotor with magnets must be placed in the body on the same side as the groove on the body (Refer to Figure 4-1).

2. Check that the smooth side of rotors (not the plug side ) is facing you when inserting the rotors, the smooth side of the rotor is the magnetic side. There is no difference between rotor 1 or rotor 2.  
Lightly rotate the rotors (Item 3) by hand (They must rotate freely).
3. If the rotor (Item 3) teeth mesh is not correct, disengage one rotor (Item 3) and rotate it one tooth clockwise or counterclockwise, then engage teeth again. Repeat this procedure until the rotors (Item 4) are properly meshed and will turn freely through several revolutions.
4. Install O-ring (Item 2).
5. Replace meter cap (Item 4).

NOTE: The locking pin in the body must line up with the hole in the cover.

6. Replace (item 7), Tighten in an alternate sequence.

**⚠ CAUTION**

**Care must be taken not to overtighten the screws (item 7) or damage may occur.**

## 4-7 Battery Replacement

---

### 1. Deluxe LCD Display (Refer to Figures 4-2 and 4-3)

A. In order to change the battery, you have to remove the electronic display unit from the meter. Replacement of the battery must take place outside of the hazardous area (if applicable).

B. Remove the four slotted screws and carefully take off the electronics display unit. (4-2)

**Note: The battery has to be replaced within one minute. If the battery has not been replaced within one minute:**

All calibration constants will reset to 0.05000,  
All preset quantities will reset to 0,  
All counters will reset to 0.

If the battery has not been replaced within one minute, remove the battery again and short circuit PIN 8 and PIN 9 on the connection block ST2 for at least 3 minutes in order to ensure a safe start-up of the electronics. A new battery may then be fitted.

## BM Oval Series

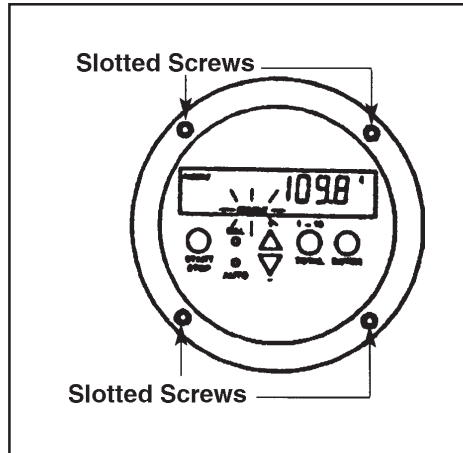

Figure 4-2 Deluxe LCD Display Assembly Parts

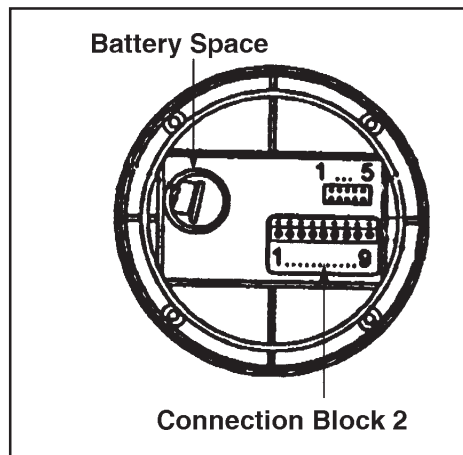

Figure 4-3 Deluxe LCD Display Assembly Parts

#### 4-8 General Maintenance for the Standard Display

- Installation, use, maintenance and de-mounting of this equipment must be carried out by authorised technicians only.
- Take good notice of the “Safety rules and precautionary measures” in the front of this manual.

The Standard Display does not require special maintenance unless it is used in low-temperature applications and/or surroundings with high humidity (above 90% annual mean). It is the customers responsibility to take all precautions to dehumidify the internal atmosphere of the Standard Display in such a way that no condensation will take place, for example by placing dry silica-gel in the casing. Furthermore, it is required to replace or dry the silica gel time to time as advised by the silica gel supplier.

##### Battery life-time:

Is influenced by several issues:

- Display update: see setup 41.
- low temperatures; the available power will be less due to battery chemistry.

To extend battery life it is advised to disable unused functions.

Check periodic:

- The condition of the casing and front panel.
- The wiring of components for reliability and ageing symptoms.
- The process accuracy. As a result of wear and tear, re-calibration of the flowmeter might be necessary. Do re-enter any subsequent K-factors alterations.
- The indication for low-battery.
- Clean the casing with soap-water; don't use any aggressive solvents as these might damage the polyester coating.

**Technical Specifications General:**

**Display:** High intensity reflective alphanumeric LCD, UV-resistant.

**Digits:** Seven 17mm (0.67") and eleven 8mm (0.31"). Various symbols and measuring units.

**Refresh rate:** Selectable via menu: 8 times/sec - 30 sec's.

**Window:** Polycarbonate window.

**Control keys** Three industrial micro-switch keys. UV-resistant polyester keypad.

**Operating temperature:** -20°C to +70°C.

**Power requirements:** 8-30 Vdc supply can be connected to power the unit.

**Option PA:** Internal Lithium battery 3.2 Vdc: average lifetime seven years dependent upon settings and sensor type.

**Sensor excitation:** Same voltage as offered to power the unit.

**Terminal connections:** Removable plug strip. Wire max. 1.5mm<sup>2</sup>.

**Data protection:** EEPROM backup of all setting. Backup total and accumulated total every minute.

**Environment CE:** EMC compliant ref: EN50081 and EN50082.

**Pulse inputs:** Type P: NPN, reed-switch,

**Frequency:** Minimum 0 Hz - maximum 7 kHz for total and flowrate. Max frequency depends on signal type and internal low-pass filter, see Section 3.2.3.5. Reed switch with low-pass filter = max. 120 Hz.

**Low-pass filter:** Available for all pulse signals.

**Selection main function:** Total or Flowrate will be displayed with 17mm digits.

**Operator Functions**

**General:** The Operator has three functions available:

- TOTAL and Flowrate are displayed.
- TOTAL can be reset by pressing CLEAR-key twice.
- After pressing SELECT, Accumulated TOTAL will be displayed.

**TOTAL:** 17mm character-size - 7 digits. Measuring units: L, m<sup>3</sup>, GAL, USGAL, KG, lb, bbl, no unit. K-factor: 7 positions 0.000010 - 9,999,999. Number of decimals: max. three. TOTAL is resettable.

**Accumulated Total:** 8mm character-size - 11 digits. Acc. Total is not resettable. Uses the same K-factor, unit and decimals as TOTAL.

---

BM Oval Series

---

**Flowrate:** 8mm character-size or 17mm character-size - 5 digits. Settings independent of TOTAL. Measuring units: mL, L, m3, Gallons, KG, ton, lb, bl, cf, rnd, no unit. Time units: second, minute, hour, day. K-factor: 7 positions 0.000010 - 9,999,999. Number of decimals: max. three.

#### Problem Solving

In this appendix, several problems are included that can occur when the Standard Display in operation.

#### **Flowmeter does not generate pulses:**

##### **Check:**

- Flowmeter, wiring and connection of terminal connectors, see Section 4-3.

Flowmeter does generate "too many pulses":

##### **Check:**

- Settings for Total and Flowrate: SETUP 11-14 and 21-27.

- Proper grounding of the Standard Display, see Section 4-3.

- Use screened wire for flowmeter signals and connect screen to terminal 3.

#### **Flowrate Displays "0/zero" while there is flow (Total is counting)**

##### **Check:**

- SETUP 22 / 25: are the K-factor and time unit correct?

- SETUP 26 / 27: The unit has to count the number of pulses according to setup 26 within the time according to setup 27.

Make sure that 27 is set to eg.10.0 seconds. The result is that the unit has at least 10 seconds time to measure the number of pulses according to setup 26.

#### **The password is unknown:**

If the password is not 1234, there is only one possibility left: call your supplier.

#### **ALARM**

When the alarm flag starts to blink an internal alarm condition has occurred. Press the "select button" several times to display the 5-digit error code. The codes are:

0001: irrecoverable display-data error: data on the display might be corrupted.

0002: irrecoverable data-storage error: the programming cycle might have gone wrong: check programmed values.

0003: error 1 and error 2 occurred simultaneously

The alarm condition will almost certainly be handled internally and if all mentioned values still appear correct, no intervention by the operator is needed. If the alarm occurs more often or stays active for a longer time, please contact your supplier.

List of DefaultSettings

Use this chart to store any changes made to the various SETUP settings:

Settings	Default Settings	Modified:	Date:
<b>1. TOTAL:</b>			
11 unit	L		
12 decimals	0000000		
13 K-factor	0000001		
14 decimals K-factor	0		
<b>2 - FLOWRATE:</b>			
21 unit	L		
22 time unit	/min		
23 decimals	0000000		
24 K-factor	0000001		
25 decimals K-factor	0		
26 calculation / pulses	10		
27 cut-off time	30.0 sec.		
<b>3 - DISPLAY</b>			
31 function	Total		
<b>4 - POWER MAN.</b>			
41 LCD-new 1 sec.			
42 mode	Operational		
<b>5 - FLOWMETER</b>			
51 signal	Reed_lp		
52 max. frequency	9999 Hz.		
<b>6 - OTHERS</b>			
64 password	0000		
65 tag number	0000000		

4-8 Troubleshooting

The troubleshooting table is presented as an aid in locating and correcting operational problems in the meter. The user must understand that every possible problem could not be listed. However, the table will provide adequate information for general field repairs. (Refer to Table 4-1).

## BM Oval Series

Table 4-1 Troubleshooting

Symptom	Possible Causes	Remedy
1. Counter will not count or Meter not giving a pulse signal.	1. Flowrate low.	1. Open the valve progressively.
	2. Pump pressure or head pressure low.	2. Taking pressure loss of the entire piping system into account, select a proper pump pressure or head pressure.
	3. Oval rotors are jammed with foreign matter.	3. Disassemble the meter body by referring to the meter body disassembly and inspection procedure. Wash clean the rotors and related components.
	4. Faulty hall effect sensor or reed switch.	4. Replace meter cap.
	5. Faulty magnet.	5. Replace rotors.
	6. Rotors installed in wrong position.	6. Refer to correct rotor positioning assembly instructions.
2. Liquid leaks.	1. Incomplete pipe seals.	1. Check and tighten pipe connections or replace gaskets.
	2. Incomplete front cover seal of the meter body.	2. Check front cover fitting bolts for tightness and replace O-Ring with new one.
3. Counts while the valve remains closed.	1. Liquid leaks from valves or pipe connections.	1. Inspect valves and pipe connections for condition.
	2. Air builds up somewhere between the valve and meter; pulsating pump pressure causes a rocking motion of the rotors.	2. Let the air escape. Provide a check valve and accumulator.
4. Meter reading inaccurate.	1. Fluid flowrate is too low or too high.	1. See "Specifications" for minimum and maximum flowrates.
	2. Air in fluid.	2. Bleed air from system.
	3. Excess wear caused by incorrect installation.	3. Check meter body and rotors. Replace as required. See "Installation" instructions.
5. Fluid will not flow through meter.	1. Foreign matter blocking rotors.	1. Dismantle meter, clean rotors (strainer must be fitted in line).
	2. Line strainer blocked.	2. Clean strainer.
	3. Damaged rotors.	3. Replace rotors (strainer must be fitted in line).
	4. Meter connections over tightened.	4. Readjust connections.
6. Reduced flow through the meter.	1. Line strainer partially blocked.	1. Clean strainer.
	2. Fluid is too viscous.	2. Max. viscosity 1000 centipoise.
7. LCD register not working	<ul style="list-style-type: none"> <li>a] Battery not connected properly</li> <li>b] Battery flat</li> <li>c] Faulty wiring connections</li> <li>d] Faulty LC display</li> <li>e] Faulty connection from LC display to Pulse PCB</li> </ul>	<ul style="list-style-type: none"> <li>a] Check battery connections</li> <li>b] Replace battery</li> <li>c] Check wiring for loose or faulty connections</li> <li>d] Replace LC display</li> <li>e] Check wiring connections</li> </ul>

## 5-1 General

---

This section contains the necessary parts required to make up any standard unit that is covered in this instruction manual. Each parts list also contains the recommended spare and replacement parts denoted by an asterisk. For items that are not listed or require additional information, consult the factory. When ordering, the following information must be furnished:

Part number and description  
Model number of flowmeter  
Serial number of flowmeter  
Quantity required

When ordering items of a material or special construction not indicated in the Parts List, furnish the following information so that the part number of the item can be determined.

Item number and description  
Specific material of item  
Model number of flowmeter  
Serial number of flowmeter  
Quantity required

**Note: Parts lists are separated into Pulse and Mechanical Meters and Displays.**

BM Oval Series

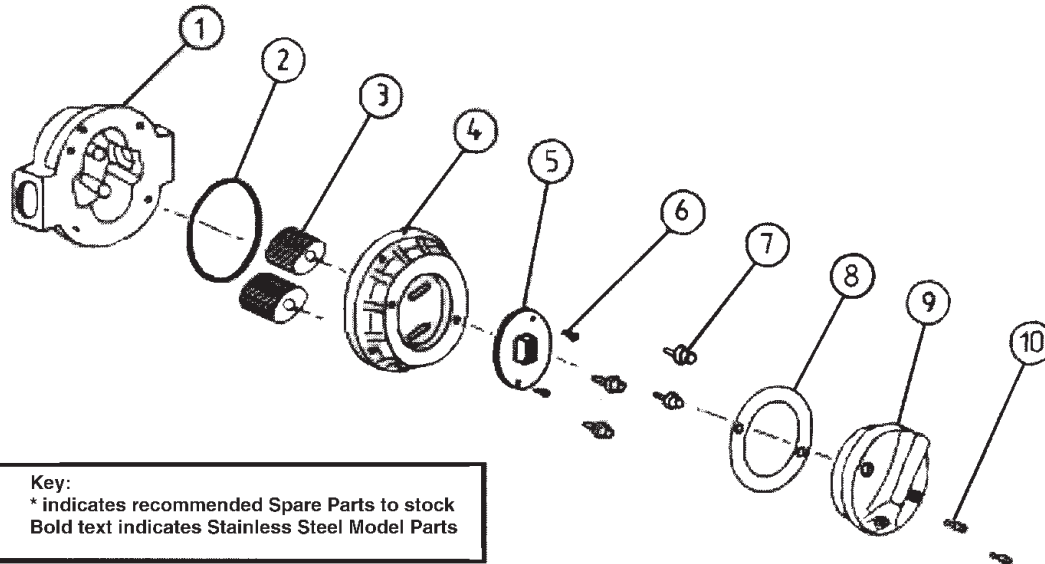

Item No.	No. Off.	Rec. Parts	Part or Set (Order from this column only)	Part Description
1	1		MS298B	Meter Body 1/2" BSP (Aluminium)
1	1		MS298N	Meter Body 1/2" NPT (Aluminium)
<b>1</b>	<b>1</b>		<b>MS337B</b>	<b>Meter Body 1/2" BSP (Stainless Steel)</b>
<b>1</b>	<b>1</b>		<b>MS337N</b>	<b>Meter Body 1/2" NPT (Stainless Steel)</b>
2	1	*	BS145	"O" Ring (NBR)
2	1	*	BS145E	"O" Ring (EPDM)
2	1	*	BS145TE	"O" Ring (Teflon)
2	1	*	BS145V	"O" Ring (Viton)
3	2	*	MS342S	Rotors PPS (Polyphenylene Sulfide Resins)
<b>3</b>	<b>2</b>	*	<b>MS342-1S</b>	<b>Rotors (Stainless Steel)</b>
3	2	*	MS342TS	High Temperature Rotors (PPS)
3	2	*	MS342HS	High Viscosity Rotors (PPS)
3	2	*	MS342HTS	HighViscosity/High Temperature Rotors (PPS)
<b>3</b>	<b>2</b>	*	<b>MS342-1HS</b>	<b>High Viscosity Rotors (Stainless Steel)</b>
4	1		MS297	Meter Cap (Aluminium)
<b>4</b>	<b>1</b>		<b>MS338</b>	<b>Meter Cap (Stainless Steel)</b>
5	1	*	MS344-R	PCB (Standard Reed Switch)
5	1	*	MS344-HE	PCB (Hall Effect Sensor)
5	1		MS344-R/HE	PCB ( 1 Reed Switch & 1 Hall Effect Sensor)
6	2		MS284S	PCB Board Screws
7	4	*	MS346S	Meter Cap Screws (Standard)
<b>7</b>	<b>4</b>	*	<b>MS350S</b>	<b>Meter Cap Screws (Stainless Steel)</b>
8	1	*	MS340	Pulser Cap Gasket
9	1		MS296	Pulser Cap (Aluminium) 16mm Conduit Thread
9	1		MS296N	Pulser Cap (Aluminum) 1/2" NPT Thread
<b>9</b>	<b>1</b>		<b>MS339</b>	<b>Pulser Cap (Stainless Steel) 16mm Conduit Thread</b>
<b>9</b>	<b>1</b>		<b>MS339N</b>	<b>Pulser Cap (Stainless Steel) 1/2" NPT Thread</b>
10	2		MS347S	Pulser Cap Screw (Stainless Steel)
11	1		MS37	Warning Label (Not Shown)
12	1		MS14	Explosion Proof Approval Label (Not Shown)
13	1		Customer to Specify	Legend Plate (Not Shown) inc. Hammer Screws

Figure 5-1 Exploded Parts Drawing for Model BM04 Pulse Meter

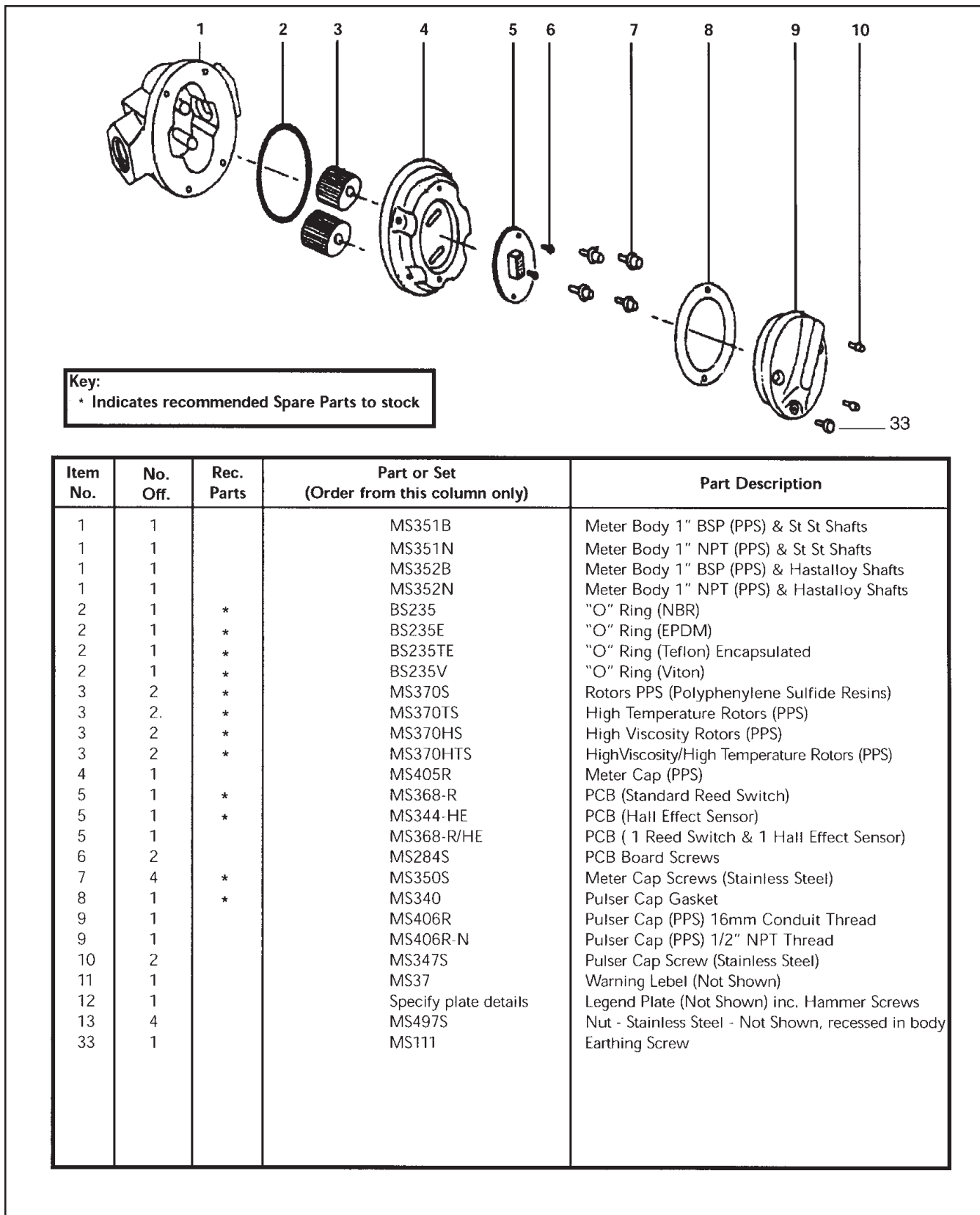
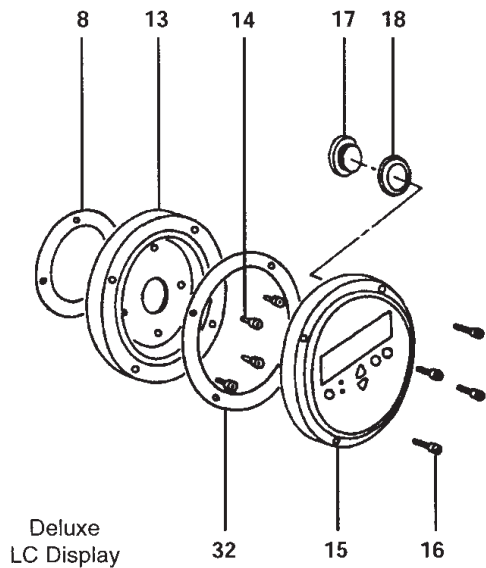

Figure 5-2 Exploded Parts Drawing for Model BM07 Pulse Meter

BM Oval Series



Item No.	No. Off.	Rec. Parts	Part or Set (Order from this column only)	Part Description
			<b>MS500S</b>	<b>Deluxe LCD Display (Complete)</b>
13	1		MS349	Mounting Adaptor Plate
14	4	*	MS117S	Adaptor Screws
15	1	*	MS69	LC Display Unit
16	4	*	MS118S	LC Display Mounting Screws
17	1	*	MS127	Battery Retaining Screw
18	1	*	MS126	Battery (Standard) CR2040
19	1	*	MS68	Connector and Cable (Not Shown)
20	1		MS87	PTB Approval Label (Not Shown)
21	1	*	MS128	Extended Life Battery 2/3 AA (Not Shown)
				NOTE: Not Suitable for Intrinsic use
32	1	*	MS307	Gasket

Figure 5-3 Exploded Display Parts Drawings for Models BM04 and BM07 Pulse Meter

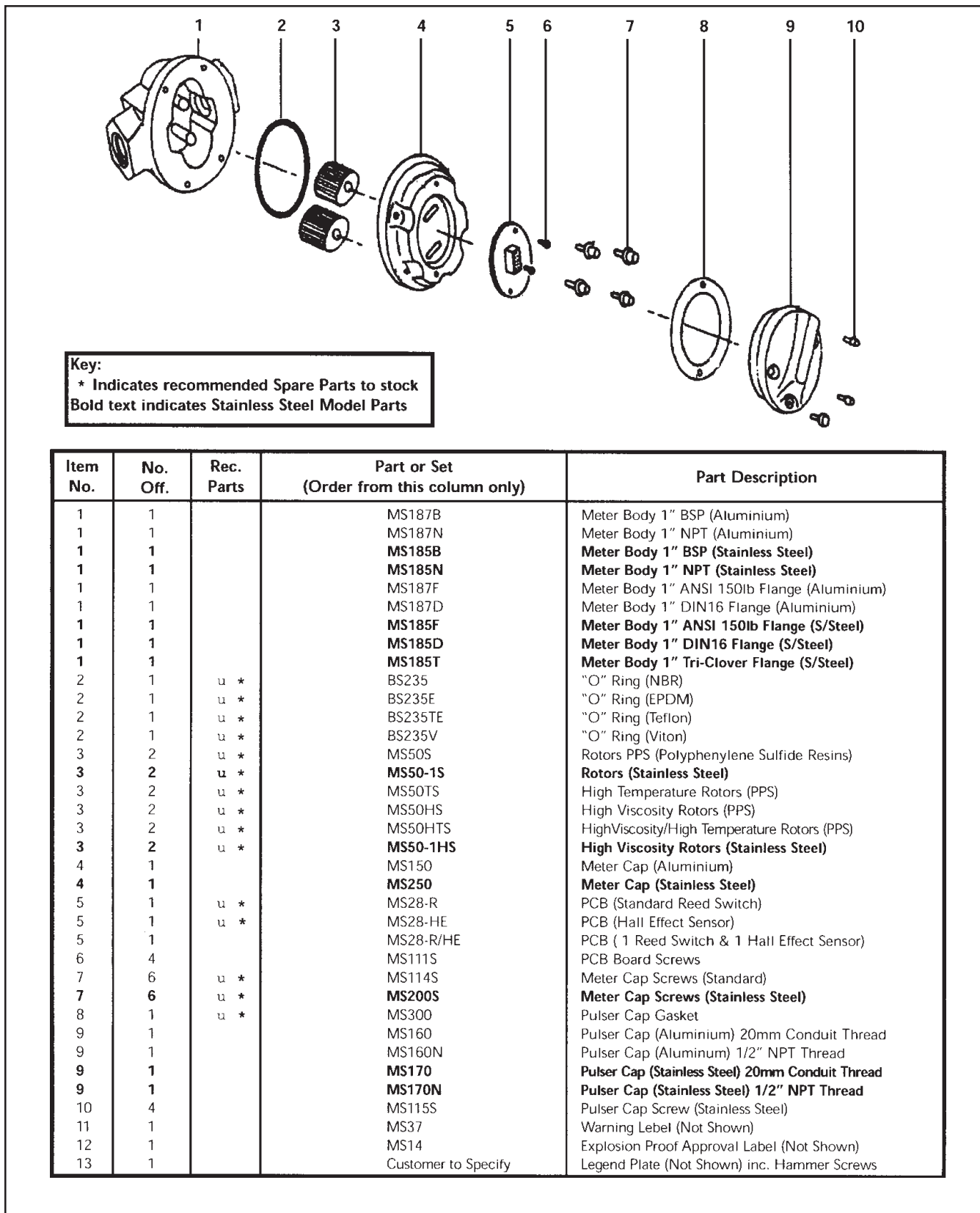
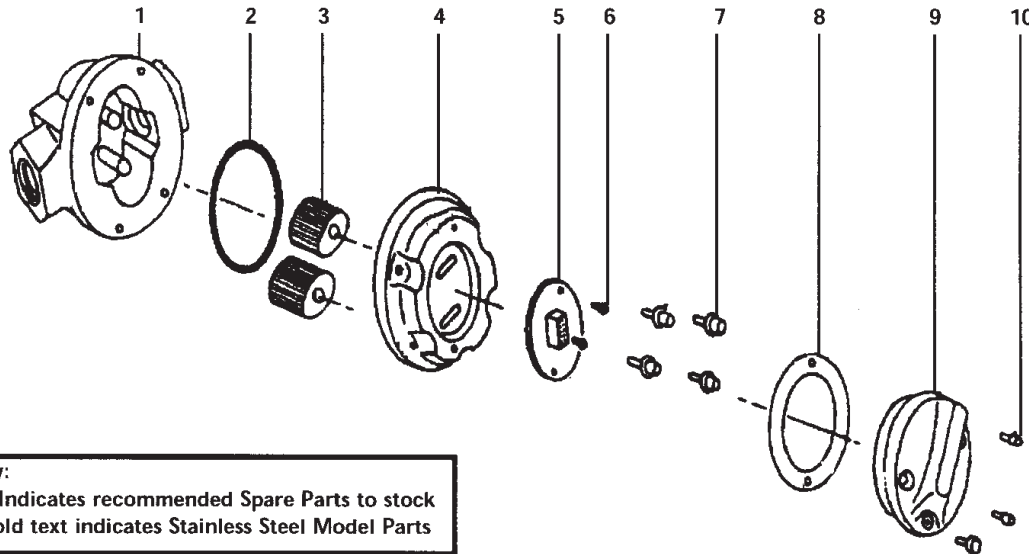

Figure 5-4 Exploded Parts Drawing for Model BM10 Pulse Meter

BM Oval Series



**Key:**  
 \* Indicates recommended Spare Parts to stock  
 Bold text indicates Stainless Steel Model Parts

Item No.	No. Off.	Rec. Parts	Part or Set (Order from this column only)	Part Description
1	1		MS191B	Meter Body 1 1/2" BSP (Aluminium)
1	1		MS191N	Meter Body 1 1/2" NPT (Aluminium)
<b>1</b>	<b>1</b>		<b>MS189B</b>	<b>Meter Body 1 1/2" BSP (Stainless Steel)</b>
<b>1</b>	<b>1</b>		<b>MS189N</b>	<b>Meter Body 1 1/2" NPT (Stainless Steel)</b>
1	1		MS191F	Meter Body 1 1/2" ANSI 150lb Flange (Aluminium)
1	1		MS191D	Meter Body 1 1/2" DIN16 Flange (Aluminium)
<b>1</b>	<b>1</b>		<b>MS189F</b>	<b>Meter Body 1 1/2" ANSI 150lb Flange (S/Steel)</b>
<b>1</b>	<b>1</b>		<b>MS189D</b>	<b>Meter Body 1 1/2" DIN16 Flange (S/Steel)</b>
2	1	*	BS243	"O" Ring (NBR)
2	1	*	BS243E	"O" Ring (EPDM)
2	1	*	BS243TE	"O" Ring (Teflon)
2	1	*	BS243V	"O" Ring (Viton)
3	2	*	MS58S	Rotors PPS (Polyphenylene Sulfide Resins)
<b>3</b>	<b>2</b>	*	<b>MS58-1S</b>	<b>Rotors (Stainless Steel)</b>
3	2	*	MS58TS	High Temperature Rotors (PPS)
3	2	*	MS58HS	High Viscosity Rotors (PPS)
3	2	*	MS58HTS	HighViscosity/High Temperature Rotors (PPS)
<b>3</b>	<b>2</b>	*	<b>MS58-1HS</b>	<b>High Viscosity Rotors (Stainless Steel)</b>
4	1		MS220	Meter Cap (Aluminium)
<b>4</b>	<b>1</b>		<b>MS221</b>	<b>Meter Cap (Stainless Steel)</b>
5	1	*	MS201-R	PCB (Standard Reed Switch)
5	1	*	MS201-HE	PCB (Hall Effect Sensor)
5	1		MS201-R/HE	PCB ( 1 Reed Switch & 1 Hall Effect Sensor)
6	4		MS284S	PCB Board Screws
7	6	*	MS116S	Meter Cap Screws (Standard)
<b>7</b>	<b>6</b>	*	<b>MS180S</b>	<b>Meter Cap Screws (Stainless Steel)</b>
8	1	*	MS300	Pulsar Cap Gasket
9	1		MS160	Pulsar Cap (Aluminium) 20mm Conduit Thread
9	1		MS160N	Pulsar Cap (Aluminium) 1/2" NPT Thread
<b>9</b>	<b>1</b>		<b>MS170</b>	<b>Pulsar Cap (Stainless Steel) 20mm Conduit Thread</b>
<b>9</b>	<b>1</b>		<b>MS170N</b>	<b>Pulsar Cap (Stainless Steel) 1/2" NPT Thread</b>
10	4		MS115S	Pulsar Cap Screw (Stainless Steel)
11	1		MS37	Warning Label (Not Shown)
12	1		MS14	Explosion Proof Approval Label (Not Shown)
13	1		Customer to Specify	Legend Plate (Not Shown) inc. Hammer Screws

Figure 5-5 Exploded Parts Drawings for Model BM40 Pulse Meter

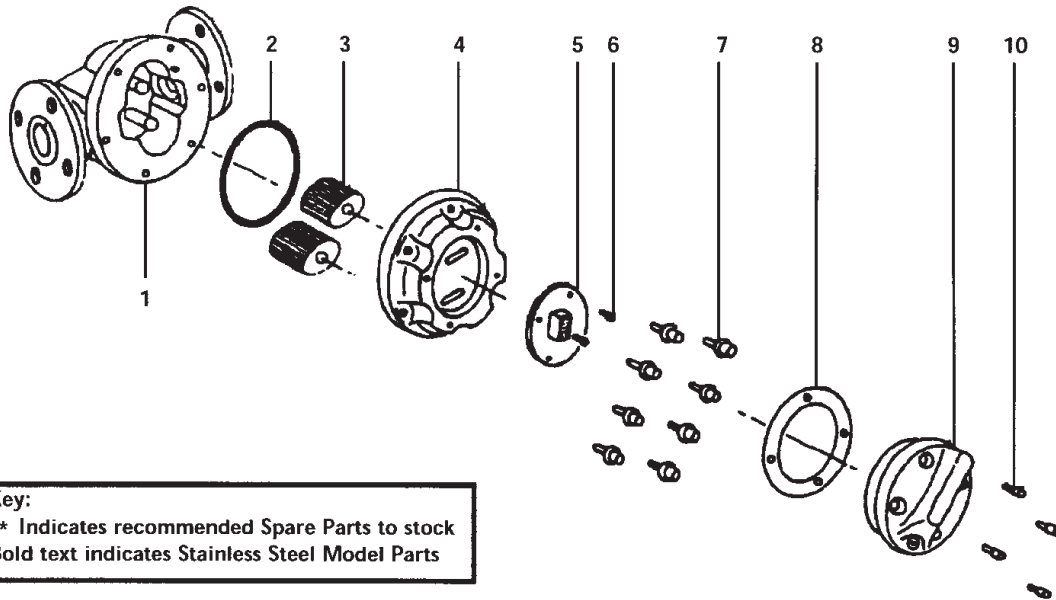

**Key:**  
 \* Indicates recommended Spare Parts to stock  
 Bold text indicates Stainless Steel Model Parts

Item No.	No. Off.	Rec. Parts	Part or Set (Order from this column only)	Part Description
1	1		MS283F	Meter Body 2" ANSI 150lb Flange (Aluminium)
1	1		MS281D	Meter Body 2" DIN16 Flange (Aluminium)
<b>1</b>	<b>1</b>		<b>MS281F</b>	<b>Meter Body 2" ANSI 150lb Flange (S/Steel)</b>
<b>1</b>	<b>1</b>		<b>MS283D</b>	<b>Meter Body 2" DIN16 Flange (S/Steel)</b>
2	1	*	BS252	"O" Ring (NBR)
2	1	*	BS252E	"O" Ring (EPDM)
2	1	*	BS252TE	"O" Ring (Teflon)
2	1	*	BS252V	"O" Ring (Viton)
3	2	*	MS147S	Rotors PPS (Polyphenylene Sulfide Resins)
3	2	*	MS147TS	High Temperature Rotors (PPS)
3	2	*	MS147HS	High Viscosity Rotors (PPS)
3	2	*	MS147HTS	High Viscosity/High Temperature Rotors (PPS)
4	1		MS230	Meter Cap (Aluminium)
<b>4</b>	<b>1</b>		<b>MS231</b>	<b>Meter Cap (Stainless Steel)</b>
5	1	*	MS201-R	PCB (Standard Reed Switch)
5	1	*	MS201-HE	PCB (Hall Effect Sensor)
5	1		MS201-R/HE	PCB ( 1 Reed Switch & 1 Hall Effect Sensor)
6	4		MS284S	PCB Board Screws
7	6	*	MS243S	Meter Cap Screws (Standard)
<b>7</b>	<b>6</b>	*	<b>MS282S</b>	<b>Meter Cap Screws (Stainless Steel)</b>
8	1	*	MS300	Pulsor Cap Gasket
9	1		MS160	Pulsor Cap (Aluminium) 20mm Conduit Thread
9	1		MS160N	Pulsor Cap (Aluminium) 1/2" NPT Thread
<b>9</b>	<b>1</b>		<b>MS170</b>	<b>Pulsor Cap (Stainless Steel) 20mm Conduit Thread</b>
<b>9</b>	<b>1</b>		<b>MS170N</b>	<b>Pulsor Cap (Stainless Steel) 1/2" NPT Thread</b>
10	4		MS115S	Pulsor Cap Screw (Stainless Steel)
11	1		MS37	Warning Label (Not Shown)
12	1		MS14	Explosion Proof Approval Label (Not Shown)
13	1		Customer to Specify	Legend Plate (Not Shown) inc. Hammer Screws

Figure 5-6 Exploded Parts Drawing for Model BM50 Pulse Meter

BM Oval Series

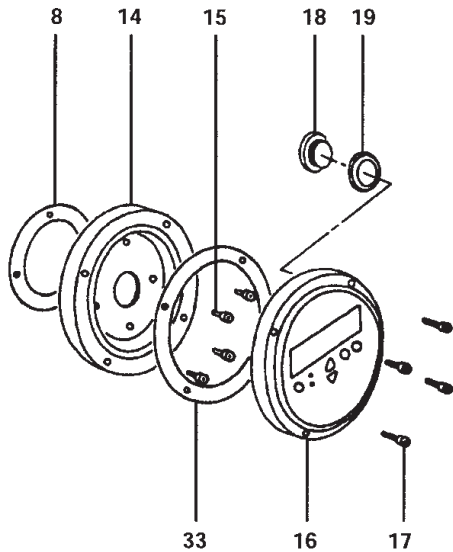

Item No.	No. Off.	Rec. Parts	Part or Set (Order from this column only)	Part Description
14	1		<b>MS280S</b>	<b>Deluxe LCD Display (Complete)</b>
15	4	u *	MS279	Mounting Adaptor Plate
16	1	u *	MS117S	Adaptor Screws
17	4	u *	MS69	LC Display Unit
18	1	u *	MS118S	LC Display Mounting Screws
19	1	u *	MS127	Battery Retaining Screw
20	1	u *	MS126	Battery (Standard) CR2040
21	1	u *	MS68	Connector and Cable (Not Shown)
22	1	u *	MS87	PTB Approval Label (Not Shown)
			MS128	Extended Life Battery 2/3 AA (Not Shown)
33	1	u *	MS307	NOTE: Note Suitable for Intrinsic Use Gasket

Figure 5-7 Exploded Display Parts Drawings for Models BM10/BM40/BM50

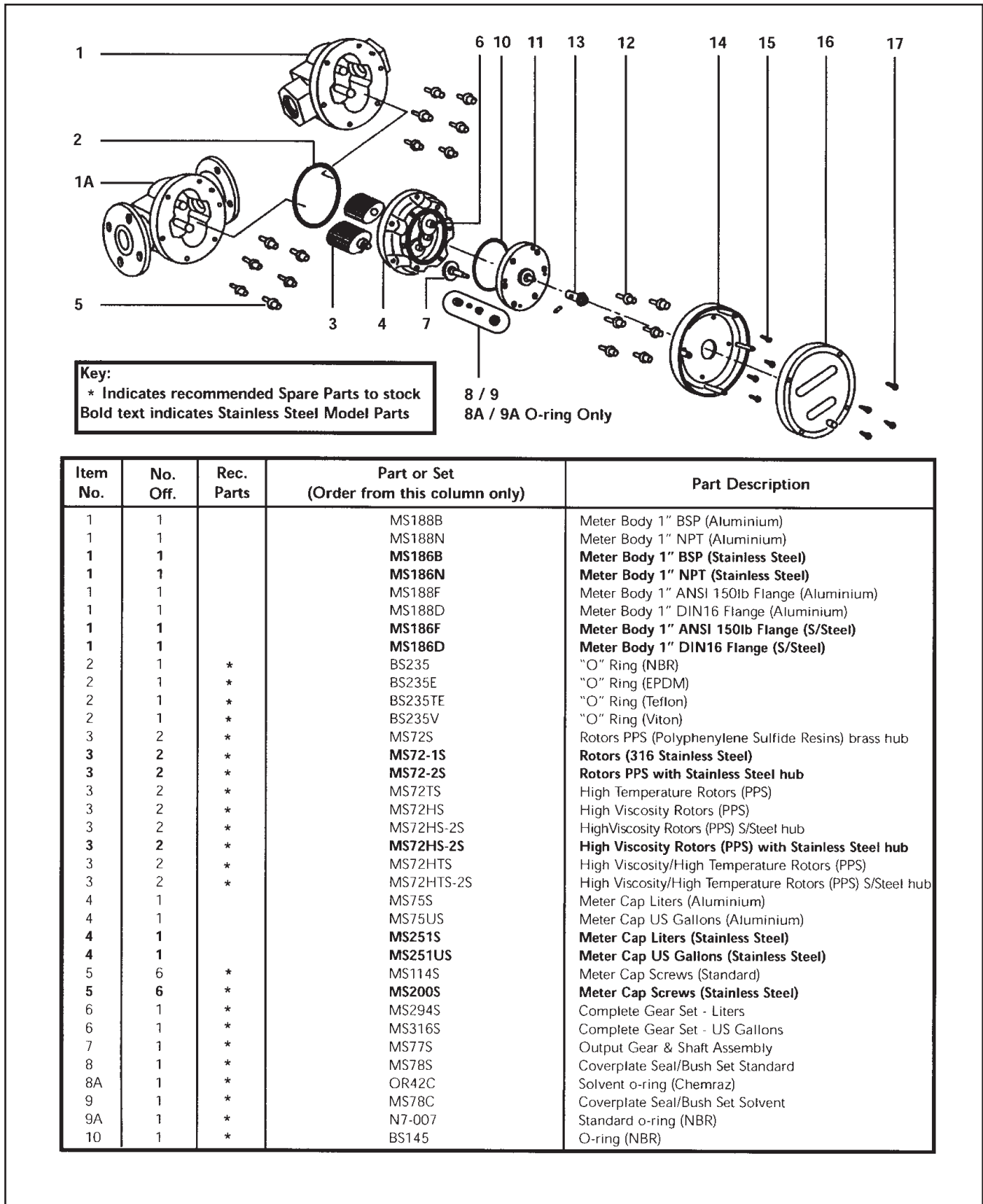

Figure 5-8 Exploded Parts Drawing - BM10 Mechanical Meter

## BM Oval Series

Item No.	No. Off.	Rec. Parts	Part or Set (Order from this column only)	Part Description
10	1	*	BS145E	O-ring (EPDM)
10	1	*	BS145TE	O-ring (Teflon)
10	1	*	BS145V	O-ring (Viton)
11	1		MS99S	Coverplate (Aluminium) includes bush
<b>11</b>	<b>1</b>		<b>MS99-1S</b>	<b>Coverplate (Stainless Steel) includes bush</b>
12	6	*	MS312S	Coverplate Screws
<b>12</b>	<b>6</b>	*	<b>MS313S</b>	<b>Coverplate Screws (Stainless Steel)</b>
13	1	*	MS83S	Bevel Gear Set
14	1		MS140	Bottom Register Coverplate
15	4	*	MS111S	Mounting Screws
16	1	*	MS141S	Register Assembly with Coverplate - Liters
16	1	*	MS141US	Register Assembly with Coverplate - US Gallons
17	4	*	MS129S	Register Body Screws
18	1		Customer to specify model	Legend Plate (Not Pictured) includes Hammer Screws
19	1		MS37	Warning Label (Not Pictured)

Figure 5-8 BM10 Mechanical Meter (continued)

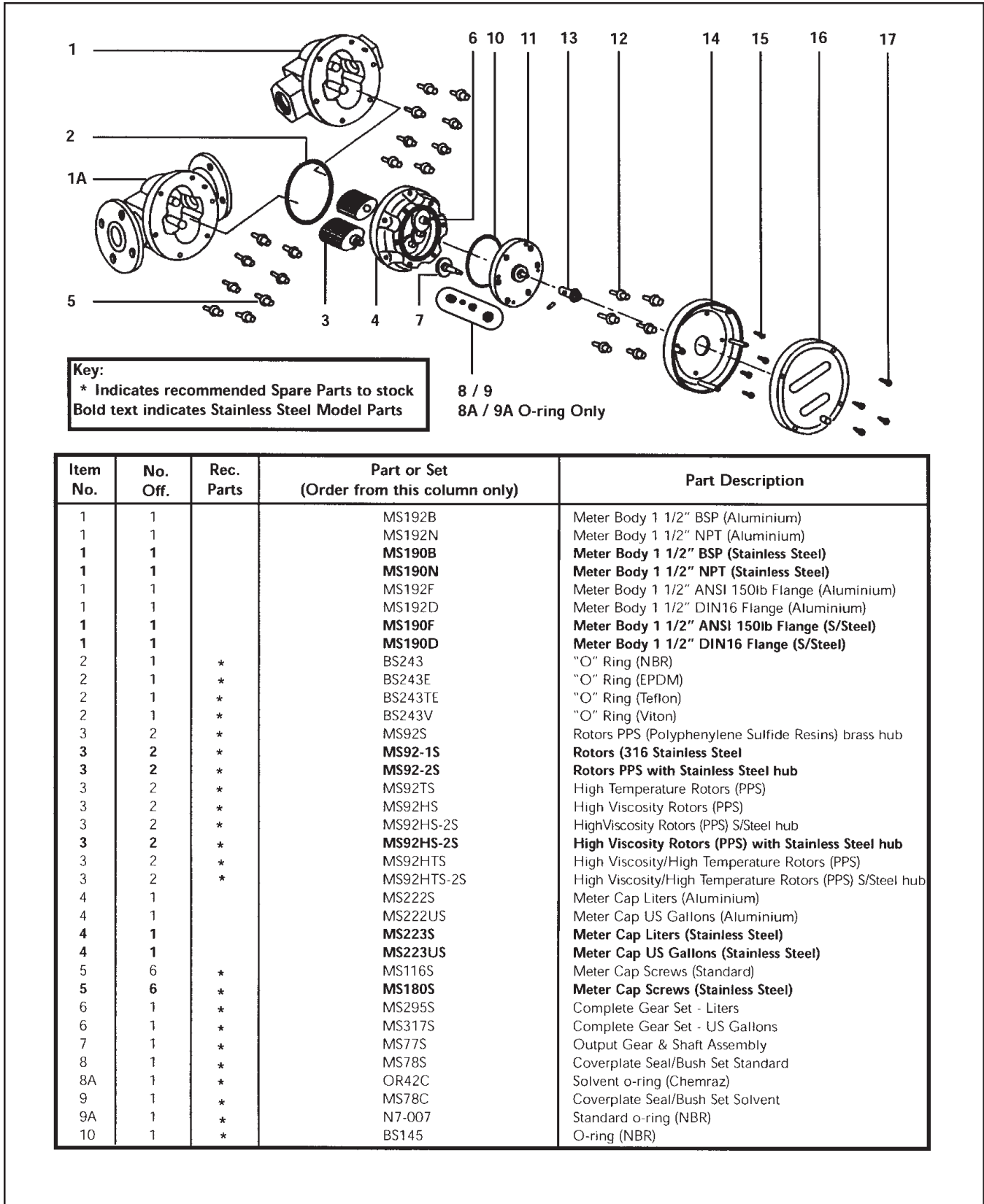
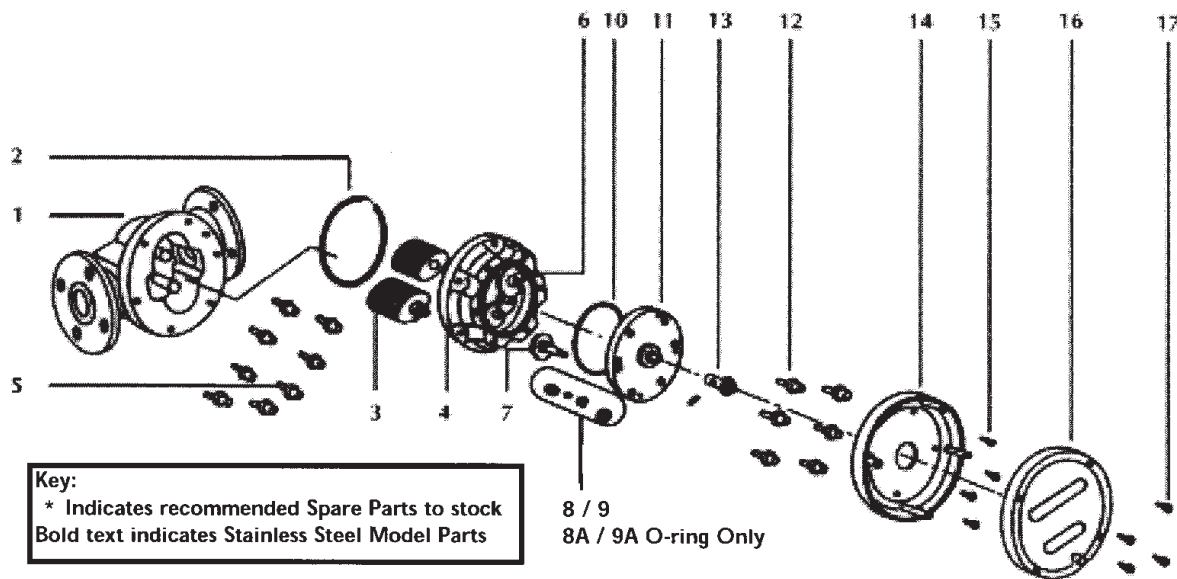

Figure 5-9 Exploded Parts Drawing - BM40 Mechanical Meter

## BM Oval Series

Item No.	No. Off.	Rec. Parts	Part or Set (Order from this column only)	Part Description
10	1	*	BS145E	O-ring (EPDM)
10	1	*	BS145TE	O-ring (Teflon)
10	1	*	BS145V	O-ring (Viton)
11	1		MS99S	Coverplate (Aluminium) includes bush
<b>11</b>	<b>1</b>		<b>MS99-1S</b>	<b>Coverplate (Stainless Steel) includes bush</b>
12	6	*	MS312S	Coverplate Screws
<b>12</b>	<b>6</b>	*	<b>MS313S</b>	<b>Coverplate Screws (Stainless Steel)</b>
13	1	*	MS83S	Bevel Gear Set
14	1		MS140	Bottom Register Coverplate
15	4	*	MS111S	Mounting Screws
16	1	*	MS141S	Register Assembly with Coverplate - Liters
16	1	*	MS141US	Register Assembly with Coverplate - US Gallons
17	4	*	MS129S	Register Body Screws
18	1		Customer to specify model	Legend Plate (Not Pictured) includes Hammer Screws
19	1		MS37	Warning Label (Not Pictured)

Figure 5-9 BM40 Mechanical Meter (continued)



Item No.	No. Off.	Rec. Parts	Part or Set (Order from this column only)	Part Description
1	1		MS483F	Meter Body 2" ANSI 150lb Flange (Aluminium)
1	1		MS483D	Meter Body 2" DIN16 Flange (Aluminium)
1	1		<b>MS481F</b>	<b>Meter Body 2" ANSI 150lb Flange (S/Steel)</b>
1	1		<b>MS481D</b>	<b>Meter Body 2" DIN16 Flange (S/Steel)</b>
2	1	*	BS252	"O" Ring (NBR)
2	1	*	BS252E	"O" Ring (EPDM)
2	1	*	BS252TE	"O" Ring (Teflon)
2	1	*	BS252V	"O" Ring (Viton)
3	2	*	<b>MS105-1S</b>	<b>Rotors 316 Stainless Steel with S/Steel Pinion</b>
3	2	*	<b>MS105-2S</b>	<b>Rotors PPS with Stainless Steel Pinion</b>
3	2	*	MS105HS-2S	HighViscosity Rotors (PPS) with S/Steel Pinion
3	2	*	MS105TS-2S	High Temperature Rotors (PPS) with S/Steel Pinion
3	2	*	MS105HTS-2S	High Viscosity/High Temperature Rotors (PPS) S/SteelPinion
3	1	*	MS105-1HS	High Viscosity Rotors (Stainless Steel) with S/Steel Pinion
4	1		MS232S	Meter Cap Liters (Aluminium)
4	1		MS335US	Meter Cap US Gallons (Aluminium)
4	1		<b>MS233S</b>	<b>Meter Cap Liters (Stainless Steel)</b>
4	1		<b>MS425US</b>	<b>Meter Cap US Gallons (Stainless Steel)</b>
5	6	*	MS243S	Meter Cap Screws (Standard)
5	6	*	<b>MS282S</b>	<b>Meter Cap Screws (Stainless Steel)</b>
6	1	*	MS363S	Complete Gear Set - Liters
6	1	*	MS470S	Complete Gear Set - US Gallons
7	1	*	MS77S	Output Gear & Shaft Assembly
8	1	*	MS78S	Coverplate Seal/Bush Set Standard
8A	1	*	PF75-007	Solvent o-ring (Chemraz)
9	1	*	MS78C	Coverplate Seal/Bush Set Solvent
9A	1	*	N7-007	Standard o-ring (NBR)
10	1	*	BS145	O-ring (NBR)

Figure 5-10 Exploded Parts Drawing - BM50 Mechanical Meter

## BM Oval Series

Item No.	No. Off.	Rec. Parts	Part or Set (Order from this column only)	Part Description
10	1	*	BS145E	O-ring (EPDM)
10	1	*	BS145TE	O-ring (Teflon)
10	1	*	BS145V	O-ring (Viton)
11	1		MS99S	Coverplate (Aluminium) includes bush
<b>11</b>	<b>1</b>		<b>MS99-1S</b>	<b>Coverplate (Stainless Steel) includes bush</b>
12	6	*	MS312S	Coverplate Screws
<b>12</b>	<b>6</b>	*	<b>MS313S</b>	<b>Coverplate Screws (Stainless Steel)</b>
13	1	*	MS83S	Bevel Gear Set
14	1		MS140	Bottom Register Coverplate
15	4	*	MS111S	Mounting Screws
16	1	*	MS141S	Register Assembly with Coverplate - Liters
16	1	*	MS141US	Register Assembly with Coverplate - US Gallons
17	4	*	MS129S	Register Body Screws
18	1		Customer to specify model	Legend Plate (Not Pictured) includes Hammer Screws
19	1		MS37	Warning Label (Not Pictured)

Figure 5-10 BM50 Mechanical Meter (continued)

**Installation and Operation Manual**

X-PD-BM-Ovals-eng

Part Number: 541B031AAG

January, 2009

**BM Oval Series**

---

*THIS PAGE WAS  
INTENTIONALLY  
LEFT BLANK*

## BM Oval Series

### LIMITED WARRANTY

Seller warrants that the Goods manufactured by Seller will be free from defects in materials or workmanship under normal use and service and that the Software will execute the programming instructions provided by Seller until the expiration of the earlier of twelve (12) months from the date of initial installation or eighteen (18) months from the date of shipment by Seller. Products purchased by Seller from a third party for resale to Buyer ("Resale Products") shall carry only the warranty extended by the original manufacturer.

All replacements or repairs necessitated by inadequate preventive maintenance, or by normal wear and usage, or by fault of Buyer, or by unsuitable power sources or by attack or deterioration under unsuitable environmental conditions, or by abuse, accident, alteration, misuse, improper installation, modification, repair, storage or handling, or any other cause not the fault of Seller are not covered by this limited warranty, and shall be at Buyer's expense.

Goods repaired and parts replaced during the warranty period shall be in warranty for the remainder of the original warranty period or ninety (90) days, whichever is longer. This limited warranty is the only warranty made by Seller and can be amended only in a writing signed by an authorized representative of Seller.

### BROOKS SERVICE AND SUPPORT

Brooks is committed to assuring all of our customers receive the ideal flow solution for their application, along with outstanding service and support to back it up. We operate first class repair facilities located around the world to provide rapid response and support. Each location utilizes primary standard calibration equipment to ensure accuracy and reliability for repairs and recalibration and is certified by our local Weights and Measures Authorities and traceable to the relevant International Standards.

Visit [www.BrooksInstrument.com](http://www.BrooksInstrument.com) to locate the service location nearest to you.

### START-UP SERVICE AND IN-SITU CALIBRATION

Brooks Instrument can provide start-up service prior to operation when required.

For some process applications, where ISO-9001 Quality Certification is important, it is mandatory to verify and/or (re)calibrate the products periodically. In many cases this service can be provided under in-situ conditions, and the results will be traceable to the relevant international quality standards.

### CUSTOMER SEMINARS AND TRAINING

Brooks Instrument can provide customer seminars and dedicated training to engineers, end users and maintenance persons.

Please contact your nearest sales representative for more details.

### HELP DESK

In case you need technical assistance:

Americas	☎ 1-888-554-FLOW	
Europe	☎ +(31) 318 549 290	Within Netherlands ☎ 0318 549 290
Asia	☎ +011-81-3-5633-7100	

Due to Brooks Instrument's commitment to continuous improvement of our products, all specifications are subject to change without notice.

### TRADEMARKS

Brooks .....	Brooks Instrument, LLC
Hastelloy .....	Haynes International
Teflon .....	E.I. DuPont de Nemours & Co.
Tri-Clover .....	Tri-Clover Inc.
Viton .....	DuPont Performance Elastomers



**Brooks Instrument**  
 407 West Vine Street  
 P.O. Box 903  
 Hatfield, PA 19440-0903 USA  
 T (215) 362-3700  
 F (215) 362-3745  
 E-Mail [BrooksAm@BrooksInstrument.com](mailto:BrooksAm@BrooksInstrument.com)  
[www.BrooksInstrument.com](http://www.BrooksInstrument.com)

**Brooks Instrument**  
 Neonstraat 3  
 6718 WX Ede, Netherlands  
 T 31-318-549-300  
 F 31-318-549-309  
 E-Mail [BrooksEu@BrooksInstrument.com](mailto:BrooksEu@BrooksInstrument.com)

**Brooks Instrument**  
 1-4-4 Kitasuna Koto-Ku  
 Tokyo, 136-0073 Japan  
 T 011-81-3-5633-7100  
 F 011-81-3-5633-7101  
 E-Mail [BrooksAs@BrooksInstrument.com](mailto:BrooksAs@BrooksInstrument.com)

