

Supplemental Manual for Brooks® Model MT3809G Metal Tube, Variable Area Flowmeter with Foundation™ Fieldbus Communications



Essential Instructions Read before proceeding!

Brooks Instrument designs, manufactures and tests its products to meet many national and international standards. These products must be properly installed, operated and maintained to ensure they continue to operate within their normal specifications. The following instructions must be adhered to and integrated into your safety program when installing, operating and maintaining Brooks Instrument products.

- To ensure proper performance, use qualified personnel to install, operate, update, program and maintain the product.
- Read all instructions prior to installing, operating and servicing the product. If this instruction manual is not the correct manual, please see back cover for local sales office contact information. Save this instruction manual for future reference.

▲ WARNING: Do not operate this instrument in excess of the specifications listed in the Instruction and Operation Manual. Failure to heed this warning can result in serious personal injury and / or damage to the equipment.

- If you do not understand any of the instructions, contact your Brooks Instrument representative for clarification.
- Follow all warnings, cautions and instructions marked on and supplied with the product.

▲ WARNING: Prior to installation ensure this instrument has the required approval ratings to meet local and national codes. Failure to heed this warning can result in serious personal injury and / or damage to the equipment.

- Install your equipment as specified in the installation instructions of the appropriate instruction manual and per applicable local and national codes. Connect all products to the proper electrical and pressure sources.
- Operation: (1) Slowly initiate flow into the system. Open process valves slowly to avoid flow surges. (2) Check for leaks around the flow meter inlet and outlet connections. If no leaks are present, bring the system up to the operating pressure.
- Please make sure that the process line pressure is removed prior to service. When replacement parts are required, ensure that qualified people use replacement parts specified by Brooks Instrument. Unauthorized parts and procedures can affect the product's performance and place the safe operation of your process at risk. Look-alike substitutions may result in fire, electrical hazards or improper operation.
- Ensure that all equipment doors are closed and protective covers are in place to prevent electrical shock and personal injury, except when maintenance is being performed by qualified persons.

▲ WARNING: For liquid flow devices, if the inlet and outlet valves adjacent to the devices are to be closed for any reason, the devices must be completely drained. Failure to do so may result in thermal expansion of the liquid that can rupture the device and may cause personal injury.

European Pressure Equipment Directive (PED)

All pressure equipment with an internal pressure greater than 0.5 bar (g) and a size larger than 25mm or 1" (inch) falls under the Pressure Equipment Directive (PED).

- The Specifications Section of this manual contains instructions related to the PED directive.
- Products described in this manual are in compliance with EN directive 2014/34/EU.
- All Brooks Instrument Flowmeters fall under fluid group 1.
- Products larger than 25mm or 1" (inch) are in compliance with PED category I, II or III.
- Products of 25mm or 1" (inch) or smaller are Sound Engineering Practice (SEP).

European Electromagnetic Compatibility (EMC)

The Brooks Instrument (electric/electronic) equipment bearing the CE mark has been successfully tested to the regulations of the Electro Magnetic Compatibility (EMC directive 2014/30/EU).

Special attention however is required when selecting the signal cable to be used with CE marked equipment.

Quality of the signal cable, cable glands and connectors:

Brooks Instrument supplies high quality cable(s) which meets the specifications for CE certification.

If you provide your own signal cable you should use a cable which is overall completely screened with a 100% shield.

"D" or "Circular" type connectors used should be shielded with a metal shield. If applicable, metal cable glands must be used providing cable screen clamping.

The cable screen should be connected to the metal shell or gland and shielded at both ends over 360 Degrees.

The shield should be terminated to an earth ground.

Card Edge Connectors are standard non-metallic. The cables used must be screened with 100% shield to comply with CE certification.

The shield should be terminated to an earth ground.

For pin configuration : Please refer to the enclosed Instruction Manual.

ESD (Electrostatic Discharge)

▲ CAUTION: This instrument contains electronic components that are susceptible to damage by static electricity. Proper handling procedures must be observed during the removal, installation or other handling of internal circuit boards or devices.

Handling Procedure:

1. Power to unit must be removed.
2. Personnel must be grounded, via a wrist strap or other safe, suitable means before any printed circuit card or other internal device is installed, removed or adjusted.
3. Printed circuit cards must be transported in a conductive container. Boards must not be removed from protective enclosure until immediately before installation. Removed boards must immediately be placed in protective container for transport, storage or return to factory.

Comments

This instrument is not unique in its content of ESD (electrostatic discharge) sensitive components. Most modern electronic designs contain components that utilize metal oxide technology (NMOS, SMOS, etc.). Experience has proven that even small amounts of static electricity can damage or destroy these devices. Damaged components, even though they appear to function properly, exhibit early failure.

Installation and Operation Manual

X-DPT-FF-MT3809G-Alarms-eng

Part Number: 541B218AAG

December, 2017

Model MT3809G FOUNDATION™ Fieldbus

Dear Customer,

We appreciate this opportunity to service your flow measurement and control requirements with an integrated system from Brooks Instrument. Every day, flow customers all over the world turn to Brooks Instrument for solutions to their gas and liquid low-flow applications. Brooks provides an array of flow measurement and control products for various industries from biopharmaceuticals, oil and gas, fuel cell research and chemicals, to medical devices, analytical instrumentation, semiconductor manufacturing, and more.

The Brooks product you have just received is of the highest quality available, offering superior performance, reliability and value to the user. It is designed with the ever changing process conditions, accuracy requirements and hostile process environments in mind to provide you with a lifetime of dependable service.

We recommend that you read this manual in its entirety. Should you require any additional information concerning Brooks products and services, please contact your local Brooks Sales and Service Office listed on the back cover of this manual or visit www.BrooksInstrument.com

Yours sincerely,

Brooks Instrument

*THIS PAGE WAS
INTENTIONALLY
LEFT BLANK*

<u>Paragraph Number</u>	<u>Page Number</u>
Section 1 Introduction	
1.1 Introduction	1-1
Section 2 Installation	
2.1 Installation	2-1
Section 3 FOUNDATION Fieldbus Data	
3.1 FOUNDATION Fieldbus Data	3-1
Section 4 Getting Started	
4.1 Getting Started	4-1
Section 5 Transducer Blocks	
5. Transducer Blocks	5-1
5.1 Overview	5-1
5.2 Analog Input Transducer Block	5-1
Section 6 FOUNDATION Fieldbus Guidelines	
6 FOUNDATION Fieldbus Guidelines	6-1
6.1 General Network Installation Guidelines	6-1
6.2 FOUNDATION Fieldbus Interface Set-up Reference	6-5
Warranty, Local Sales/Service Contact Information	Back Cover
Table Number	Page Number
5-1 Parameters of the Analog Input Transducer Block	5-1

Model MT3809G FOUNDATION™ Fieldbus

*THIS PAGE WAS
INTENTIONALLY
LEFT BLANK*

1.1 Introduction

This document will provide an overview of FOUNDATION™ Fieldbus software interface for Brooks Instrument Variable Area Flowmeters model MT3809G with FOUNDATION™ Fieldbus transmitter. This document describes the function and transducer blocks along with grids that show the available parameters.

This document is a supplement to the Metal Tube Variable Area Flowmeters Installation and Operation Manual X-VA-MT3809G-MT3810G-eng.

Model MT3809G FOUNDATION™ Fieldbus

*THIS PAGE WAS
INTENTIONALLY
LEFT BLANK*

2.1 Installation

Carefully read and follow the instructions for installation and operation given in the Metal Tube Variable Area Flowmeters Installation and Operation Manual
X-VA-MT3809G-MT3810G-eng.

*THIS PAGE WAS
INTENTIONALLY
LEFT BLANK*

3.1 FOUNDATION Fieldbus Data

Hardware Identification	
Manufacturer	Brooks Instrument
Model (Device Name)	MT38xx
Type of Device	Metal Tube Variable Area Flowmeter
Manufacturer ID	0x000246
Device Type ID	0x2000
Device Revision	041
Physical layer	H1
Quiescent Current Draw (mA)	12 mA
Data Blocks	
	1x Analog Input Function Block (1-AI)
	1x Integrator Function Block (1-IT)
	1x Analog Input Transducer Block (1-AITB)
	1x Resource Block (1-RB2)
	1x Diagnostics Transducer Block (1-DiagTB)
VCRs	Support up 24
ITK	ITK6
Registration	Registered by FieldComm

The 38xx flow meter contains two function blocks and three transducer blocks. The two function blocks are the analog input (AI) and the integrator block (IT). The three supported transducer blocks are the resource block, diagnostic block and the analog input transducer block.

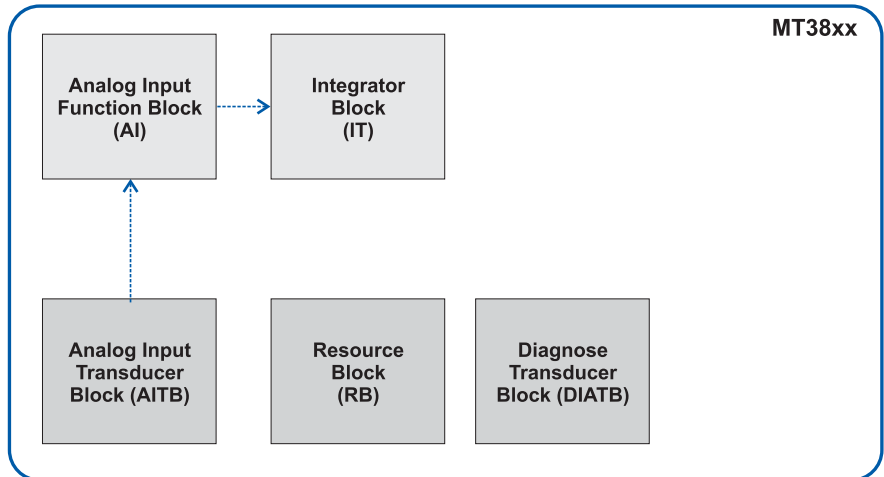

Model MT3809G FOUNDATION™ Fieldbus

*THIS PAGE WAS
INTENTIONALLY
LEFT BLANK*

4.1 Getting Started

DD files are needed to operate the FOUNDATION Fieldbus.

The DD files for the MT38xx FF can be found on website www.fieldbus.org

Find the files under <End User Resources>, then <Registered Products>, choose for manufacturer <Brooks Instrument> and for Category <Flow>, then <Search>.

From here you can open either SLA Series, or MT38xx, and download the DD files.

The Analog Input (AI) and Intergrator (IT) blocks are standard FOUNDATION Fieldbus blocks and can be configured with any FOUNDATION Fieldbus configuration tool. Each of those blocks contain an output parameter that contains the output value of the block.

Configure Analog Input (AI) block for live measurement

In case of the AI block the output can be configured to use the primary value of the analog transducer block. The primary value is the default and used output for the flow value. To configure the output of the analog input such that the actual calculated flow is directly set to the output without any scaling, a minimum configuration of the following three parameters is necessary:

Parameter	Value	Remark
XD_SCALE.UNITS_INDEX	% (1342)	This is the only possible value for this parameter
CHANNEL	Flow Channel	This is the only possible value for this parameter
L_TYPE	Indirect	This is the only supported value, other values which can be chosen will return a write error condition

Once the configuration above is completed, the flow value will be written to the out parameter when the AI block is given an execution time on the bus. When an execution time is assigned for the AI block it is possible to set the mode of the AI block to AUTO and will the flow be written to the out parameter.

Integrator (IT) block

The IT block can be configured with a foundation fieldbus configuration application to connect the out parameter of the AI block to the in parameter of the IT block.

*THIS PAGE WAS
INTENTIONALLY
LEFT BLANK*

5 Transducer Blocks

5.1 Overview

The 38xx flow meter contains three transducer blocks which contain configuration and status information of the device:

- **Resource block:** The resource block is used for foundation fieldbus standard parameters. In this block it is possible to do a reset of the device, read status of the non-volatile memory, field diagnostics etc.

⚠ CAUTION

Do not reset device, unless a factory calibration is required. A reset of the device will result in a calibration data clear. Reset shall only be performed by authorized service personnel.

- **Diagnosis block:** The diagnosis block is an extra transducer block to monitor the fieldbus controller and the fieldbus itself. The diagnosis block can return information about bus errors, fatal errors etc.

- **Analog Input Transducer block:** The analog input transducer block is the transducer block which contains every parameter necessary to configure and control the flow meter. The parameters are divided in views for an organized list of the parameters. With those parameters the calibration, the totalizer, the output alarms and the other functions can be set and viewed.

The parameter structure of the Analog Input Transducer block is specifically defined for the Brooks Instrument VA Flowmeter. A detailed description of the block follows in the next section.

5.2 Analog Input Transducer Block

The following table lists and describes the parameters of the Analog Input Transducer Block.

Table 5-1 Parameters of the Analog Input Transducer Block

Index	Sub Index	Parameter Name	Description	Data Type	Valid Values	Initialized Value	Read only or Read/Write
1		ST_REV	Revision number. This number will be incremented when a static parameter is changed	U16	0 to 65535	0	Read only
2		TAG_DESC	User description tag of this block	Oct	0 to 255 Max 32 digits	blanks	Read/Write
3		STRATEGY	Can be used to identify grouping of blocks. This value is not used by the block itself	U16	0 to 65535	0	Read/Write
4		ALERT_KEY	Identification number of the plant unit. This information may be used in the host for sorting alarms etc.	U8	0 to 255	0	Read/Write
5		MODE_BLK	The actual, target, permitted and normal modes for this block				
5	1	MODE_BLK.TARGET	The target mode for this block	Bit String	<ul style="list-style-type: none"> • None • OOS • Auto • Cas • RCas • ROut 	Auto	Read/Write
5	2	MODE_BLK.ACTUAL	This is the current mode of this block	Bit String	<ul style="list-style-type: none"> • None • OOS • Auto 	Auto	Read
5	3	MODE_BLK.PERMITTED	Contains the modes which are allowed for this block	Bit String	<ul style="list-style-type: none"> • OOS • Auto 	Auto OOS	Read/Write

Table continued on next page.

Model MT3809G FOUNDATION™ Fieldbus

Table 5-1 Parameters of the Analog Input Transducer Block (continued)

Index	Sub Index	Parameter Name	Description	Data Type	Valid Values	Initialized Value	Read only or Read/Write
5	4	MODE_BLK.NORMAL	Setting for which mode should be used when operated with normal conditions	Bit String	• None • OOS • Auto	Auto	Read/Write
6		BLOCK_ERR	Error status of this block	Bit String	• None • Out of Service	None	Read
7		UPDATE_EVT	On a change in the static data this alert is generated				
7	1	UPDATE_EVT.UNACKNOWLEDGED	Interface to acknowledge this update alert	U8	(0) Uninitialized (1) Acknowledged (2) Unacknowledged	(0) Uninitialized	Read/Write
7	2	UPDATE_EVT.UPDATE_STATE	Indication if the alert has been reported	U8	(0) Uninitialized (1) Reported (2) Not Reported	(0) Uninitialized	Read
7	3	UPDATE_EVT.TIMESTAMP	The time stamp when the alert is generated	TM	MM/DD/YY HH:MM:SS	0	Read
7	4	UPDATE_EVT.STATIC_REVISION	The static revision when the alert was generated.	U16	0 to 65535	0	Read
7	5	UPDATE_EVT.RELATIVE_INDEX	The index of the static parameter whose causes this alert to be generated	U16	0 to 65535	0	Read
8		BLOCK_ALARM	The block alarm can generate an alarm if a block error occurs				
8	1	BLOCK_ALARM.UNACKNOWLEDGED	Interface to acknowledge this block alarm	U8	(0) Uninitialized (1) Acknowledged (2) Unacknowledged	(0) Uninitialized	Read/Write
8	2	BLOCK_ALARM.ALARM_STATE	Indication if alarm is active or cleared and reported	U8	Uninitialized Clear-Reported Clear-Not Reported Active-Reported Active-Not Reported	Uninitialized	Read
8	3	BLOCK_ALARM.TIMESTAMP	The time stamp when the alarm is generated	TM	MM/DD/YY HH:MM:SS	0	Read
8	4	BLOCK_ALARM.SUBCODE	The sub code which causes the block alarm	U8	Other OutOfService	Other	Read
8	5	BLOCK_ALARM.VALUE	The value of the parameter associated with this alarm	U8	0 to 255	0	Read
9		TRANSDUCER_DIRECTORY	A directory that specifies the number of the data collections in the transducer block	U16	0	0	Read
10		TRANSDUCER_TYPE	Identifies the transducer error that follows	U16	Other (65535)	Other	Read
11		XD_ERROR	Transducer error code	U8	Unspecified error General error (0) No error	0	Read
12		COLLECTION_DIRECTORY	A directory that specifies the number of the data collections in each transducer within a transducer block	U8	0	0	Read
13		PRIMARY_VALUE	The measure flow value and status.				
13	1	PRIMARY_VALUE.STATUS	The status of the primary value	U8	Bad Good NonCascade	Good Non Cascade	Read
13	2	PRIMARY_VALUE.VALUE	The value of the primary value	Float		0.0	Read
14		FLOW_RATE_UOM	Units of measurement of the flow rate given in the primary value	U16	Supported UOMs	Calibrated value	Read/Write
15		SW_REV	Software version of the application	Visible String	x.x.x where the x represents the version		Read
16		HW_REV	Hardware revision of the transmitter	Visible String	x.x.x where the x represents the version		Read
17		BROOKS_PASSWORD	Password protection for manufacture settings	Visible string	Brooks password	*****	Read/Write
18		MESSAGE	Extra message field for indicating the transmitter. This value is not processed	Visible String	ASCII Max 24 chars	Blank	Read/Write
19		TAG_NAME	Extra tag name for the device. This value is not processed	Visible String	ASCII Max 16 chars	Calibrated value	Read/Write
20		DESCRIPTOR	Extra descriptor field for the device. This value is not processed	Visible String	ASCII Max 17 chars	Blank	Read/Write
21		DEV_DATE	Date of calibration	Visible String	DD/MM/YY	Calibrated value	Read/Write
22		AO_FILTER	The analog filter values used for the flow calculation	Float	0.00 to 10.00	Calibrated value	Read/Write
23		FIN_ASSY_NUM	Final assembly number	U32	0 to 4294967296	Calibrated value	Read/Write
24	0..9	CALIB_POSITION	10 position array with calibrated float positions.	Float		Calibrated values	Read/Write
25	0..9	CALIB_FLOW_RATE	10 position array with calibrated flow rates according to the scale	Float		Calibrated values	Read/Write
26		LFCUTOFF	Low flow cut off value. Every value below this flow will be cut off to zero	Float	0.00 to 99999.9	0	Read/Write
27		DENSITY	Density uom and value used for the calculation				
27	1	DENSITY.UOM		U16	Reserved, do not use	0	Read/Write
27	2	DENSITY.VALUE		Float	Reserved, do not use	1.0	Read/Write
28		PRESSURE	Pressure uom and value used for the calculation				
28	1	PRESSURE.UOM		U16	Reserved, do not use	0	Read/Write
28	2	PRESSURE.VALUE		Float	Reserved. Do not use	0.0	Read/Write

Table 5-1 Parameters of the Analog Input Transducer Block (continued)

Index	Sub Index	Parameter Name	Description	Data Type	Valid Values	Initialized Value	Read only or Read/Write
29		MODEL_NUMBER	Model number of the assembled device		ASCII Max 20 chars	Calibrated Value	Read/Write
30		RES_TOTALIZER	A resettable totalizer independent of the function block				
30	1	RES_TOTALIZER.UOM	The units of measurement which the totalizer will use	U16	Supported UOMs	Gallon	Read/Write
30	2	RES_TOTALIZER.VALUE	The value of the resettable totalizer	Float		0.0	Read
31		RESET_RES_TOTALIZER	Used to reset the resettable totalizer	U8	(0) Idle (1) Reset	Idle	Read/Write
32		RES_TOT_DIG_DEC	Setting of max number of integer digits before automatic reset	U8	0 to 7	2	Read/Write
33		INV_TOTALIZER	A inventory totalizer which is independent of the function block				
33	1	INV_TOTALIZER.UOM	The units of measurement used for the totalizer	U16	Supported UOMs	Gallon	Read/Write
33	2	INV_TOTALIZER.VALUE	The value of the inventory totalizer	Float		0.0	Read
34		INV_TOT_DIG_DEC	Setting of max number of integer digits before automatic reset	U8	0 to 7	2	Read/Write
35		LO_FLOW	The settings for the low flow alarm with a dedicated alarm output on the transmitter				
35	1	LO_FLOW.ALARM_EN	Enables or disables the low flow alarm	U8	(0) Disabled (1) Enabled	(1) Enabled	Read/Write
35	2	LO_FLOW.ALARM_TYPE	A non latching alarm type will clear the alarm if the flow is above the low flow setting	U8	(0) Non-latched (1) Latched	(0) Non-latched	Read/Write
35	3	LO_FLOW.ALARM_LIMIT	The value which will cause the alarm if the flow value falls below this value	Float		9.99	Read/Write
35	4	LO_FLOW.ALARM_LIMIT_DELAY	The time a flow needs to be below the setting before the alarm is triggered	U8	0 to 255 Seconds	0	Read/Write
36		HIGH_FLOW	The settings for the high flow alarm with a dedicated alarm output on the transmitter				
36	1	HIGH_FLOW.ALARM_EN	Enables or disables the high flow alarm	U8	(0) Disabled (1) Enabled	(1) Enabled	Read/Write
36	2	HIGH_FLOW.ALARM_TYPE	A non latching alarm type will clear the alarm if the flow is below the high flow setting	U8	(0) Non-latched (1) Latched	(0) Non-latched	Read/Write
36	3	HIGH_FLOW.ALARM_LIMIT	The value which will cause the alarm if the flow value rises above this value	Float		90.0	Read/Write
36	4	HIGH_FLOW.ALARM_LIMIT_DELAY	The time a flow needs to be above the setting before the alarm is triggered	U8	0 to 255	0	Read/Write
37		PULS_OUT_CFG	This alarm is used if the configuration for the pulse output is wrong. This alarm has no physical output on the transmitter				
37	1	PULS_OUT_CFG.ENABLE	Enables or disables the pulse output configuration alarm	U8	(0) Disabled (1) Enabled	(1) Enabled	Read/Write
37	2	PULS_OUT_CFG.TYPE	A non latching alarm type will clear the alarm if configuration is corrected.	U8	(0) Non-latched (1) Latched	(1)Latched	Read/Write
38		PULS_OUT_OVERRUN	This alarm is used if the pulse output cannot keep up with the pulse algorithm				
38	1	PULS_OUT_OVERRUN.ENABLE	Enables or disables the pulse output overrun alarm	U8	(0) Disabled (1) Enabled	(0) Disabled	Read/Write
38	2	PULS_OUT_OVERRUN.TYPE	A non latching alarm type will clear the alarm if overrun is solved	U8	(0) Non-latched (1) Latched	(0) Non-latched	Read/Write
39		DIAG	This alarm is used to inform if a software error has occurred				
39	1	DIAG.ENABLE	Enables or disables the diagnostic alarm	U8	(0) Disabled (1) Enabled	(1) Enabled	Read/Write
39	2	DIAG.TYPE	A non latching alarm type will clear the alarm if the problem is solved.	U8	(0) Non-latched (1) Latched	(1)Latched	Read/Write
40		DB_INIT	This alarm is reserved for future use				
40	1	DB_INIT.ENABLE	This alarm is reserved for future use	U8	(0) Disabled (1) Enabled	(1) Enabled	Read/Write
40	2	DB_INIT.TYPE	This alarm is reserved for future use	U8	(0) Non-latched (1) Latched	(1)Latched	Read/Write
41		POWER	This alarm is reserved for future use				
41	1	POWER.ENABLE	This alarm is reserved for future use	U8	(0) Disabled (1) Enabled	(1) Enabled	Read/Write
41	2	POWER.TYPE	This alarm is reserved for future use	U8	(0) Non-latched (1) Latched	(1)Latched	Read/Write
42		BROOKS_SERIAL_NUMBER	The serial number assigned to the device	Visible String	ASCII Max 32 chars	Calibrated value	Read/Write
43		CURRENT_ALARM_STATUS	Bitwise representation of the alarms.	U32	(0) No Alarm (1) Diag_Alarm (2) Reserved (4) Reserved (8) Flow_High_Alarm (16) Flow_Low_Alarm (32) Pulse_Config_Alarm (64)Pulse Overrun Alarm	0	Read
44		ACTIVE_DIAG_STATUS	Bitwise representation of the cause of the diagnostic alarm	U32	(0) Good (1) Ram fail (2) Flash fail (4) Database fail (8) Float position fail (16) Calibration fail	0	Read
45		RESET_ALARM	Function to reset the alarms which are shown active in current alarm status	U8	(0) Idle (1) Reset	(0) Idle	Read/Write
46		PULSE_OUTPUT	Settings to set the pulse output on the transmitter				

Table continued on next page.

Table 5-1 Parameters of the Analog Input Transducer Block (continued)

Index	Sub Index	Parameter Name	Description	Data Type	Valid Values	Initialized Value	Read only or Read/Write
46	1	PULSE_OUTPUT.UOM	Unit of measurement used to generate the pulses	U16	Supported UOMS	Gallon	Read/Write
46	2	PULSE_OUTPUT.SCALER	The scale value scales the number of pulses according to het flow	Float	0.1 to 10.0	1.0	Read/Write
46	3	PULSE_OUTPUT.PULSE_WIDTH	The pulse width of each pulse on the pulse output	Float	0.00 to 50.0	50.0	Read/Write
47		WEIGHTS_MEASURES_CALIB	Information about the calibration	U32		0	Read
48		WEIGHTS_MEASURES_CONFIG	Information about the calibration	U32		0	Read
49		INFO_METER	The info meter contains information about the meter. The values which are a member of info_meter are not used in the process				
49	1	INFO_METER.FLOW_HI_LIMIT	The maximum limit of flow for this meter	Float		Calibrated Value	Read/Write
49	2	INFO_METER.FLOW_LO_LIMIT	The minimum of flow for this meter	Float		Calibrated Value	Read/Write
49	3	INFO_METER.TEMP_HI_LIMIT	The maximum temperature for this meter	Float		Calibrated Value	Read/Write
49	4	INFO_METER.TEMP_LO_LIMIT	The minimum temperature for this meter	Float		Calibrated Value	Read/Write
49	5	INFO_METER.MATL	The material of this meter	U8		Calibrated Value	Read/Write
49	6	INFO_METER.PRESSURE_HI_LIMIT	The maximum pressure for this meter	Float		Calibrated Value	Read/Write
49	7	INFO_METER.PRESSURE_LO_LIMIT	The minimum pressure for this meter	Float		Calibrated Value	Read/Write
49	8	INFO_METER.PRESSURE_DROP_LIMIT		Float		Calibrated Value	Read/Write
49	9	INFO_METER.FLANG_MATL		U8		Calibrated Value	Read/Write
49	10	INFO_METER.FLANGE_TYPE		U8		Calibrated Value	Read/Write
49	11	INFO_METER.FLOAT_MATL		U8		Calibrated Value	Read/Write
49	12	INFO_METER.FLOAT_TYPE		Visible String	ASCII Max 8 chars	Calibrated Value	Read/Write
49	13	INFO_METER.ORING_MATL		U8		Calibrated Value	Read/Write
49	14	INFO_METER.SIZE		U8		Calibrated Value	Read/Write
50		INFO_ACCESSORIES	Accessories attached to the meter	U8		Calibrated Value	Read/Write
51		MAGNET_ANGLE_ADJUSTED	The magnet angle of the measuring device after a zero adjust	Float		0.0	Read
52		MAGNET_ANGLE_ABSOLUTE	The magnet angle of the measuring device	Float		0.0	Read
53		MAGNET_ANGLE_OFFSET	The offset which is used to calculate the magnet adjusted angle from the absolute angle	Float		0.0	Read
54		VISCOSITY					
54	1	VISCOSITY.UOM	Units of measurements for the viscosity	U16	Supported UOMs	cP	Read/Write
54	2	VISCOSITY.VALUE		Float		1	Read/Write
55		Calibration	This group contains information about the calibration				
55	1	CALIB.FLUID		Visible String	Reserved, do not use		Read/Write
55	2	CALIB.TOOL		Visible String	Reserved, do not use		Read/Write
55	3	CALIB.ACC_CLASS		Visible String	Reserved, do not use		Read/Write
55	4	CALIB.NAME		Visible String	Reserved, do not use		Read/Write
55	5	CALIB.CALIB_DATA		Visible String	Reserved, do not use		Read/Write
55	6	CALIB.CALIB_FLOW_RATE_UOM		U16	Supported UOMs	Calibrated Value	Read/Write
55	7	CALIB.CALIB_TEMPERATURE_UOM		U16	Reserved, do not use		Read/Write
55	8	CALIB.CALIB_TEMPERATURE		Float	Reserved, do not use		Read/Write
55	9	CALIB.CALIB_PRESSURE_UOM		U16	Reserved, do not use		Read/Write
55	10	CALIB.CALIB_PRESSURE		Float	Reserved, do not use		Read/Write
55	11	CALIB.CALIB_DENS_UOM		U16	Reserved, do not use		Read/Write
55	12	CALIB.CALIB_DENSITY		Float	Reserved, do not use		Read/Write
55	13	CALIB.CALIB_VISCOSITY_UOM		U16	Reserved, do not use		Read/Write
55	14	CALIB.CALIB_VISCOSITY		Float	Reserved, do not use		Read/Write

Table continued on next page.

Table 5-1 Parameters of the Analog Input Transducer Block (continued)

Index	Sub Index	Parameter Name	Description	Data Type	Valid Values	Initialized Value	Read only or Read/Write
56		TEST	Test interface to test the alarm and pulse outputs. Testing is only possible when in testing mode				
56	1	TEST.CONTACT_OUTPUT	Select the first or second alarm output to test	U8	1 to 2	0	Read/Write
56	2	TEST.ACTION_STATUS	Set the output high or low	U8	0 to 1	0	Read/Write
56	3	TEST.TEST_PULSE_OUTPUT	Enable the pulse output test	U8	0 to 1	0	Read/Write
56	4	TEST.TEST_PULSE_FREQUENCY	Frequency which is used to test the pulse output	Float	0.00 to 100.0	0	Read/Write
56	5	TEST.TEST_PULSES_COUNT	Number of pulses before the test sequence is stopped	U32	1 to 100	0	Read/Write
56	6	TEST.ENTER_LEAVE	This parameter is used to enter or leave the test mode	U8	(0) Leave (1) Enter	(0) Leave	Read/Write
57		DISPLAY_SETTINGS	Change the settings to the attached display				
57	1	DISPLAY_SETTINGS.SCREEN_MODE	Enables the view of the flow and the two totalizers	Bit String	(0) None (1) Flow rate (2) Resettable totalizer (4) Inventory totalizer	(1) Flow Rate	Read/Write
57	2	DISPLAY_SETTINGS.FLOW_CYCLE_TIME	Time between the screen modes	U32		5	Read/Write
57	3	DISPLAY_SETTINGS.UOM_FULLSCALE	The unit of measurement full scale is use to get the best representation on the display	Float		100.0	Read/Write
58		SENSOR_ZERO	Sets the magnet sensor to zero for the calibration	U8	(0) Idle (1) Zero	(0) Idle	Read/Write

Model MT3809G FOUNDATION™ Fieldbus

*THIS PAGE WAS
INTENTIONALLY
LEFT BLANK*

6 FOUNDATION™ Fieldbus Guidelines

Source: FOUNDATION™ Fieldbus Application Guide - 31.25 kbit/s Wiring and Installation. Refer to the FOUNDATION™ Fieldbus fieldComm website in the end-user resources section for the complete set of application guides.

6.1 General Network Installation Guidelines

Building the network

Figure 6-1 shows how to make a fieldbus network from a wire pair. A terminator is added at the FFI end of the wire pair. Another terminator is added at the field device end of the wire pair. The FFI may have a built-in terminator so that you don't have to add one. Check the manufacturer's specifications to be sure.

Notice that neither wire is grounded. This is one of the absolute rules of fieldbus.

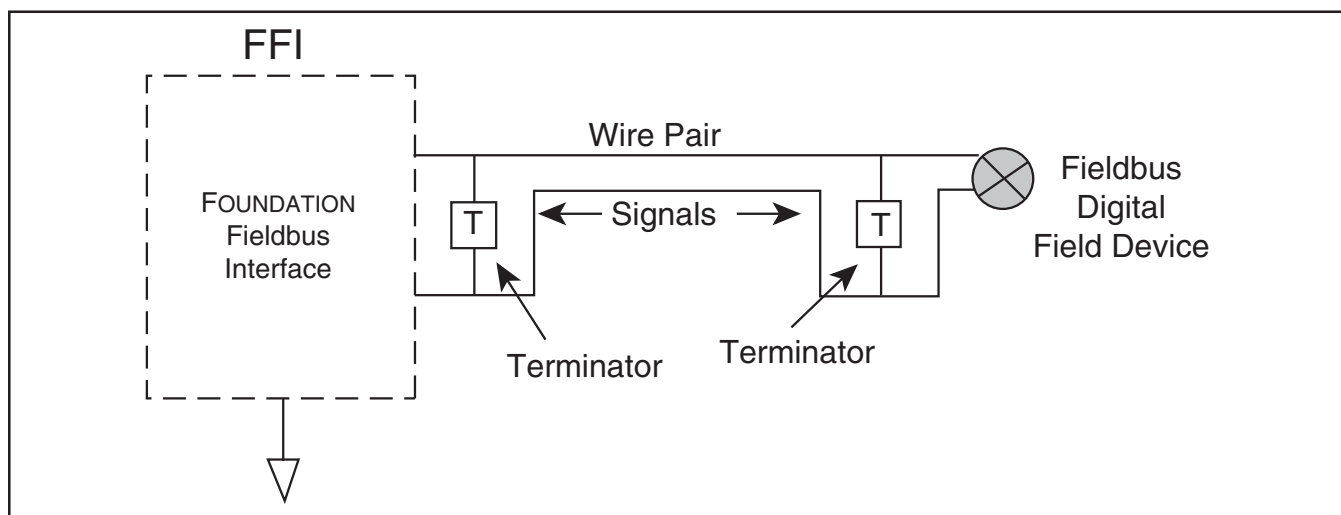

Figure 6-1 Simple Fieldbus Network

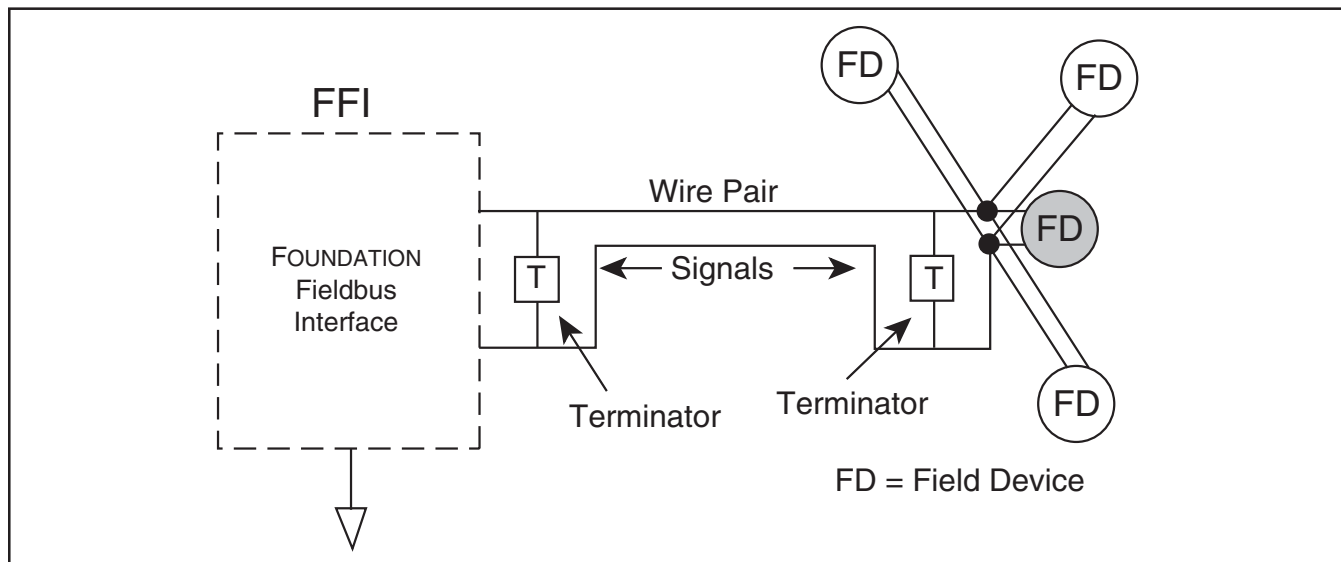

Figure 6-2 Fieldbus Network with Additional Devices Added

Model MT3809G FOUNDATION™ Fieldbus

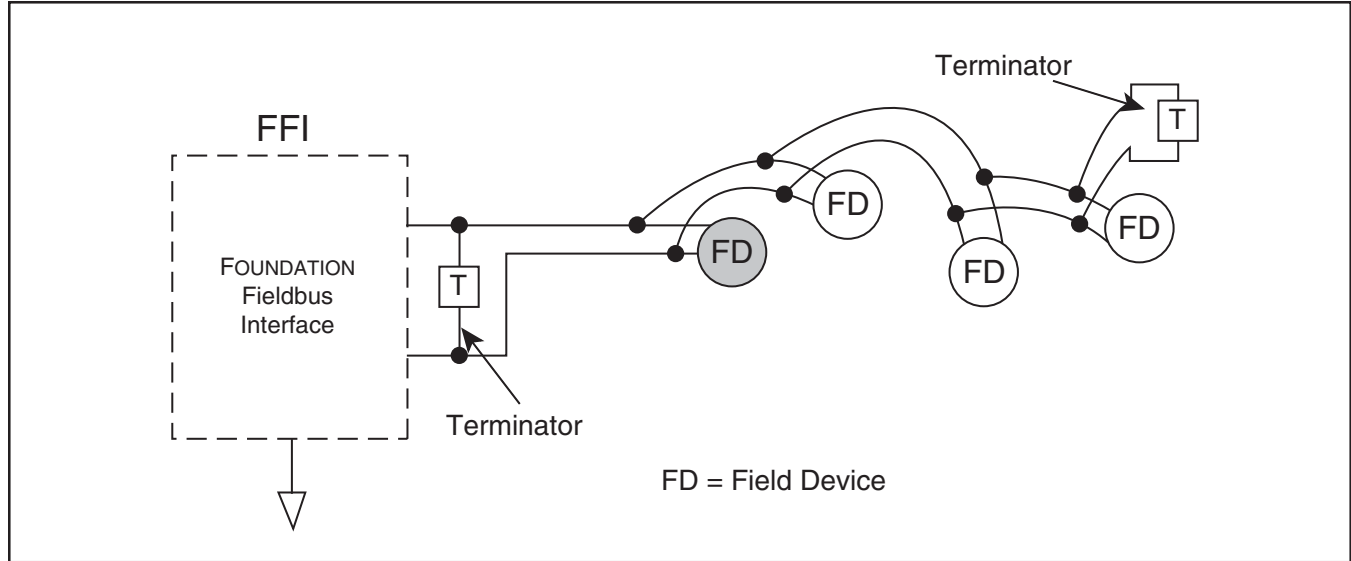

Figure 6-3 Fieldbus Network with Chained Devices

In Figure 6-2 more field devices have been added to the network of Figure 6-1. These new devices are simply connected in parallel with the first field device. The new devices are shown connected in a "star" fashion. However, they could also be chained from the first device as in Figure 6-3. All of the field devices and the FFI in Figures 6-2 and 6-3 are said to be "on the same network". A detailed figure showing the wiring of the junction of Figure 6-3 is given later.

You can see that new devices are always added in parallel to existing ones. Notice that the number of terminators in Figures 6-2 and 6-3 stays at two, regardless of what else we add to the network.

Speaking of terminators, how did we know where to put them?

To answer this we need to define a trunk. A trunk is the longest cable path between any two devices on the network. Once we've identified this stretch of cable, all other connections to it are called spurs.

The terminators should be placed at the ends of the trunk. We've assumed in Figures 6-2 and 6-3 that the FFI is further from the group of field devices (in cable length) than they are from each other.

This rule on location of terminators is one that can be bent. In Figure 6-2, for example, we haven't bothered to find the longest cable path. Instead, the terminator was placed at the junction of the group of field devices.

We've assumed that all of the field devices were about the same distance (in cable length) from the junction. Had one of them been a lot longer than the others, then we would move the terminator out to that device.

In Figure 6-3 we kept moving the terminator out to the farthest field device each time we added a device. However, if we are adding to an existing network and all of the field devices to be added are located on one short stretch of cable (100 m (328 ft.) or less), then the terminator could have been left in its original position at the first device.

Spurs: Shorter is Better!

Repeaters

What if you need a lot more than 1900 m (6232 ft.) of cable? You can do it by using a repeater. The repeater takes the place of one of the field devices. But it means you get to start fresh. You can add another 1900 m (6232 ft.) of cable, as illustrated in Figure 6-4. Notice that a new trunk has been created so that we have to add more terminators. The first trunk has

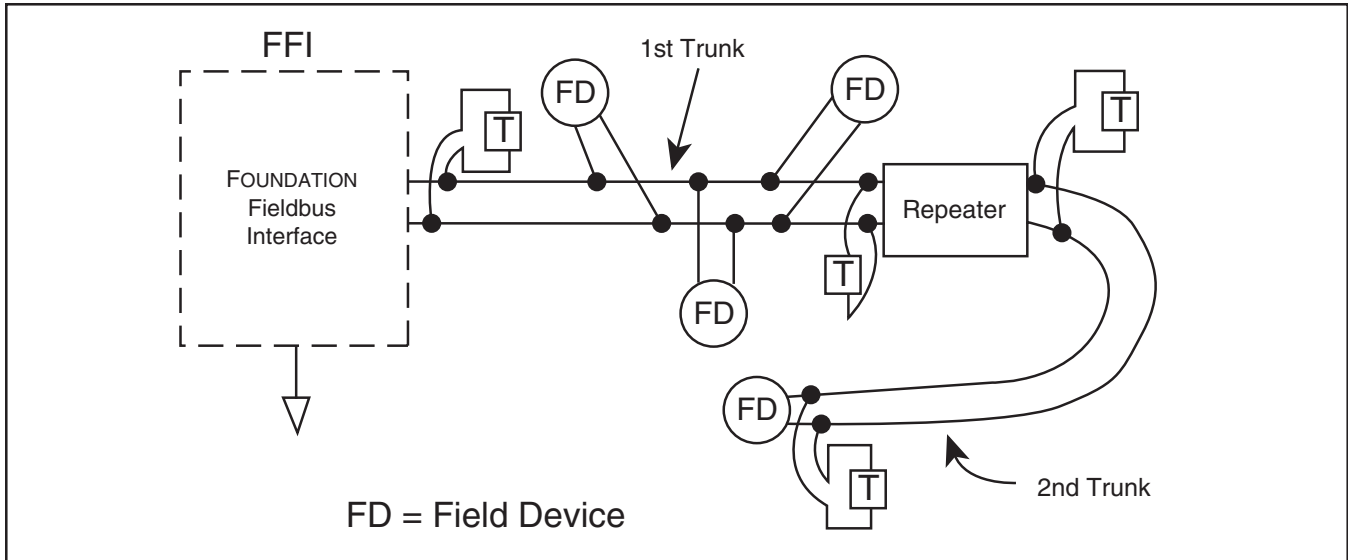

Figure 6-4 Adding a Repeater to the Fieldbus Network

four devices, one of them being the repeater. The second trunk has two devices, one of them being the repeater. You can use up to four repeaters in series between any two devices to get a total length of 9500 (31167.98 ft.) In addition to increasing the length of a network, repeaters can be used to increase the number of devices in a network beyond the limit of 32 on one segment. Using repeaters, the maximum number of devices in a network could be increased to 240.

Shielding (screening)

A fieldbus network can be built using only unshielded wire pairs. If these are placed in conduit or laid against a metal surface, there may be sufficient shielding that nothing further need be done. However, for best performance, fieldbus cables should be shielded. Common multi-conductor (multi-core) "instrument" cable can be used. This has one or more twisted pairs, an overall, metalized shield, and a shield wire.

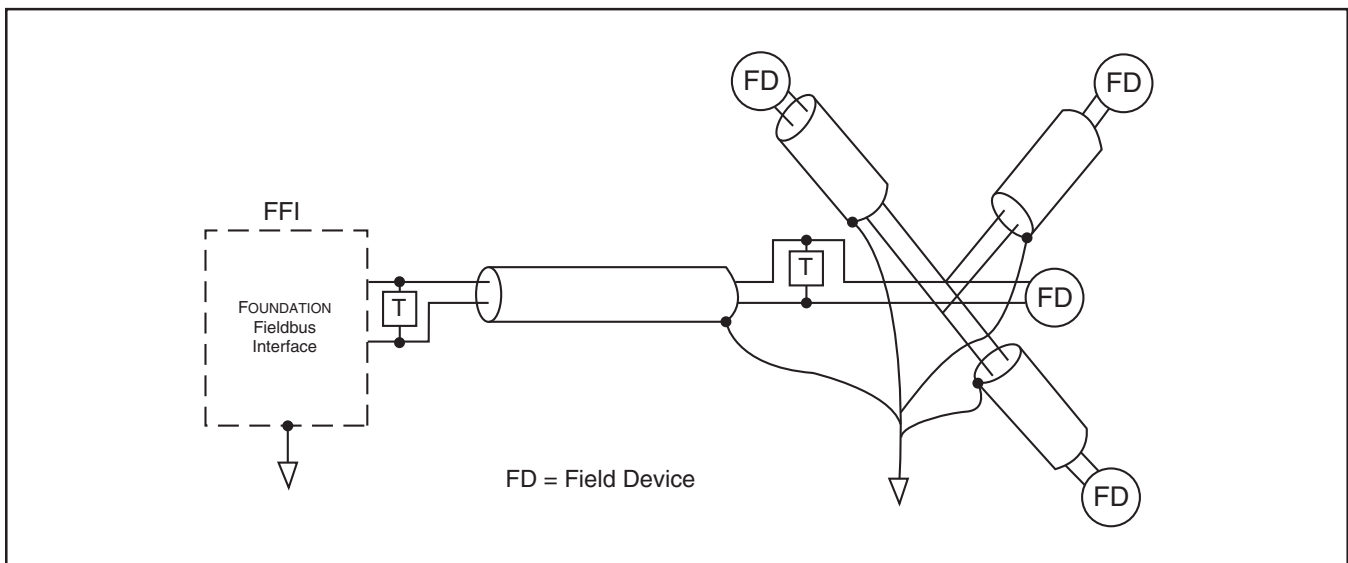

Figure 6-5 Use of Shielded Cable

6.2 FOUNDATION™ Fieldbus Interface Setup-Reference

Note: This interface setup is showing an example of how a device connection is made to a Softing FG-110 FF linking device using the Softing FF-CONF configuration tool.
In general, other types of FF interfaces will be operated in industrial processes, showing a different screen lay-out compared to the screens shown in this example.



Step 1: The 3809G FF device and the FG-110 FF Linking Device are both connected to the same Fieldbus Power Hub/FF segment network (Relcom F11). Launch FF-CONF tool, and open View <Network Livelist> (showing FF devices on the segment, currently only 1 H1 device).

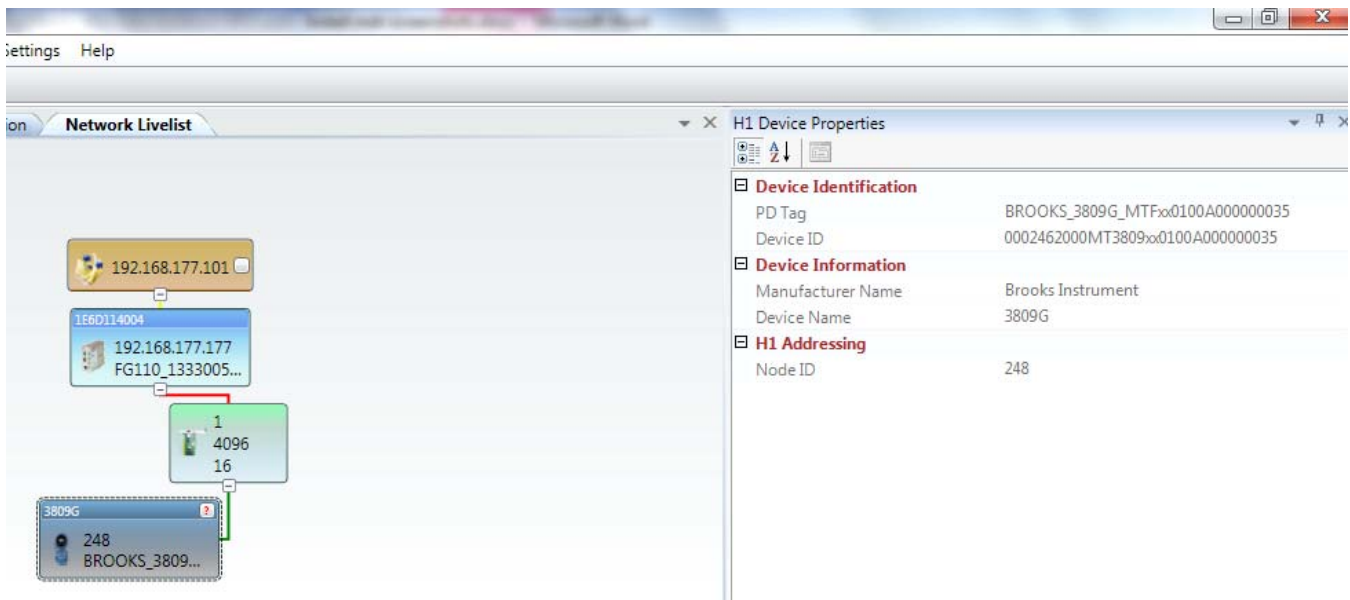

Step 2: Load device description files (DD/CFF files can be downloaded from www.fieldbus.org).

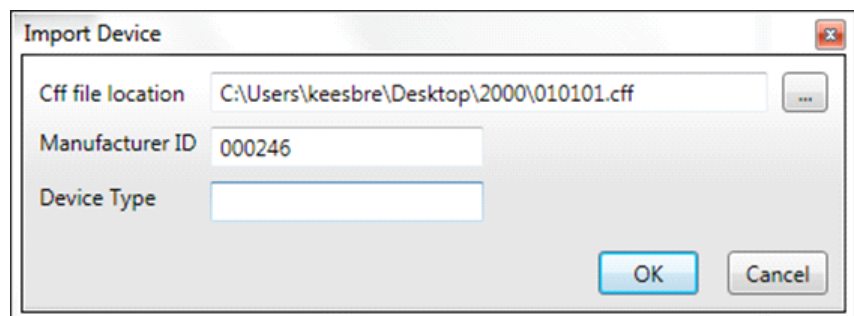

Model MT3809G FOUNDATION™ Fieldbus

Step 3: Assign appropriate PD Tag and Node ID as desired.

Default Assignment

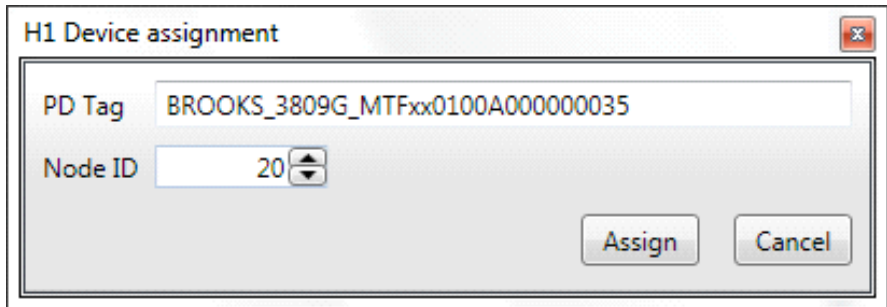

Assignment to be chosen (example)

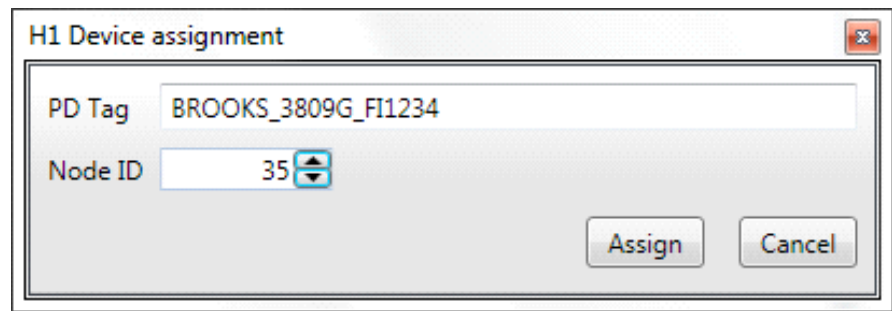

Result of assignment configuration.

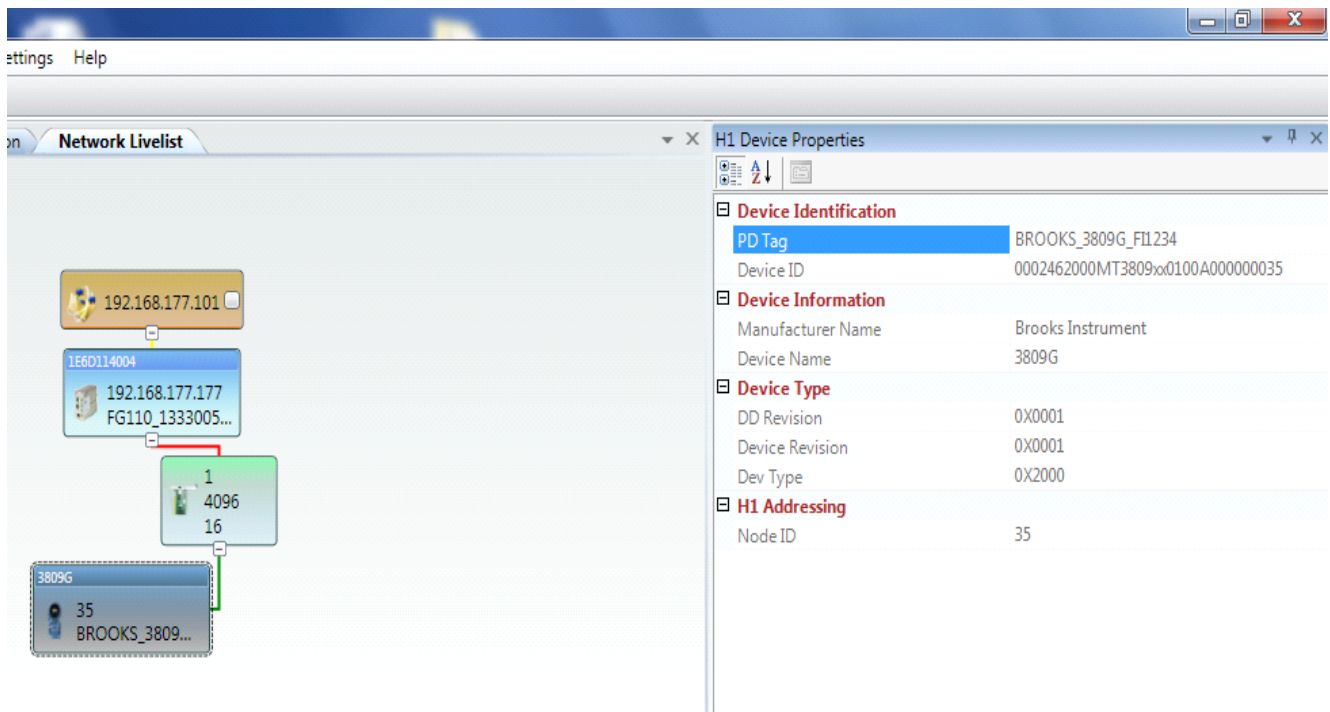

Step 4: Create New Project for Network Configuration

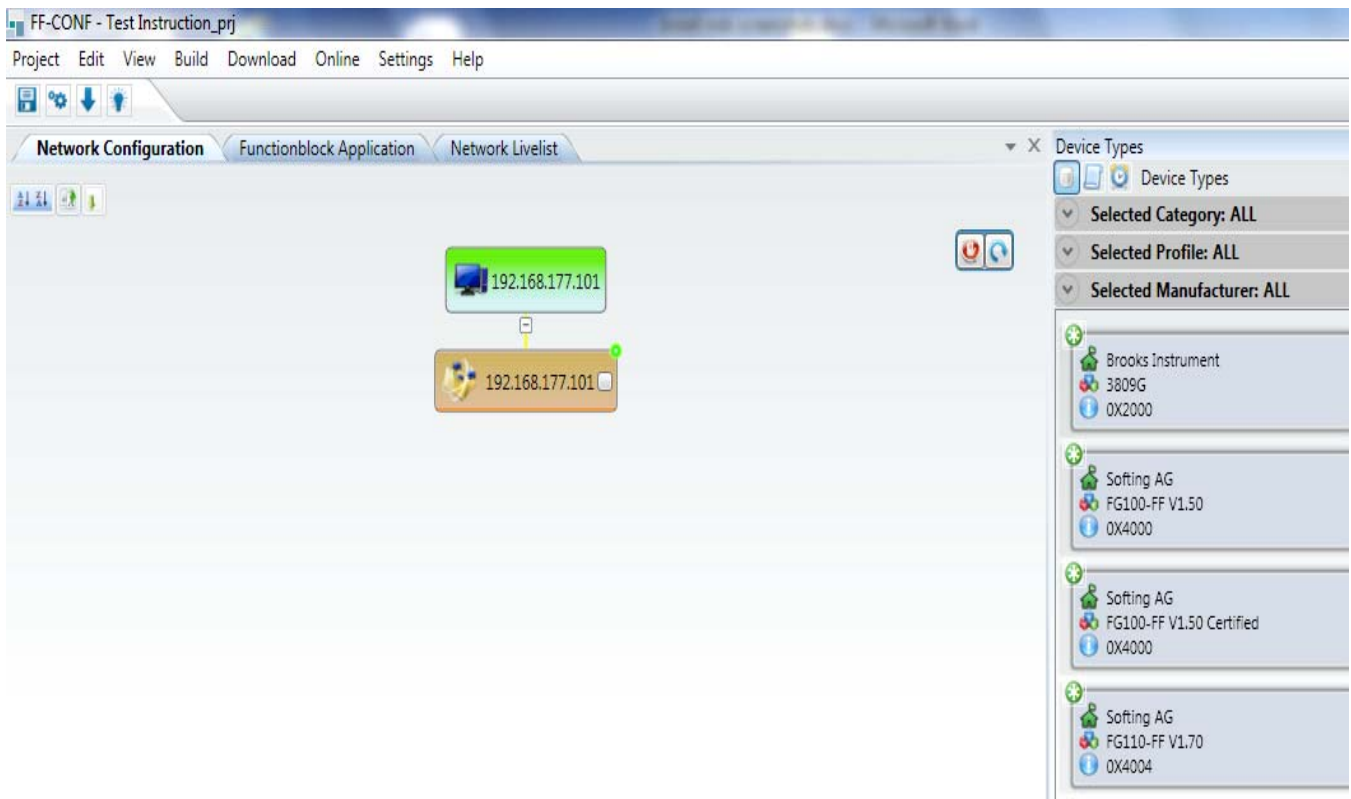
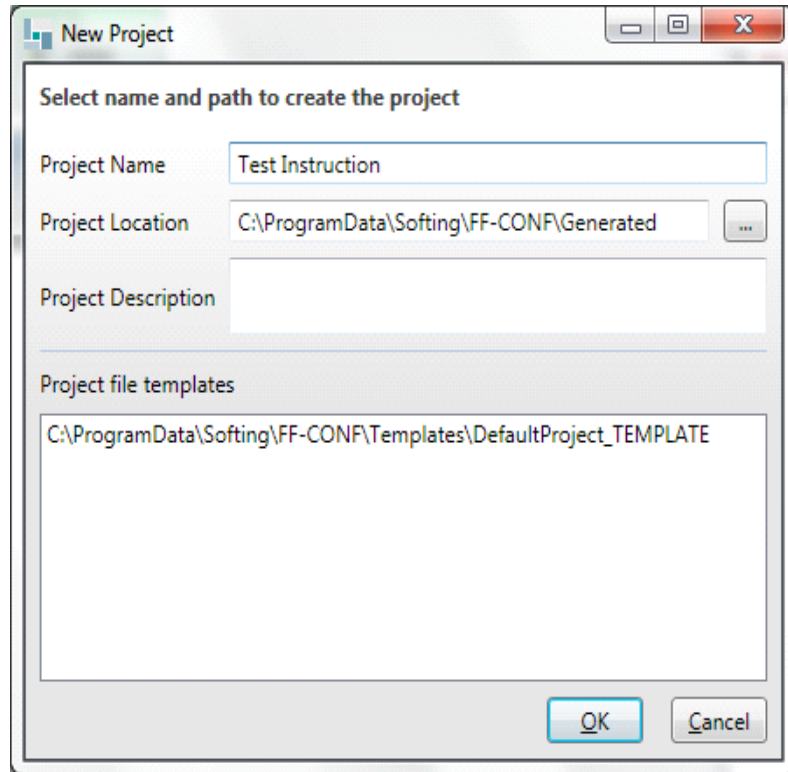

Default settings of MT3809G H1 device

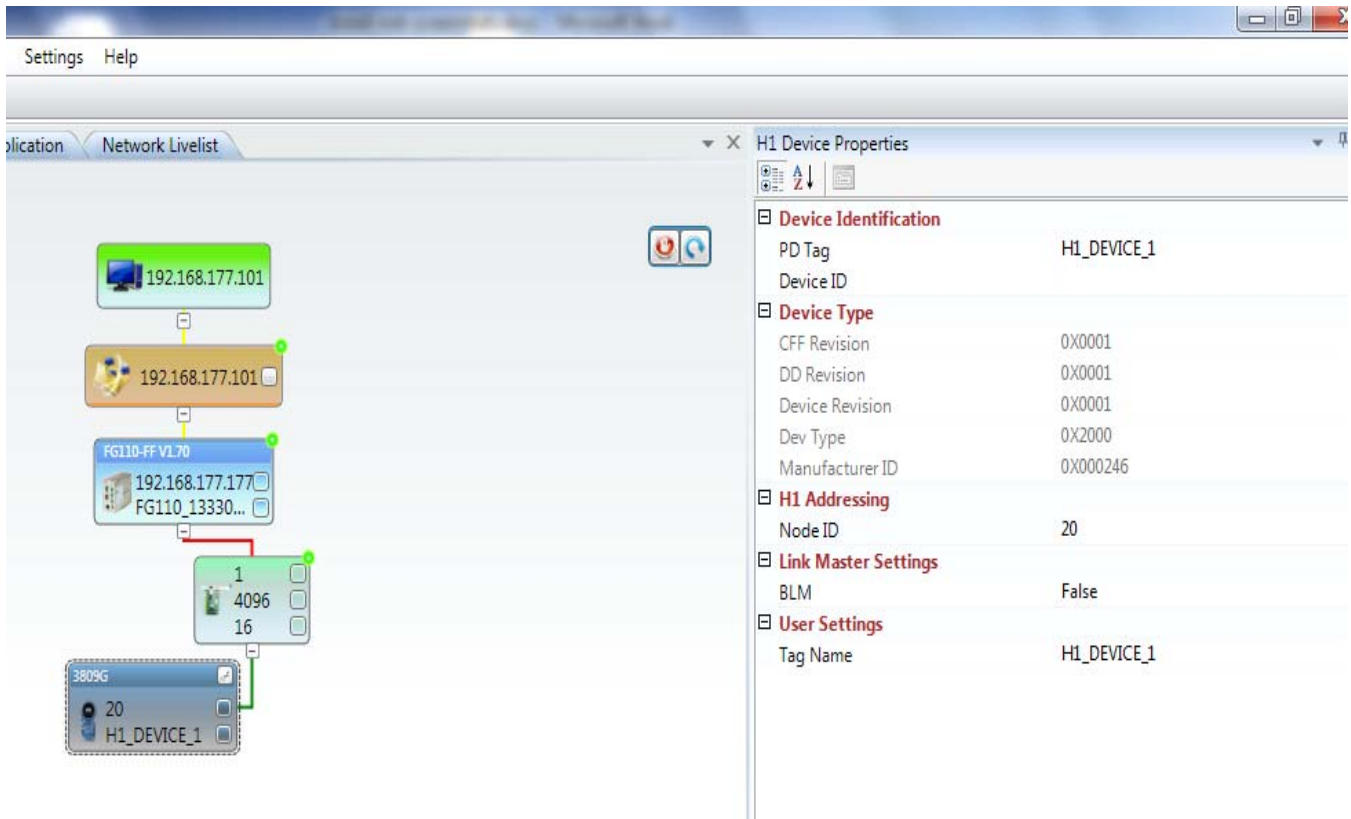

Step 7: Configure MT3809G device for appropriate Device ID, PD Tag and Node ID

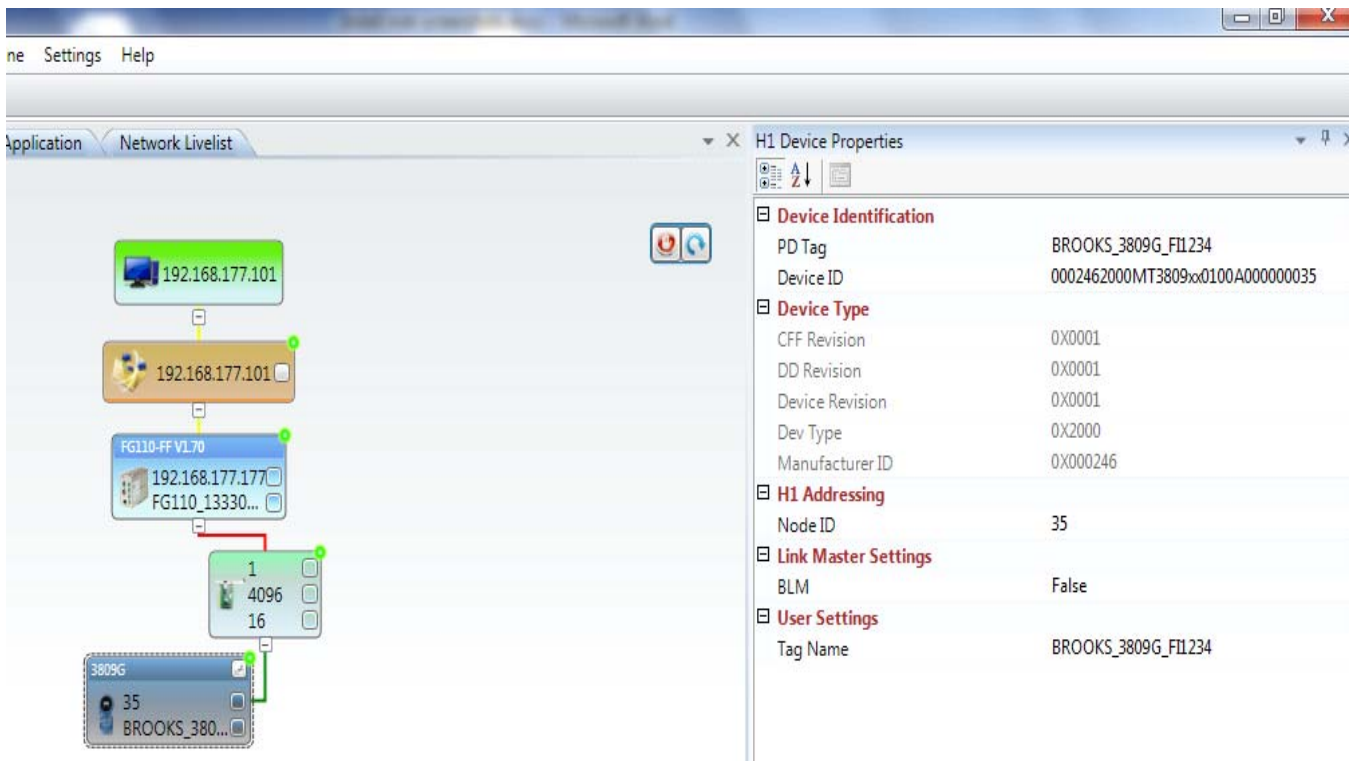

Model MT3809G FOUNDATION™ Fieldbus

Step 8: To operate the AI function block, a link must be created between AI block and IT block.

For this purpose, go to Functionblock Application tab.

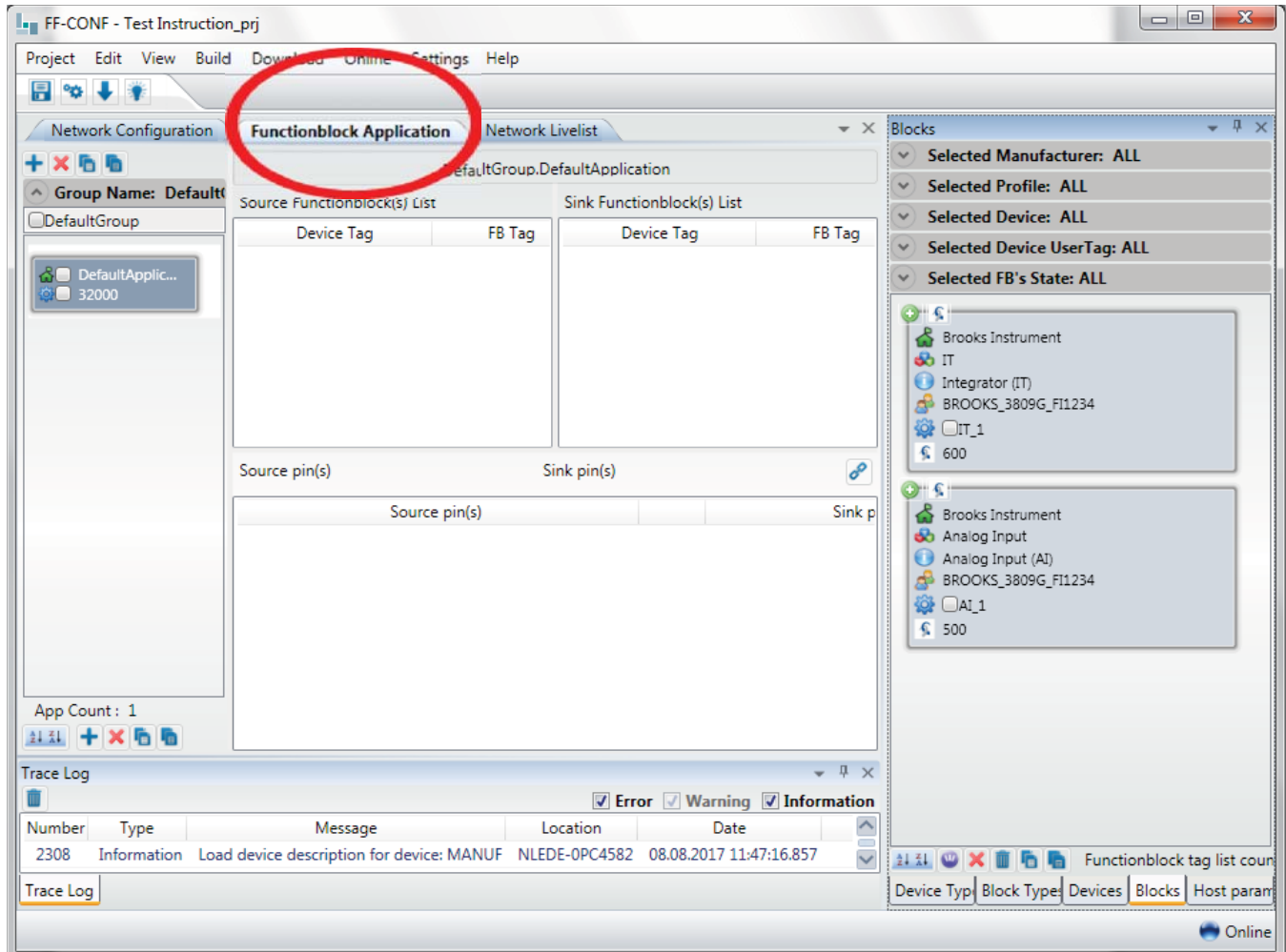

Step 9: Add AI block to Source Functionblock(s) List, and add IT block to Sink Functionblock(s) List

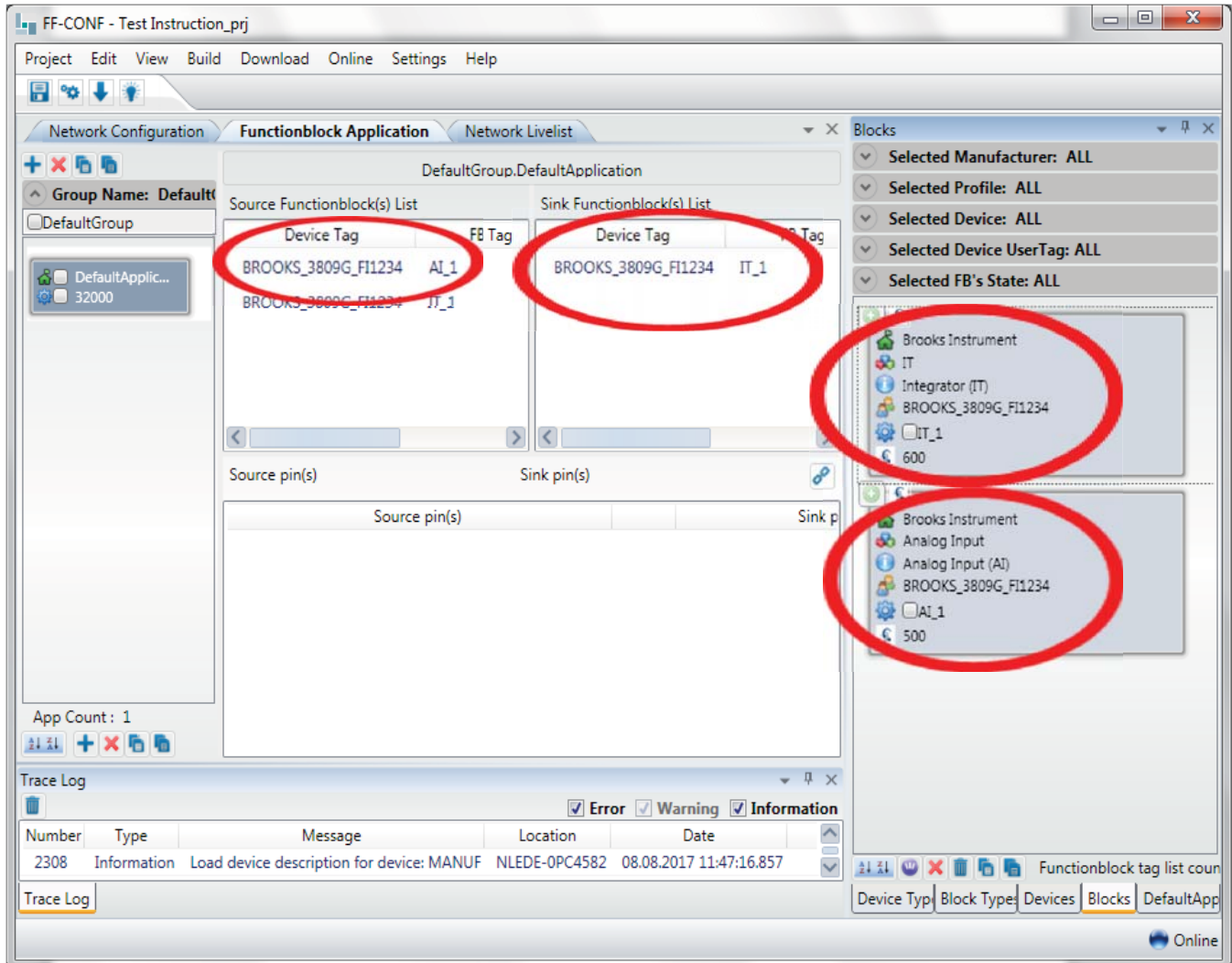

Model MT3809G FOUNDATION™ Fieldbus

Step 10: Add AI output to Source pin(s), and IT input to Sink pin(s):

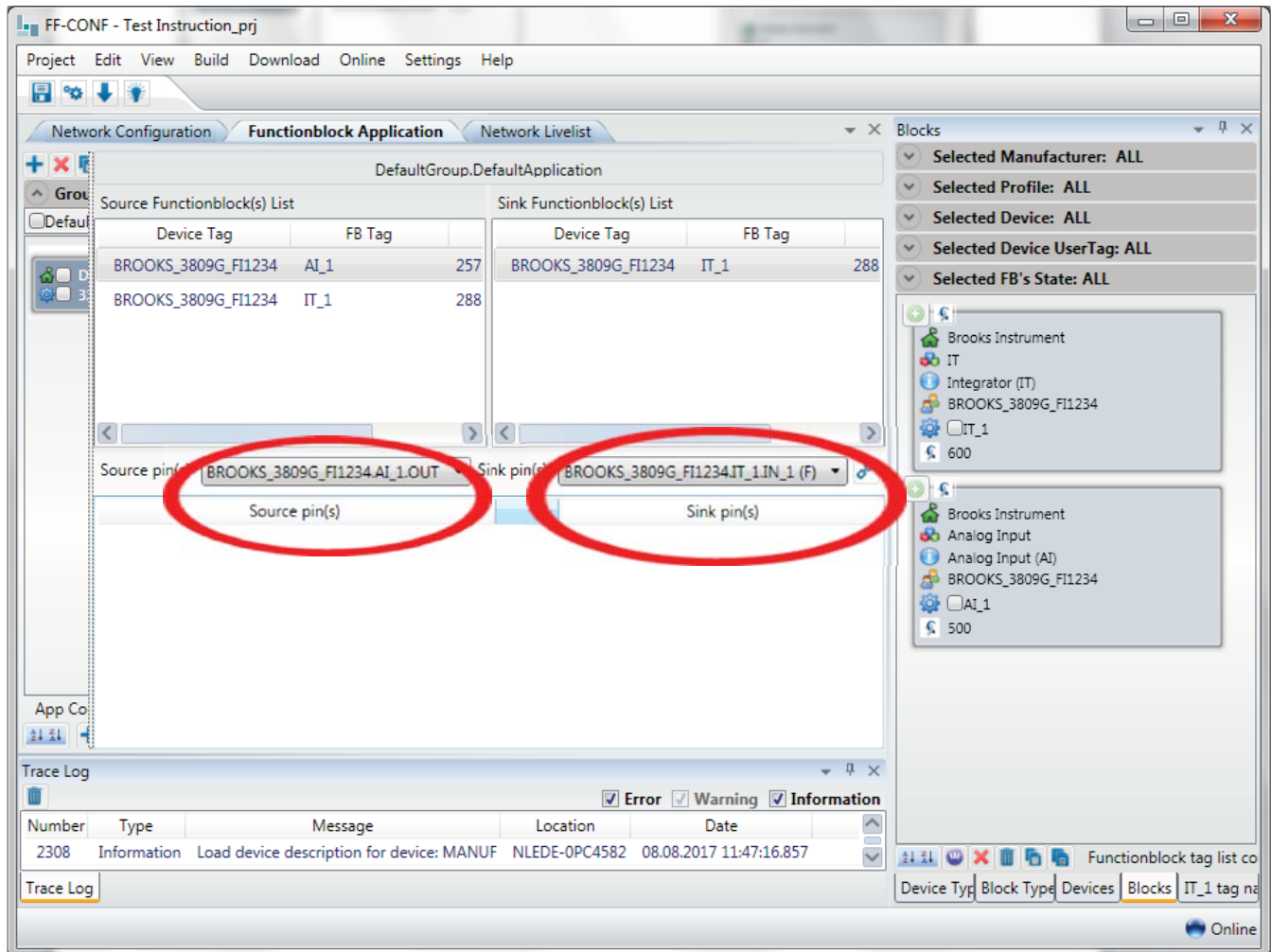

Step 11: Click connect icon button, choose Project <Save>, choose Download <Download project> , and AI output is now connected to IT input

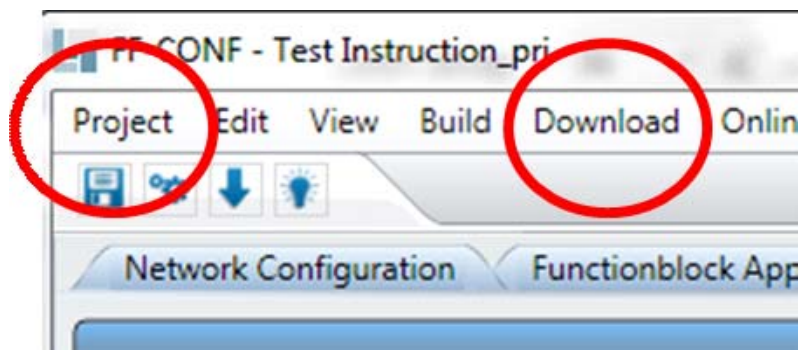
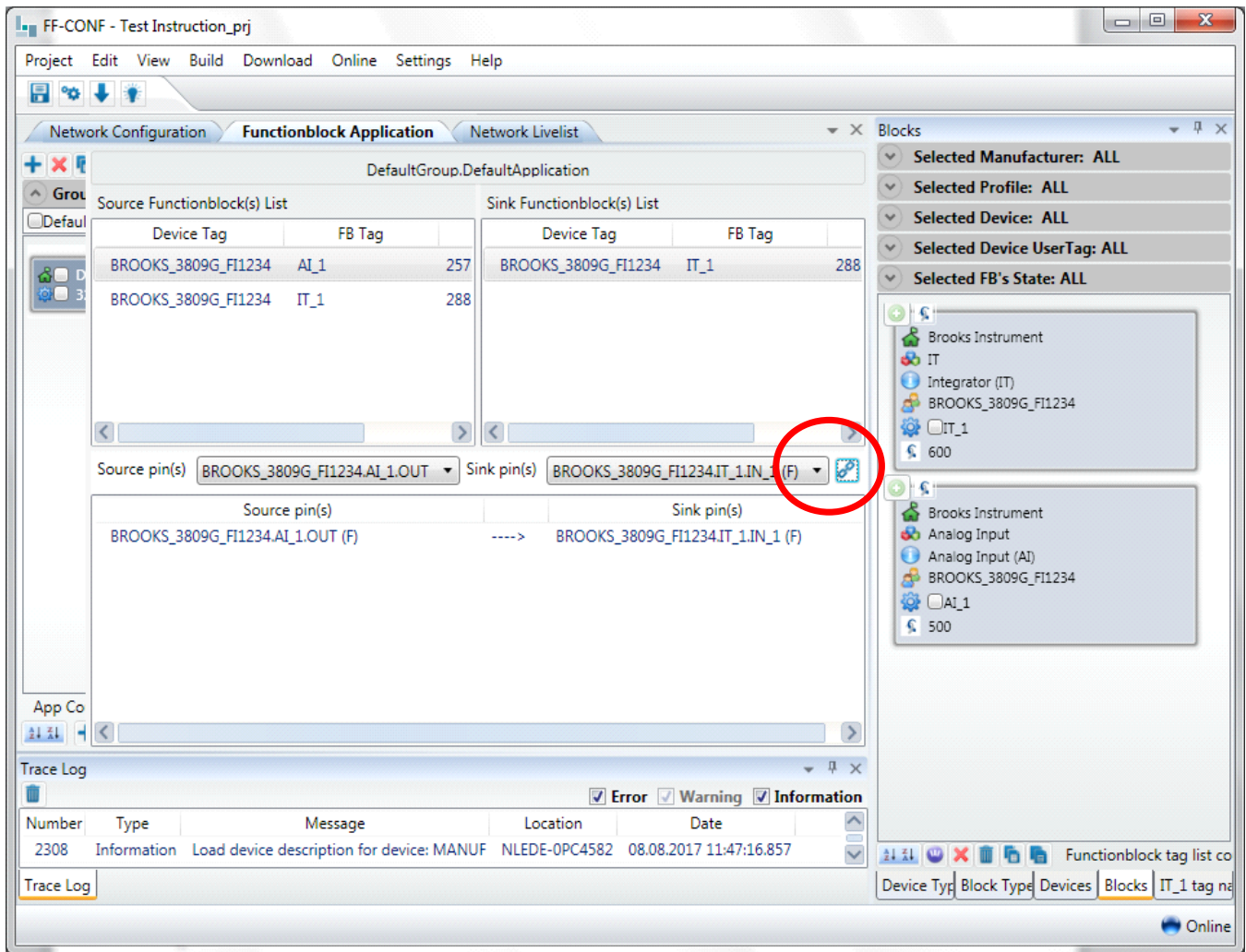

Model MT3809G FOUNDATION™ Fieldbus

Step 12: To operate AI function block, go to AI block in Network Configuration and set following parameters:

Parameter	Value
XD_SCALE.UNITS_INDEX	% (1342)
CHANNEL	Flow Channel
L_TYPE	Indirect

The screenshot displays the 'FF-CONF - Test Instruction_prj' software interface. The main window shows the 'Network Configuration' tab with the 'AI_1 (Analog Input)' block selected. The 'Parameters' table is shown below, with the following values circled in red:

Name	Configured value	Actual value	Default value	Min Value	Max Value	Type
SIMULATE.TRANSDUCER_STATUS		Bad:NonSpecific				U8
SIMULATE.TRANSDUCER_VALUE		0				F
SIMULATE.ENABLE_DISABLE		Disabled (1)				U8
XD_SCALE.EU_100		100				F
XD_SCALE.EU_0		0				F
XD_SCALE.UNITS_INDEX	% (1342)	% (1342)				U16
XD_SCALE.DECIMAL		0				I8
OUT_SCALE.EU_100		100				F
OUT_SCALE.EU_0		0				F
OUT_SCALE.UNITS_INDEX		0				U16
OUT_SCALE.DECIMAL		0				I8
GRANT_DENY.GRANT		None (0)				BStr
GRANT_DENY.DENY		None (0)				BStr
IO_OPTS		None (0)				BStr
STATUS_OPTS		None (0)				BStr
CHANNEL	Flow Channel (1)	Flow Channel (1)				U16
L_TYPE	Indirect (2)	Indirect (2)				U8
LOW_CUT		0		0.000000		F
PV_FTIME		0		0.000000		F

The 'H1 Device Properties' panel on the right shows the following settings:

- Device Identification:** PD Tag: BROOKS_3809G_F1234, Device ID: 0002462000MT3809xx0100
- Device Type:** CFF Revision: 0X0001, DD Revision: 0X0001, Device Revision: 0X0001, Dev Type: 0X2000, Manufacturer ID: 0X000246
- H1 Addressing:** Node ID: 35
- Link Master Settings:** BLM: False
- User Settings:** Tag Name: BROOKS_3809G_F1234

At the bottom of the interface, there are controls for 'Connected' (checked), a refresh button, '5 Sec(s)', 'Periodic read' (checked), and buttons for 'Read All', 'Set All', and 'Write all'. The status bar at the bottom right indicates 'Online'.

Step 13: First set MODE_BLK.TARGET to OOS (out of service), to be able to set desired OUT_SCALE UOM and OUT_SCALE value of AI function block.

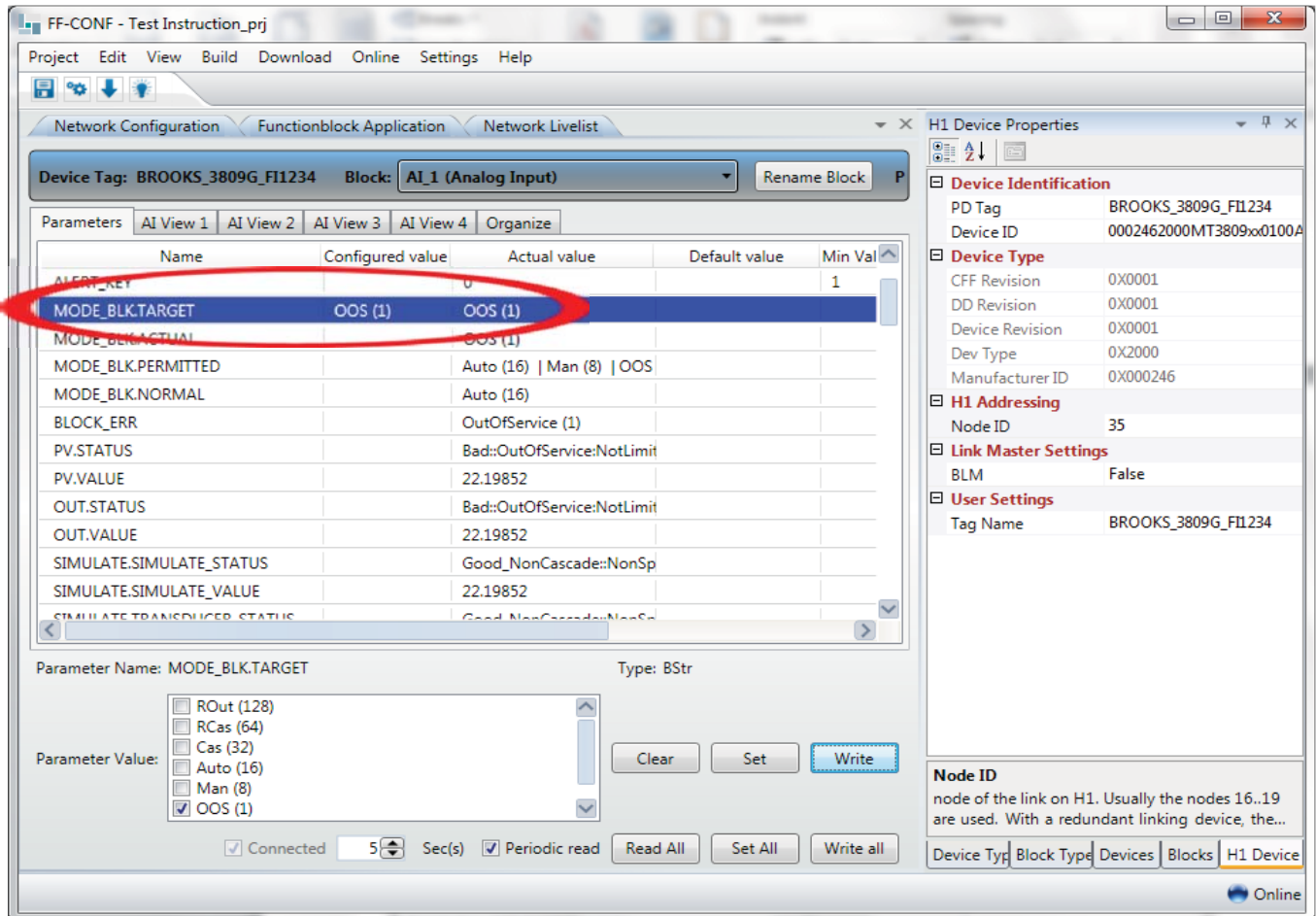

Model MT3809G FOUNDATION™ Fieldbus

Step 14: Write desired OUT_SCALE UOM and OUT_SCALE value settings, for example 200 m3/h.

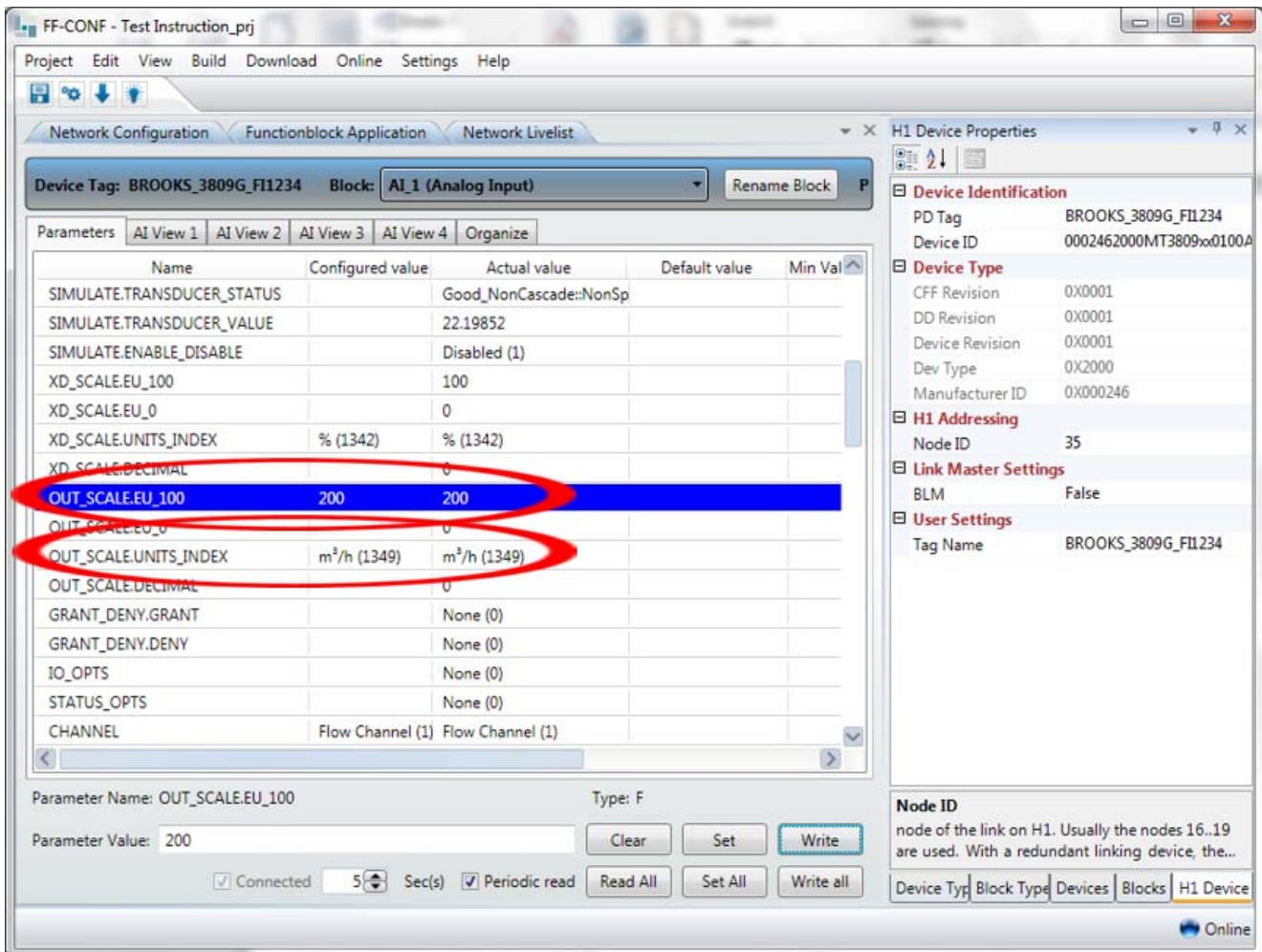

Step 17: Alarm settings in AI function block.

For this example, only HI_FLOW and HI_HI_FLOW alarms are set. Alarm limit example values (100 and 150) are referenced to 100% OUT.SCALE value (i.e. FS = 200 m3/h).

Make following settings:

- HI_HI_LIM: 150
- HI_LIM: 100
- Priorities: 2

The screenshot displays the FF-CONF software interface for configuring an AI_1 (Analog Input) function block. The main window shows the 'Parameters' table with the following data:

Name	Configured value	Actual value	Default value
BLOCK_ALM.TIME_STAMP		0	
BLOCK_ALM.SUB_CODE		Other (0)	
BLOCK_ALM.VALUE		0	
ALARM_SUM.CURRENT		None (0)	
ALARM_SUM.UNACKNOWLEDGEI		None (0)	
ALARM_SUM.UNREPORTED		None (0)	
ALARM_SUM.DISABLED	None (0)	None (0)	
ACK_OPTION	None (0)	None (0)	
ALARM_HYS		0.5	
HI_HI_PRI	2	2	
HI_HI_LIM	150	150	
HI_PRI	2	2	
HI_LIM	100	100	
LO_PRI		0	

The 'H1 Device Properties' panel on the right shows the following details:

- Device Identification:** PD Tag: BROOKS_3809G_FI1234, Device ID: 0002462000MT3809xx0100A0000
- Device Type:** CFF Revision: 0X0001, DD Revision: 0X0001, Device Revision: 0X0001, Dev Type: 0X2000, Manufacturer ID: 0X000246
- H1 Addressing:** Node ID: 35
- Link Master Settings:** BLM: False
- User Settings:** Tag Name: BROOKS_3809G_FI1234

The 'Trace Log' panel at the bottom shows a table with columns for Number, Type, Message, Location, and Date. The 'H1 Device Properties' panel also includes a 'Node ID' section with a description: 'node of the link on H1. Usually the nodes 16..19 are used. With a redundant linking device, the secondary s...'. At the bottom right, there is an 'Online' status indicator.

Model MT3809G FOUNDATION™ Fieldbus

Step 18: When OUT.VALUE > 100, Hi Alarm is presented

The screenshot shows the 'FF-CONF - Test Instruction_prj' application window. The 'H1 Device Properties' panel on the right displays the following information:

- Device Identification:** PD Tag: BROOKS_3809G_FI1234, Device ID: 0002462000MT3809xx0100A00000
- Device Type:** CFF Revision: 0X0001, DD Revision: 0X0001, Device Revision: 0X0001, Dev Type: 0X2000, Manufacturer ID: 0X000246
- H1 Addressing:** Node ID: 35
- Link Master Settings:** BLM: False
- User Settings:** Tag Name: BROOKS_3809G_FI1234

The main parameter table is as follows:

Name	Configured value	Actual value
BLOCK_ALM.UNACKNOWLEDGED		Uninitialized (0)
BLOCK_ALM.ALARM_STATE		Uninitialized (0)
BLOCK_ALM.TIME_STAMP		0
BLOCK_ALM.SUB_CODE		0
BLOCK_ALM.VALUE		0
ALARM_SUM.CURRENT		Hi Alarm (8192)
ALARM_SUM.UNACKNOWLEDGED		Hi Alm Unack (8192)
ALARM_SUM.UNREPORTED		Hi Alm Unrep (8192)
ALARM_SUM.DISABLED	None (0)	None (0)
ACK_OPTION	None (0)	None (0)
ALARM_HYS		0.5
HI_HI_PRI	2	2
HI_HI_LIM	150	150
HI_PRI	2	2
HI_LIM	100	100
LO_PRI		0

The 'ALARM_SUM.CURRENT' row is circled in red. Below the table, there are controls for 'Connected' (checked), a timer set to '5 Sec(s)', 'Periodic read' (checked), and buttons for 'Read All', 'Set All', and 'Write all'. A 'Trace Log' panel at the bottom shows 'Error', 'Warning', and 'Information' filters checked.

Step 19: When OUT.VALUE > 150, Hi Hi Alarm (and Hi Alarm) are presented

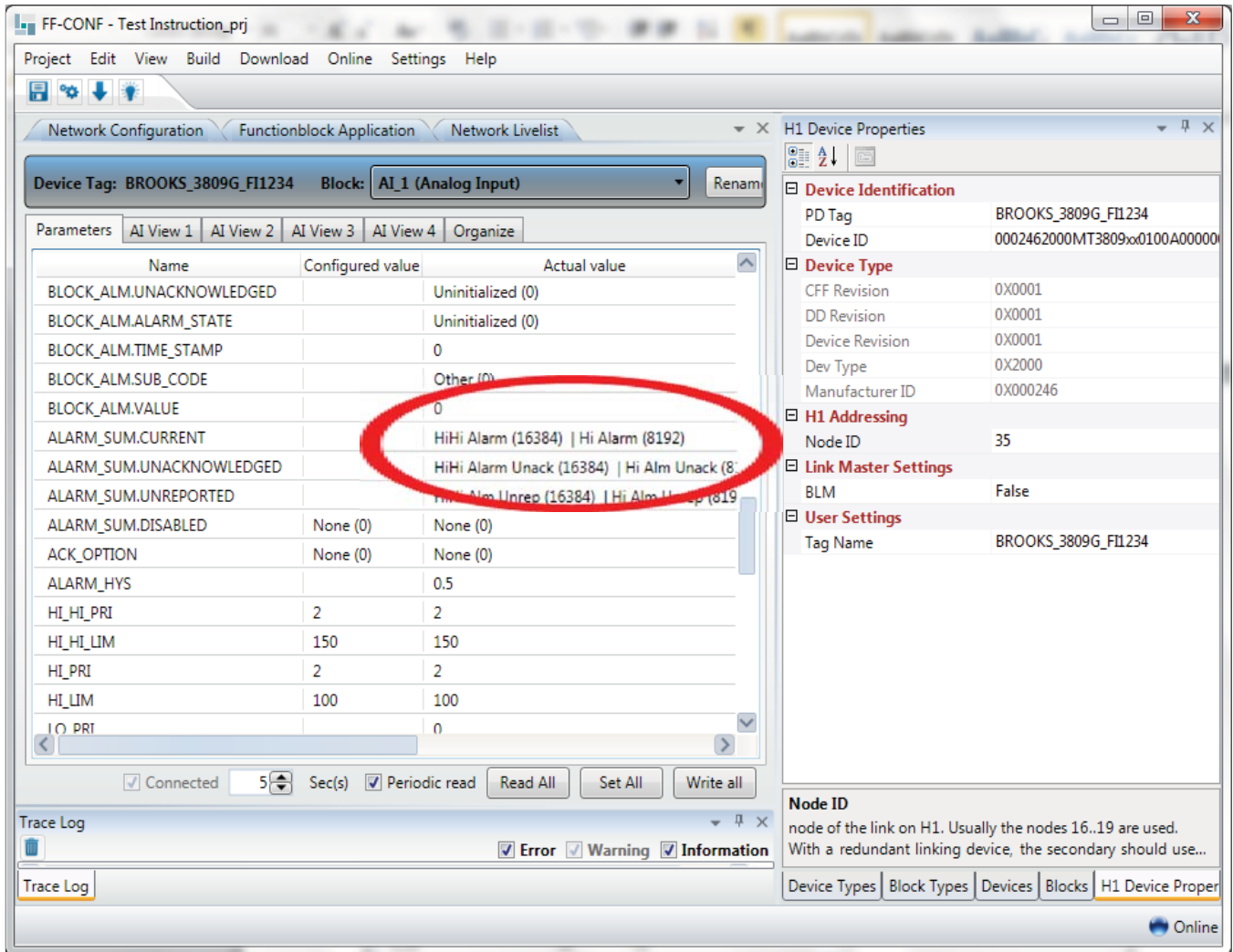

Model MT3809G FOUNDATION™ Fieldbus

Step 20: When OUT.VALUE < 100, Current Alarm is not indicated anymore.

The screenshot displays the 'H1 Device Properties' window for device 'BROOKS_3809G_FI1234'. The 'Parameters' table is as follows:

Name	Configured value	Actual value
BLOCK_ALM.UNACKNOWLEDGED		Uninitialized (0)
BLOCK_ALM.ALARM_STATE		Uninitialized (0)
BLOCK_ALM.TIME_STAMP		0
BLOCK_ALM.SUB_CODE		Other (0)
BLOCK_ALM.VALUE		0
ALARM_SUM.CURRENT		None (0)
ALARM_SUM.UNACKNOWLEDGED		HiHi Alarm Unack (16384) Hi Alm Unack (819)
ALARM_SUM.UNREPORTED		HiHi Alm Unrep (16384) Hi Alm Unrep (819)
ALARM_SUM.DISABLED	None (0)	None (0)
ACK_OPTION	None (0)	None (0)
ALARM_HYS		0.5
HI_HI_PRI	2	2
HI_HI_LIM	150	150
HI_PRI	2	2
HI_LIM	100	100
LO_PRI		0

The 'H1 Addressing' section shows Node ID 35. The 'Link Master Settings' section shows BLM set to False. The 'User Settings' section shows Tag Name as BROOKS_3809G_FI1234. The 'Node ID' section contains the text: 'node of the link on H1. Usually the nodes 16..19 are used. With a redundant linking device, the secondary should use...'

Step 21: To reset unacknowledged alarms, acknowledge HI_HI_ALARM and HI_ALARM.

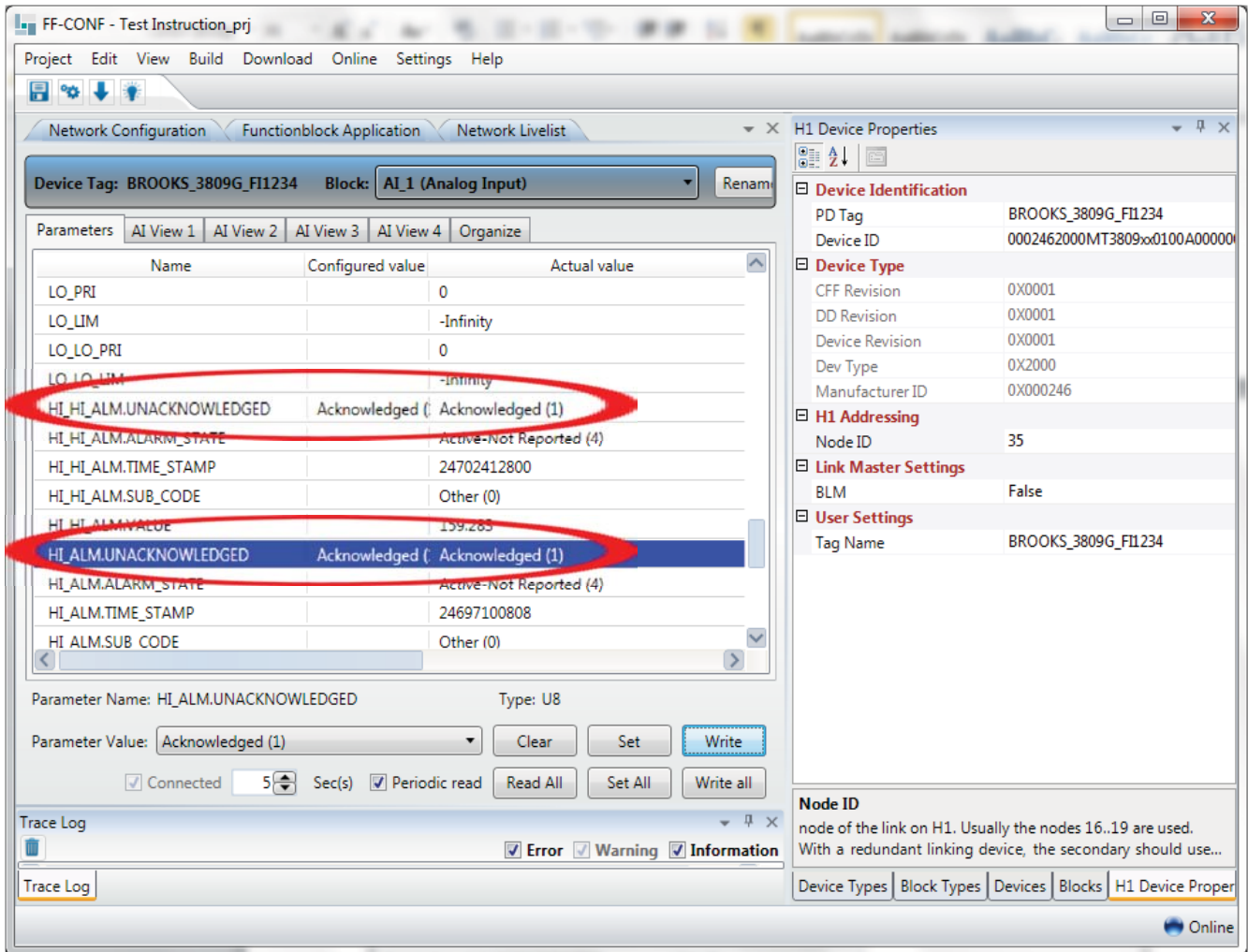

Model MT3809G FOUNDATION™ Fieldbus

Step 22: Unacknowledged alarms have been reset.

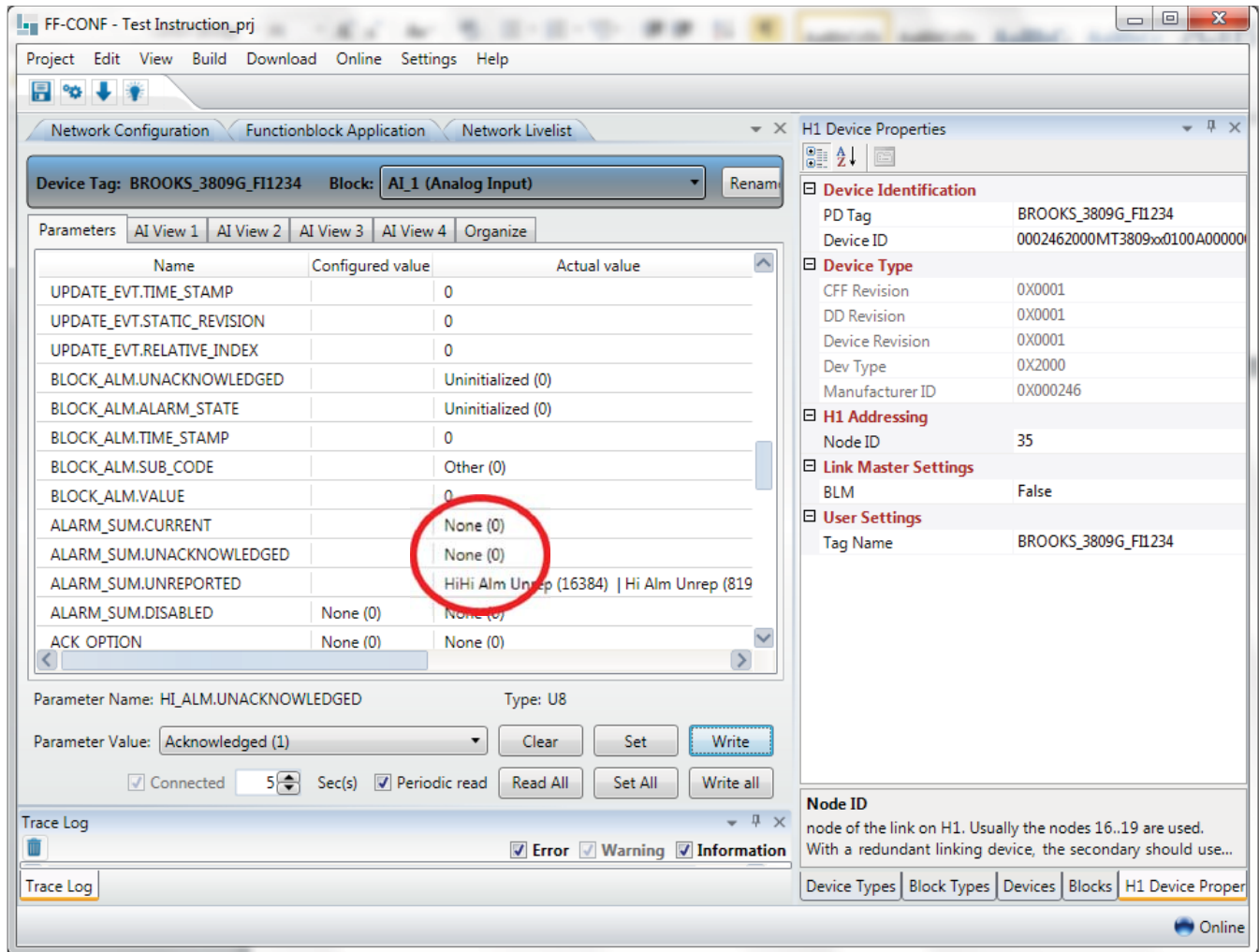

Step 23: Setting transmitter's physical alarm output contacts.
Go to AI transducer block, and set Hi-Flow and Lo-Flow limits as per desired values (in this example 90 and 10 respectively for a 0 - 100 UOM Primary Value scale).

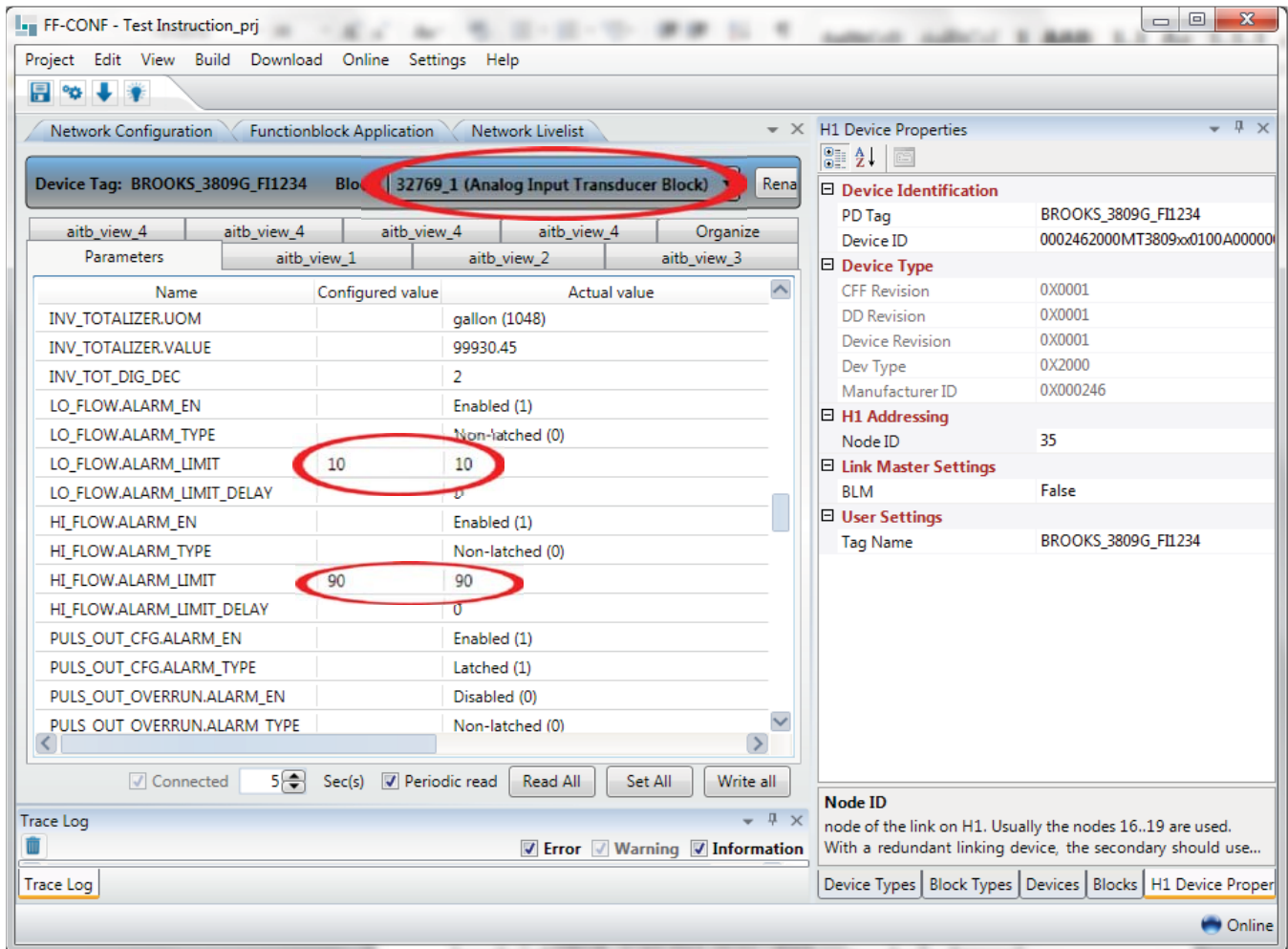

Model MT3809G FOUNDATION™ Fieldbus

Step 24: Observing flow alarm conditions

PV value < 10

- Lo Flow Alarm
- Transmitter Contact Output B closed
- Alarm Status AI transducer block: 16

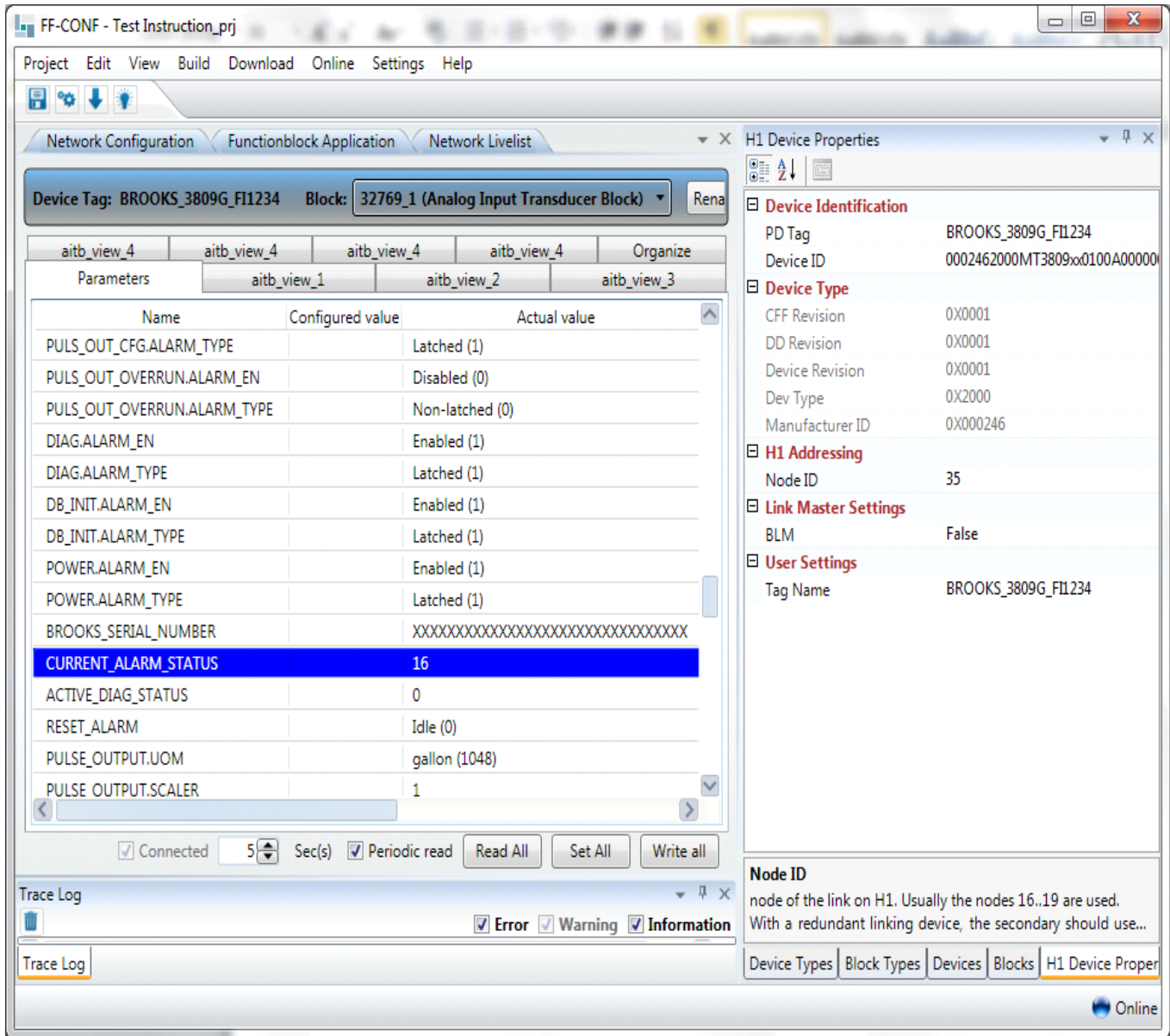

- PV value > 90
- Hi Flow Alarm
- Transmitter Contact Output A closed
- Alarm Status AI transducer block: 8

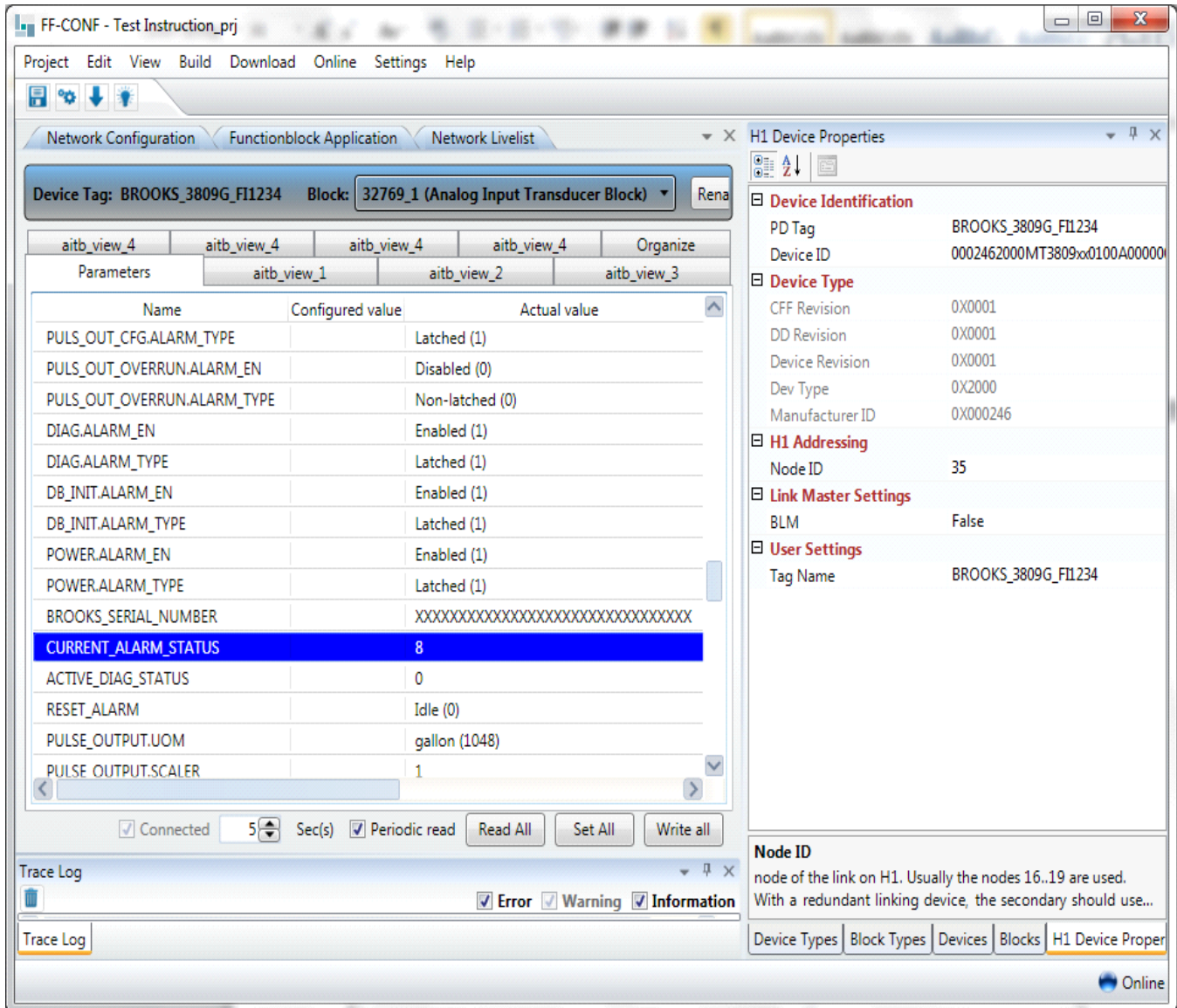

Model MT3809G FOUNDATION™ Fieldbus

90 > PV value > 10

- No Flow Alarm
- Transmitter Contact Output A and B both open
- Alarm Status AI transducer block: 0

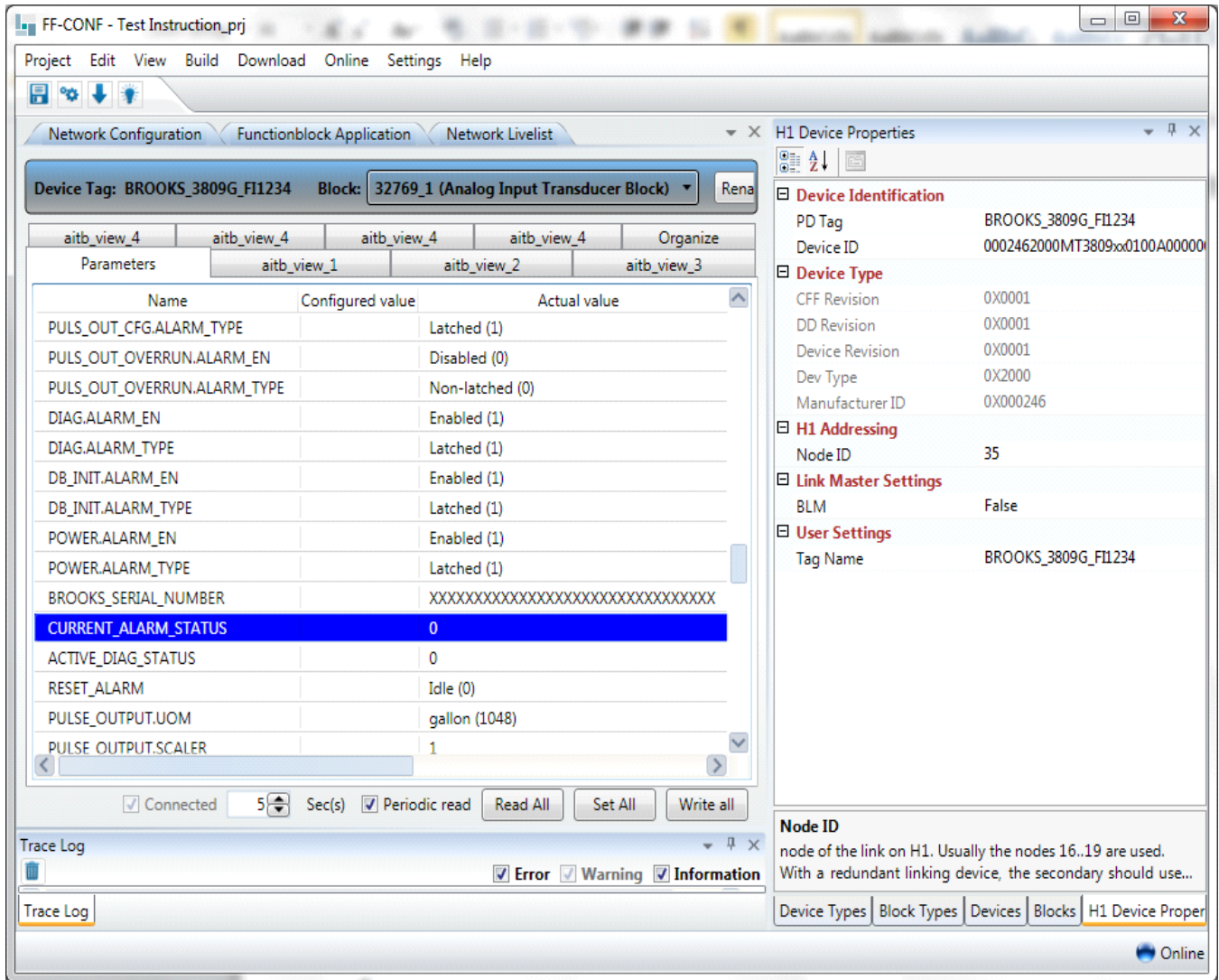

Alarm contact output location on transmitter terminal strip

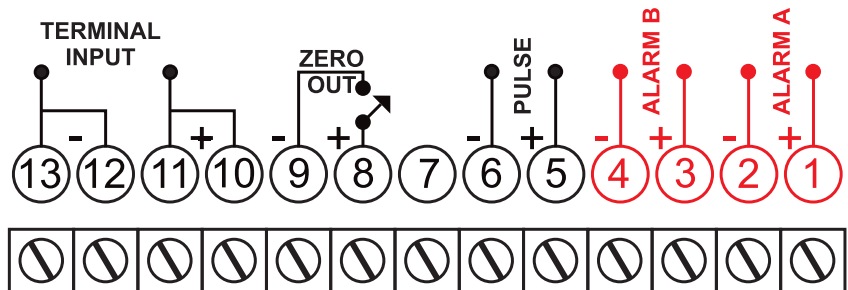

Step 25: Switch alarm output contacts to latching type.

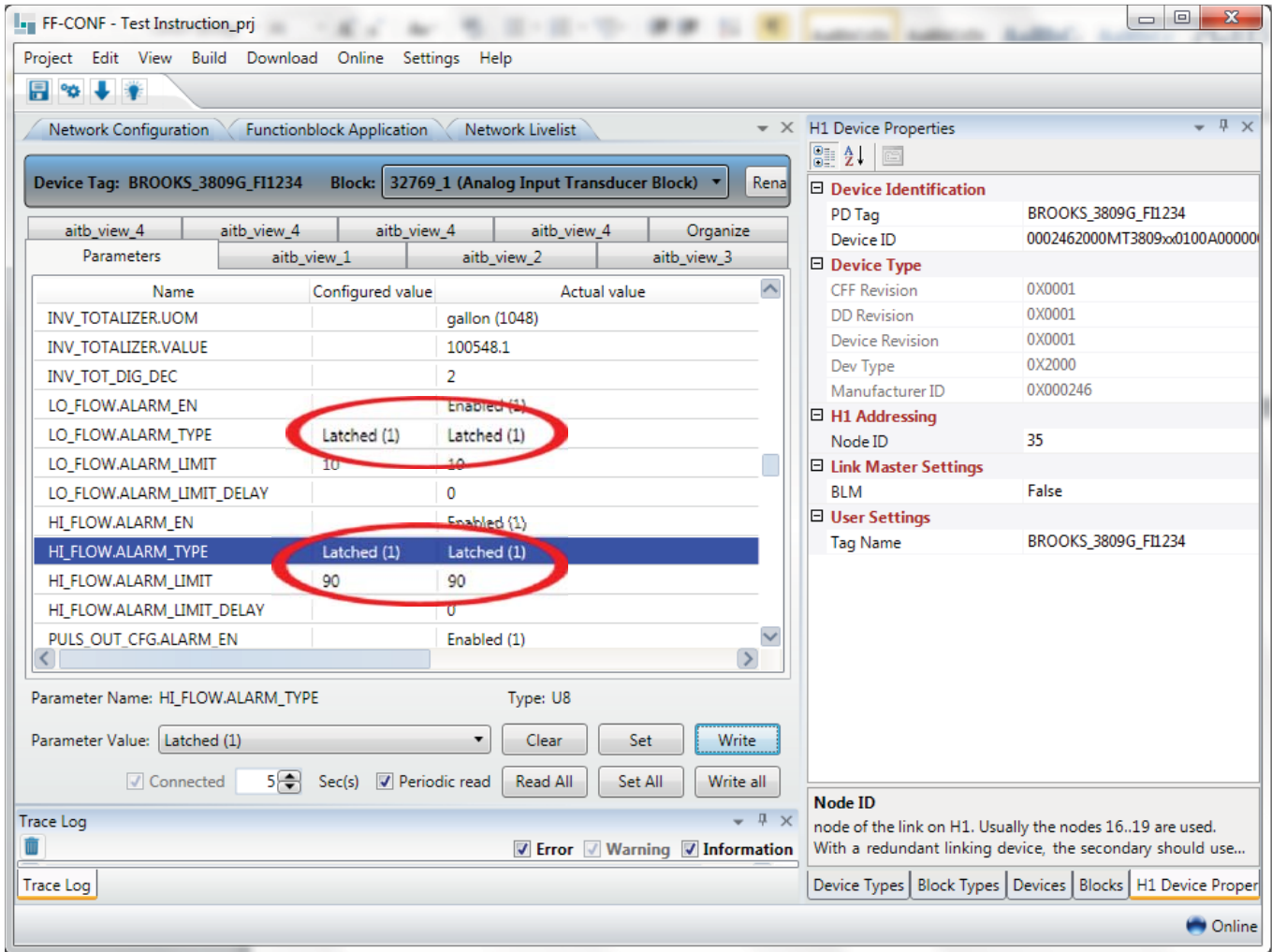

Note: The latching mode of the flow alarms is only reflecting to the alarm output contacts, and NOT to the Alarm Status in the AI transducer block.

*Once PV value has reached either > 90 or/and < 10, alarm output contacts A and B remain closed after reaching no alarm condition.
 To open alarm output contacts A and B again, an alarm reset is needed.*

Model MT3809G FOUNDATION™ Fieldbus

Step 26: Alarm output contacts reset.

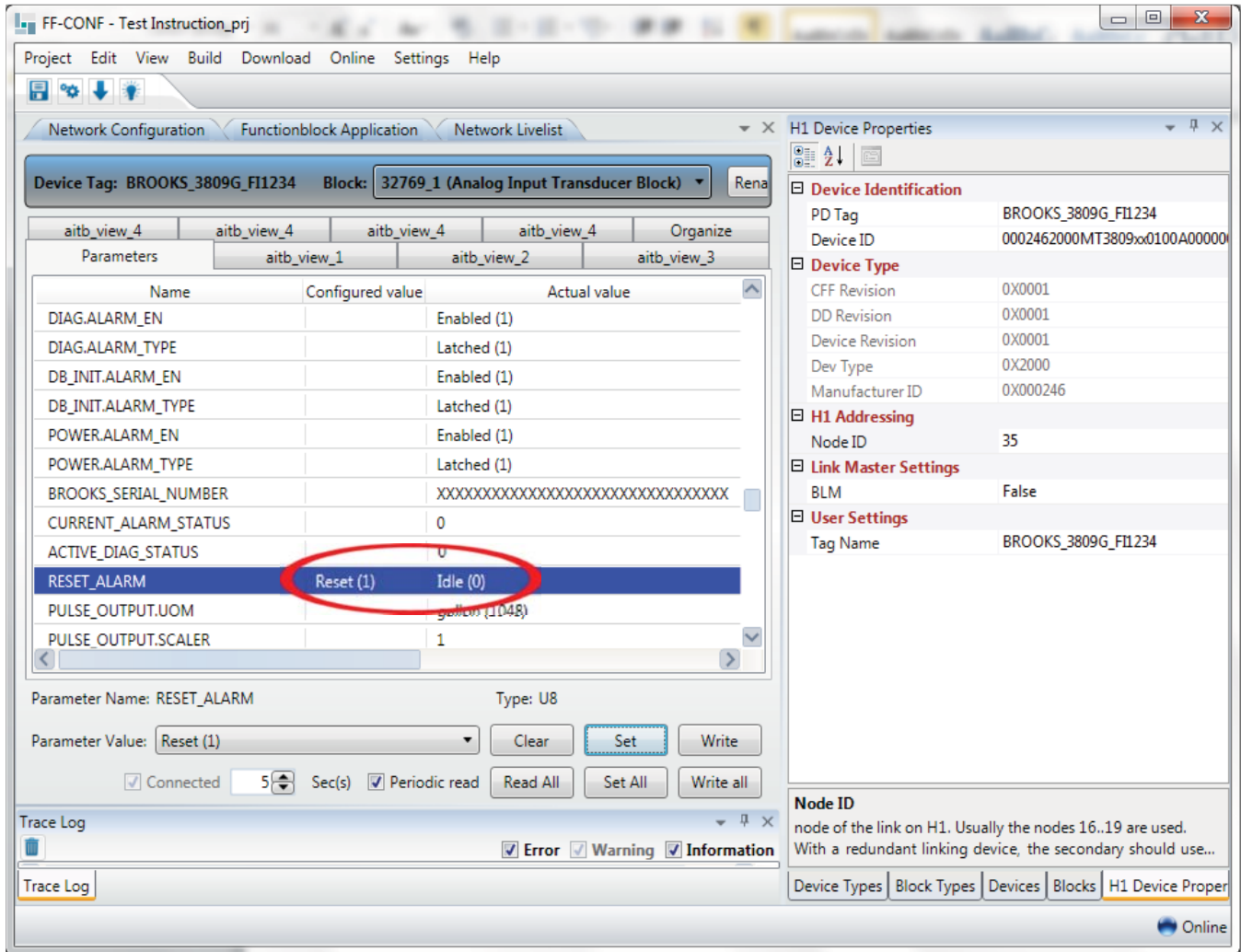

After Alarm Reset, alarm output contacts are switched to open condition.

Step 27: Alarm output contacts disabling.

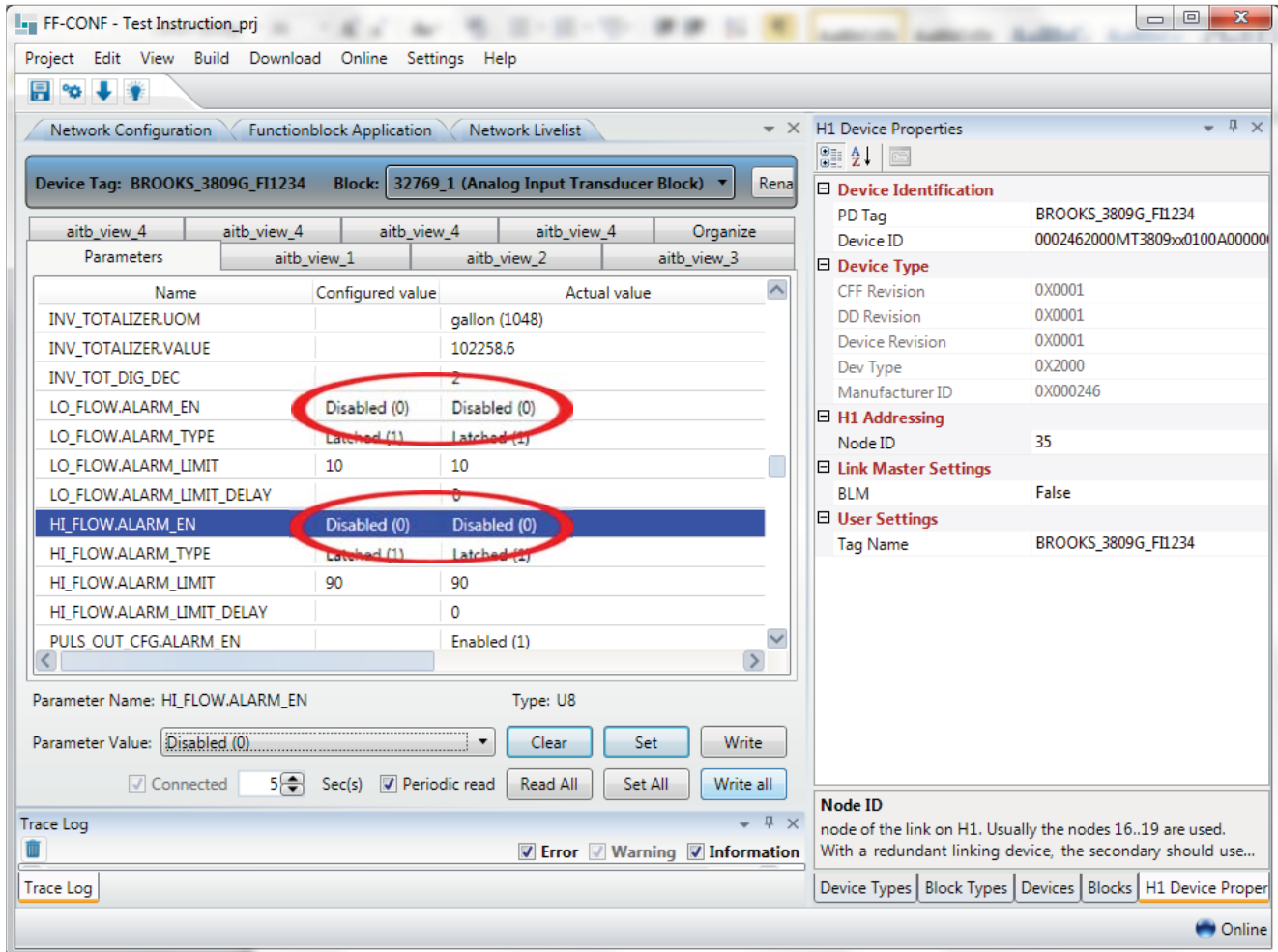

To discontinue alarm output contacts operation, set Hi Flow Alarm and Lo Flow Alarms to disabled.
Alarm output contacts remain in open condition, regardless of any PV value.

Model MT3809G FOUNDATION™ Fieldbus

LIMITED WARRANTY

Visit www.BrooksInstrument.com for the terms and conditions of our limited warranty.

BROOKS SERVICE AND SUPPORT

Brooks is committed to assuring all of our customers receive the ideal flow solution for their application, along with outstanding service and support to back it up. We operate first class repair facilities located around the world to provide rapid response and support. Each location utilizes primary standard calibration equipment to ensure accuracy and reliability for repairs and recalibration and is certified by our local Weights and Measures Authorities and traceable to the relevant International Standards.

Visit www.BrooksInstrument.com to locate the service location nearest to you.

START-UP SERVICE AND IN-SITU CALIBRATION

Brooks Instrument can provide start-up service prior to operation when required.

For some process applications, where ISO-9001 Quality Certification is important, it is mandatory to verify and/or (re)calibrate the products periodically. In many cases this service can be provided under in-situ conditions, and the results will be traceable to the relevant international quality standards.

SEMINARS AND TRAINING

Brooks Instrument can provide seminars and dedicated training to engineers, end users and maintenance persons.

Please contact your nearest sales representative for more details.

Due to Brooks Instrument's commitment to continuous improvement of our products, all specifications are subject to change without notice.

TRADEMARKS

Brooks Brooks Instrument, LLC

All other trademarks are the property of their respective owners.



Global Headquarters

Brooks Instrument
407 West Vine Street
Hatfield, PA
19440-0903 USA

Toll-Free (USA): 888-554-FLOW
T: 215-362-3500
F: 215-362-3745

BrooksAM@BrooksInstrument.com

A list of all Brooks Instrument locations and contact details can be found at www.BrooksInstrument.com