

EtherNet/IP™ Supplemental Manual

AMF Series Mass Flow Controllers & Meters

BROOKS®
INSTRUMENT

Beyond Measure

Essential Instructions

Read before proceeding!

Brooks Instrument designs, manufactures and tests its products to meet many national and international standards. These products must be properly installed, operated and maintained to ensure they continue to operate within their normal specifications. The following instructions must be adhered to and integrated into your safety program when installing, operating and maintaining Brooks Instrument products.

- To ensure proper performance, use qualified personnel to install, operate, update, program and maintain the product.
- Read all instructions prior to installing, operating and servicing the product. If this instruction manual is not the correct manual, please see back cover for local sales office contact information. Save this instruction manual for future reference.

▲ WARNING: Do not operate this instrument in excess of the specifications listed in the Instruction and Operation Manual.

Failure to heed this warning can result in serious personal injury and / or damage to the equipment.

- If you do not understand any of the instructions, contact your Brooks Instrument representative for clarification.
- Follow all warnings, cautions and instructions marked on and supplied with the product.

▲ WARNING: Prior to installation ensure this instrument has the required approval ratings to meet local and national codes.

Failure to heed this warning can result in serious injury and / or damage to the equipment.

- Install your equipment as specified in the installation instructions of the appropriate instruction manual and per applicable local and national codes. Connect all products to the proper electrical and pressure sources.
- Operation: (1) Slowly initiate flow into the system. Open process valves slowly to avoid low surges. (2) Check for leaks around the flow meter inlet and outlet connections. If no leaks are present, bring the system up to the operating pressure.
- Please make sure that the process line pressure is removed prior to service. When replacement parts are required, ensure that qualified people use replacement parts specified by Brooks Instrument. Unauthorized parts and procedures can affect the product's performance and place the safe operation of your process at risk. Look-alike substitutions may result in fire, electrical hazards or improper operation.
- Ensure that all equipment doors are closed and protective covers are in place to prevent electrical shock and personal injury, except when maintenance is being performed by qualified persons.

▲ WARNING: For liquid flow devices, if the inlet and outlet valves adjacent to the devices are to be closed for any reason, the devices must be completely drained. Failure to do so may result in thermal expansion of the liquid that can rupture the device and may cause personal injury.

ESD (Electrostatic Discharge)

▲ CAUTION: This instrument contains electronic components that are susceptible to damage by static electricity. Proper handling procedures must be observed during the removal, installation or other handling of internal circuit boards or devices.

Handling Procedure:

1. Power to unit must be removed.
2. Personnel must be grounded, via a wrist strap or other safe, suitable means before any printed circuit card or other internal device is installed, removed or adjusted.
3. Printed circuit boards must be transported in a conductive container. Boards must not be removed from protective enclosure until immediately before installation. Removed boards must immediately be placed in protective container for transport, storage or return to factory.

Comments

This instrument is not unique in its content of ESD (electrostatic discharge) sensitive components. Most modern electronic designs contain components that utilize metal oxide technology (NMOS, SMOS, etc.) Experience has proven that even small amounts of static electricity can damage or destroy these devices. Damaged components, even though they appear to function properly, exhibit early failure.

Section 1: General Information	8
Section 2: Definition of Terms	9
Section 3: Before Starting	
Background & Assumptions	10
Compliance	10
Notations	10
Numbers	10
EPATHS	10
Section 4: Quick Start	
Physical Interfaces	11
Power Supply & Communications AMF	12
Communications Notes: AMF	14
MOD LED	14
NET LED	14
TCP/IP Network Configuration	15
Class 1 Connection (Cyclic I/O)	15
Class 3 Connection (Acyclic I/O)	16
Section 5: Configuration	
Commonly Configured Attributes	17
Data Units	18
Safe Mode	18
Valve Safe Mode	18
Process Gas Page Configuration	19
Class 1 Connections	19
Note: Gas Calibration Class Instance	19
Data Assemblies	20
Configuration Assembly	20
Output Assemblies	22
Input Only Outputs and Inputs	23
Input Assemblies	23
Section 6: Detailed Configuration	
Overview	25
Services	26
Identity Class [0x01]	26
Attributes	26
Services	28
Assembly Class [0x04]	29
Attributes	29
Services	29
Device Manager Class [0x64]	30
Attributes	30
Services	31
Flow Sensor Class [0xA2]	31
Attributes	31
Services	31
Flow Meter Class [0xA9]	32
Attributes	32
Services	33
RTB Class [0xA1]	34
Attributes	34
Services	35

Valve Driver Class [0x96].....	35
Attributes	35
Services.....	37
Flow Controller Class [0x9E]	37
Attributes	37
Services.....	39
Process Gas Class [0x66]	39
Attributes	40
Services.....	40
Temperature Meter Class [0xA4]	40
Attributes	41
Services.....	41
Status Class [0xB8]	41
Attributes	42
Services.....	44

Section 7: Status

Device Status {184-1-6}.....	45
Bit 0: Device is Executing [Device_Status_Dev_Exec]	45
Bit 1: Device is Warming Up.....	45
Bit 2: Device is Zeroing	45
Bit 6: Valve Override [Device_Status_Valve_Override].....	46
Bit 7: Control Override [Device_Status_Ctrl_Override]	46
Bit 8: Device Error [Device_Status_Dev_Error].....	46
Bit 9: Device Alarm [Device_Status_Dev_Alarm].....	46
Bit 10: Device Warning [Device_Status_Dev_Warning]	47
Bit 12: Control Ramping [Device_Status_Ctrl_Ramping]	47
Warnings {184-1-5}.....	47
Bit 0: Low Flow Warning [Active_Warnings_Low_Flow].....	47
Bit 1: High Flow Warning [Active_Warnings_High_Flow]	48
Bit 3: Choked Flow Warning [Active_Warnings_Choked_Flow]	48
Bit 4: Excessive Zero Drift Warning [Active_Warnings_Zero_Drift].....	49
Bit 8: Valve High Warning [Active_Warnings_Valve_High].....	49
Bit 9: Valve Low Warning [Active_Warnings_Valve_Low]	49
Bit 11: Setpoint Deviation [Active_Warnings_SP_Deviation].....	50
Bit 13: Setpoint Overrange [Active_Warnings_SP_Overrange]	50
Bit 14: Setpoint Limited [Active_Warnings_SP_Limited]	51
Bit 15: Zero Recommended	51
Bit 16: Overhaul Due [Active_Warnings_Overhaul_Due].....	51
Bit 17: Calibration Due [Active_Warnings_Cal_Due]	52
Bit 24: High Temperature Warning [Active_Warnings_High_Temp]	52
Bit 25: Low Temperature Warning [Active_Warnings_Low_Temp].....	52
Bit 26: Power Supply Warning.....	53
Bit 31: CPU Temperature High Warning.....	53
Alarms {184-1-4}.....	54
Bit 0: Low Flow Alarm [Active_Alarms_Low_Flow].....	54
Bit 1: High Flow Alarm [Active_Alarms_High_Flow]	54
Bit 2: No Flow Alarm [Active_Alarms_No_Flow].....	55
Bit 3: Choked Flow Alarm [Active_Alarms_Choked_Flow]	55
Bit 5: High Temperature Alarm [Active_Alarms_High_Temp]	56
Bit 6: Low Temperature Alarm [Active_Alarms_Low_Temp].....	56
Bit 7: Valve High Alarm [Active_Alarms_Valve_High].....	56
Bit 8: Valve Low Alarm [Active_Alarms_Valve_Low]	56
Bit 15: Invalid Process Gas Page Selected [Active_Alarms_Invalid_Cal_Page]	57
Bit 18: Internal Communication Alarm	57

Bit 23: Using Backup NV Memory [Active_Alarms_NV_Mem]	57
Bit 31: Internal Alarm	57
Errors {184-1-3}	58
Bit 0: Internal Failure	58
Bit 2: Back Streaming Error [Active_Errors_Bk_Stream]	58
Bit 8: Temperature Sensor Fail	58
Bit 9: Flow Sensor Fail	58
Bit 10: Valve Drive Fail	58
Bit 18: Internal Communication Error [Active_Errors_Int_Comms]	59
Bit 23: NV Memory Fail [Active_Errors_NV_Mem_Fail]	59
Typical Status High/Low Processing	59
Section 8: Troubleshooting	61
Section 9: Appendix	
Appendix A - Ethernet/IP Connections	62
Appendix B - Data Type Definitions	63
Appendix C - Data Units	64
Appendix D - Service Summary Details	65
Section 10: Glossary	
Assembly	66
Attribute	66
Class	66
Connection	66
Device Profile	66
EDS	66
EPATH	66
Expected Packet Rate (EPR)	67
Class 3 Connection	67
Class 1 Connection	67
Instance	67
Safe State (Safe Mode)	67
Service	67

**Table
Number**

2-1	Definitions	9
4-1	Pin Labeling of M8 Male Device and Female Mating Cable Connector AMF	12
4-2	Wire Labeling of M8 Female Mating Cable Connector	13
4-3	M8 Female Mating Cable Part Numbers	13
4-4	MOD LED Indicator Definitions	14
4-5	NET LED Indicator Definitions	14
4-6	MFC Exclusive Owner Connection Configuration	15
4-7	MFM Input Only Connection Configuration	16
5-1	Commonly Configured Parameters	17
5-2	Configurable Data Units Attributes	18
5-3	Safe State	18
5-4	MFC Class 1 Connection Configurations	19
5-5	MFC Configuration Assembly Definition	20
5-6	MFM Configuration Assembly Definition	21
5-7	MFC Process Control 1 Assembly	22
5-8	MFM Process Control 1 Assembly	22
5-9	MFC Process Data Assembly	23
5-10	MFM Detailed Process Monitoring Assembly	24
6-1	Accessible Classes	25
6-2	Common Services for all Classes	26
6-3	Identity Instance Attributes	26
6-4	Identity Class Status	27
6-5	Identity Class Reset Service	28
6-6	Identity Class Reset Service Parameters	28
6-7	Identity Class Reset Service Response	28
6-8	Assembly Class Instance Attributes	29
6-9	Device Manager Instance Attributes	30
6-10	Flow Sensor Instance Attributes	31
6-11	Flow Meter Instance Attributes	32
6-12	RTB Class Instance Attributes	34
6-13	Value Driver Class Instance Attributes	35
6-14	Override	36
6-15	Safe State	37
6-16	Flow Controller Class Instance Attributes	37
6-17	Control Overrides	39
6-18	Process Gas Instance 0 Attributes	40
6-19	Temperature Meter Class Instance 1 Attributes	41
6-20	Status Class Instance 1..n Attributes	42
6-21	Active Error Bit Definitions	42
6-22	Active Alarms Bit Definitions	43
6-23	Active Warnings Bit Definitions	43
6-24	Device Status Bit Definitions	44
9-1	Data Types	63
9-2	Volumetric Flow Units Table	64
9-3	Actuator Units	64
9-4	Temperature Units	64
9-5	Volume Units Table (Used by Totalizers)	64
9-6	Get Attribute Single Service Parameters	65
9-7	Success Response Data	65
9-8	Set Attribute Single Service Parameters	65
9-9	Success Response Data	65

Figure
Number

4-1	EtherNet/IP Top Cover.....	12
4-2	M8 Male Device Connector Pin Layout, Pin Side View AMF.....	12
4-3	M8 Female Mating Cable.....	13
4-4	M8 Female Mating Cable Connector Pin.....	13

Many applications of Flow Controllers/Meters are moving to increase the use of automation. Automation comes in many forms: PLC's (Programmable Logic Controllers, like those from Allen/Bradley), DCS's (Distributed Control Systems, such as Emerson's DeltaV), PC-based solutions (National Instruments LabVIEW™), and Ethernet-based field buses. Digital communications from these varied systems and the devices they measure and control, are a very effective means of not only accomplishing more effective and rapid system integration, but also providing greatly improved system diagnostics and maintainability. EtherNet/IP™ is an Ethernet-based communications system for industrial automation applications built upon the IEEE 802.3 standards and TCP/IP communications standards. EtherNet/IP™ utilizes the Common Industrial Protocol (CIP™) as a top layer (application layer) of the TCP/IP protocol stack. This solution leverages the power of the internet and enterprise connectivity, combined with the functionality and comprehensive suite of messages and services for manufacturing automation applications.

Table 2-1 Definitions

Abbreviation	Description
Byte	A Byte refers to 8 consecutive bits.
CRC	Cyclic Redundancy Check (Checksum)
EIP	Ethernet/IP
EDS	Electronic Data Sheet
EtherNet/IP™	Ethernet - Industrial Protocol
LSB	Least Significant Bit or Least Significant Byte
MAC	Media Access Control is responsible for address checking and is most often done in the hardware of a NIC.
Master	A Master is a unit which controls the Slaves, feeding them commands and receiving status reports in exchange.
MFC/MFM	Mass Flow Controller / Mass Flow Meter
MSB	Most Significant Bit or Most Significant Byte
MTU	Maximum Transmission Unit. The maximum payload that a standard Ethernet Frame can hold. The MTU is set at 1500 bytes (Not considering the Header and Checksum).
NIC	Network Interface Controller. A hardware component that connects a computer to a network.
NV	Non-Volatile
OSI Model	A standardized representation for how a communication system can be organized. (e.g., a protocol stack) The model is divided into layers, each responsible for a part of the communication.
RO	Read Only
RT	Real-time. A system that adheres to strict timing demands.
RW	Read / Write
Slave	A Slave is a unit (node) on the network (e.g., an MFC). The Slave is connected to a Master.
Stack	A synonym for the implementation of the layers of a protocol.
TCP/IP	Transport Control Protocol/Internet Protocol
Topology	The way a network (Master & Slaves) is inter-connected. The overall layout. (e.g., Star, Tree, Line Topology)
WO	Write Only
DLR	Device Level Ring

Background & Assumptions

This manual is a supplement to the AMF Series Installation and Operation Manual. It is recommended that the owner read that manual first before continuing with this supplement.

This manual assumes a basic knowledge and understanding of the EtherNet/IP™ protocol, its topology and its method of logically accessing the data or parameters contained within a device. This manual also assumes basic knowledge and understanding regarding the operation of Mass Flow Controllers or Mass Flow Meters. This manual is not intended to be a replacement to the ODVA specification, which is still the authoritative definition and description of EtherNet/IP™ communications. It is recommended, but not required for the purposes of this manual, that the user obtain a copy of the EtherNet/IP™ specification from ODVA (<http://www.odva.org/>).

This manual does not make any assumptions about any manufacturer of equipment or custom software used by the user to communicate with the Brooks Instrument device but assumes the user has thorough understanding of such equipment and any configuration software.

Compliance

The AMF Series Mass Flow Controller (MFC) or Mass Flow Meter (MFM) conforms to the ODVA specified Device Profile for a Generic Device.

Notations

This section details notations and conventions used throughout the manual. It is recommended that the reader become very familiar with these conventions.

Hypertext links are used in the manual to assist in navigating. A glossary is provided for reference in Section: 10 Glossary to aid in reviewing and/or to define any unfamiliar terms.

Numbers

Numeric values used throughout this manual will be clearly denoted as to the base numeric system it represents. All hexadecimal numbers (base 16) will be prefixed with a 0x, like 0xA4. All binary numbers (base 2) will be suffixed with a b, like 1001b. All other numbers not annotated this way will be assumed decimal (base 10).

EPATHS

EPATH's will be denoted within brackets [] or braces {}, like [0x31, 1, 3], {0x31-1-3} which represents, left to right, the Class ID (hexadecimal or decimal), Instance ID (decimal), and Attribute ID (decimal)

This section assumes that the owner of the AMF Series device has a fully operational and trouble-free communications network with appropriate power supplies. This section also assumes that a master device or application is connected to the network, capable of Class 1 and Class 3 message communications. Both types of data communication modes are supported by the AMF Series EtherNet/IP™ device.

Physical Interfaces

The available physical interfaces on the EtherNet/IP™ AMF device are listed below (Figure 4-4):

- 5 pin M8 threaded male connector for power.
- RJ-45 connectors labeled “1” and “2” for Ethernet/IP™ Communications.
- USB-C diagnostic port labeled ‘DIAG,’ refer to the AMF Series Mass Flow Controllers & Meters Installation and Operations Manual (IOM) for more details.

Power Supply & Communications AMF

Power needs to be supplied via the M8 connector. See Table 4-3.

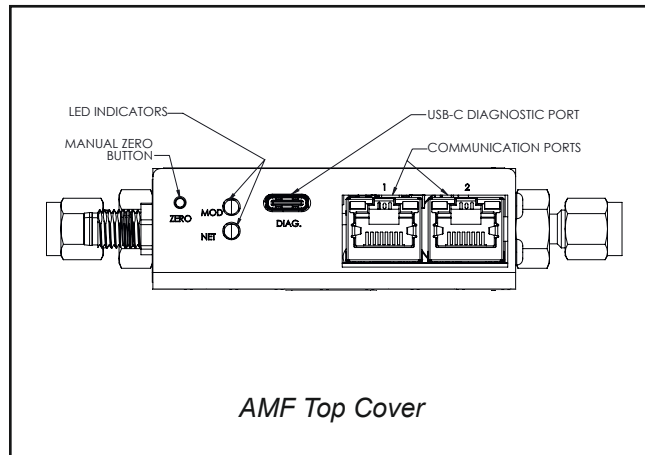

Figure 4-1: EtherNet/IP Top Cover

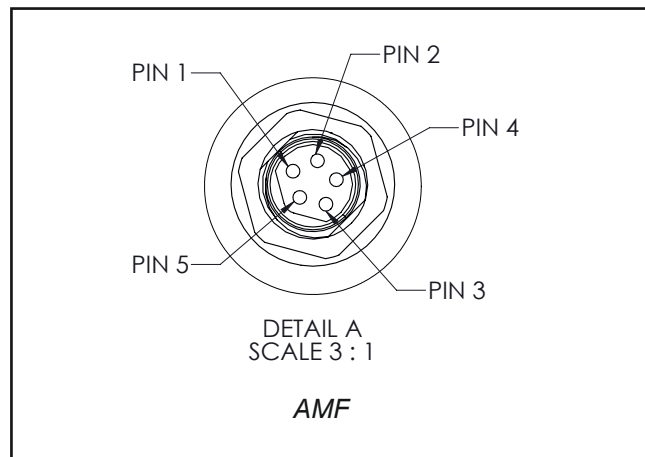

Figure 4-2: M8 Male Device Connector Pin Layout, Pin Side View AMF

Table 4-1: Pin Labeling of M8 Male Device and Female Mating Cable Connector AMF

Pin Label	Function at Remote Connector
V+	Positive Power Supply Voltage
V-	Power Supply Ground
N/C	Not Connected

M8 power mating cables can be purchased as a second line item as below.

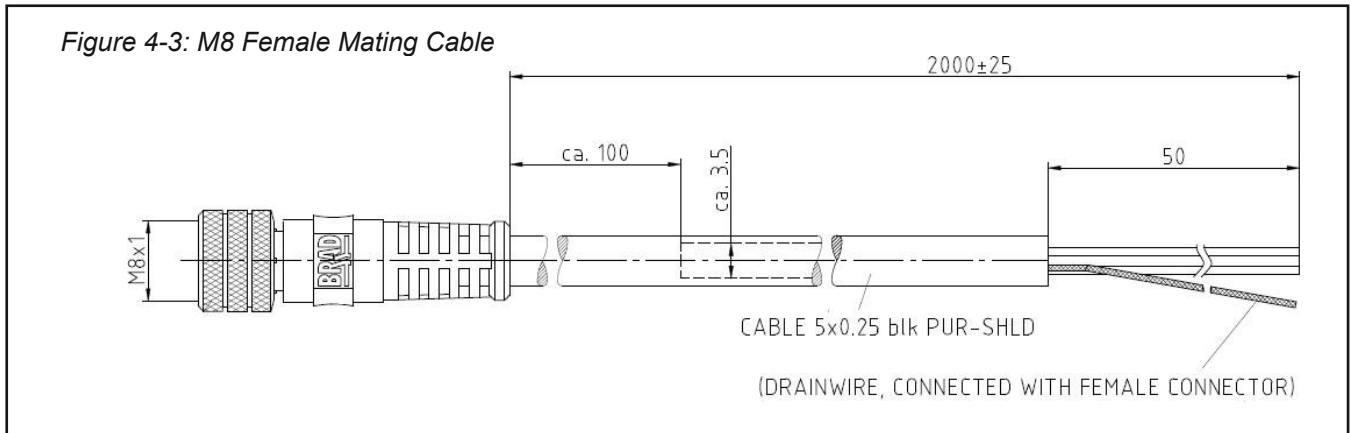

Figure 4-4: M8 Female Mating Cable Connector Pin

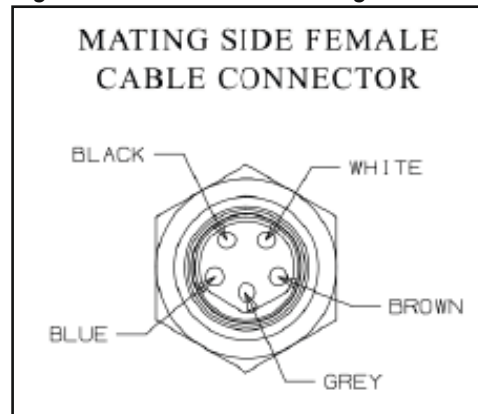

Table 4-2: Wire Labeling of M8 Female Mating Cable Connector

Wire Color	Wire Label	Function at Remote Connector
Blue	V	Power Supply Ground
Brown	V+	Positive Power Supply Voltage
Black	N/C	Not Connected
White	N/C	Not Connected
Grey	N/C	Not Connected

Table 4-3: M8 Female Mating Cable Part Numbers

Supplier	Part Number	Description
Brooks Instrument	124X049AAA	M8 Mating Cable 2m
	124X050AAA	M8 Mating Cable 5m

Communications Notes: AMF

As noted in the Physical Interface Sections, above, each AMF Series EtherNet/IP™ device has (2) RJ-45 Ethernet Connection ports labeled 1 and 2 (Figure 4-4). Network connections can be made to either or both ports, depending on the network topology. The AMF Series EtherNet/IP™ device will support star, linear and DLR (Device Level Ring) topologies.

The AMF Series EtherNet/IP™ device supports auto-negotiation of the communications link. Both ports support data rates of 10/100 Mbps and Half/Full duplex communications. The device may be directly connected to the Ethernet NIC on a desktop or laptop PC for configuration and commissioning activities.

MOD LED*Table 4-4: MOD LED Indicator Definitions*

Indicator State	Summary	Requirement
Off	No power	No power is supplied to the device.
Solid Green	Device Operational	Device is operating correctly.
Flashing Green	Standby	Device has not been configured.
Flashing Red	Major Recoverable Fault	The device has detected a Major Recoverable Fault (Alarm) The alarm must be enabled for the LED to flash red.
Solid Red	Major Unrecoverable Fault	The device has detected a Major Unrecoverable fault (Error).
Flashing Green / Red	Self-test	The device is performing its power-up testing.

NET LED*Table 4-5: NET LED Indicator Definitions*

Indicator State	Summary	Requirement
Off	Not powered, or no IP address.	The device is powered off or is powered on but with no IP address configured.
Flashing Green	No connections	An IP address is configured, but no CIP connections are established with the device.
Steady Green	Connected	An IP address is configured, at least one I/O connection (transport class 1) is established with the device.
Flashing Red	Connection Timeout	An IP address is configured, and an Exclusive Owner connection has timed out. The NET indicator will return to steady green when the Exclusive Owner connection is reestablished.
Steady Red	Duplicate IP	The device has detected that its IP address is already in use.
Flashing Green / Red	Self-test	The device is performing its power-up testing.

TCP/IP Network Configuration

The TCP/IP network settings can be configured using the device's embedded web-based interface or through a variety of network utilities. By default, AMF Series EtherNet/IP™ devices are shipped with a fixed IP address. The device defaults to the following TCP/IP connections settings:

IP Address: 192.168.1.100
 NET Mask: 255.255.255.0
 Gateway Address: 0.0.0.0
 DNS1: 0.0.0.0
 DNS2: 0.0.0.0

To configure using the web-based interface, connect the device to the network that is configured with the same subnet as the device (192.168.1.xxx). Open a web browser and enter the IP address of the device as the URL.

The web-based interface opens in read-only mode. To change the configuration, click the Login Tab. From the pulldown, select Configure or Control. The default password for Configure is 'configure'. The default password for Control is 'control'.

Click the Network Tab. By default, static is selected. The network configuration fields are active. Click 'Submit' after setting the network configuration.

NOTE: Once the settings have been changed, the TCP/IP address will need to be reentered in the URL field of the browser to reconnect with the device and confirm the network settings.

Class 1 Connection (Cyclic I/O)

The following connection configuration can be used to create a Class 1 connection (also known as I/O Connection or Cyclic Data Connection). See Section 5 for more information on other Class 1 connection configurations.

(See Appendix A for details on Class 1 Connection Types)

MFC

Table 4-6: MFC Exclusive Owner Connection Configuration

Output ³ Assembly ID	110
Output Assembly Size	28 bytes
Output Assembly RPI	>= 50 msec
Input ³ Assembly	150
Input Assembly Size	88 bytes
Input Assembly RPI	>= 50 msec
Configuration Assembly ¹	100
Configuration Assembly Size ²	88 bytes

1. If no configuration data is to be transferred to the device, set the configuration assembly ID to 0 with a data length of 0.

2. All field values in the configuration assembly data must have valid values or the assembly data will be rejected along with the connection open request.

3. The terms Input/Output are relative to the Master/Controller

MFM*Table 4-7: MFM Input Only Connection Configuration*

Output ³ Assembly ID	110
Output Assembly Size	12 bytes
Output Assembly RPI	>= 50 msec
Input Assembly	150
Input Assembly Size	72 bytes
Input Assembly RPI	>= 50 msec
Configuration Assembly ¹	100
Configuration Assembly Size ²	68 bytes

1. If no configuration data is to be transferred to the device, set the configuration assembly ID to 0 with a data length of 0.

2. All field values in the configuration assembly data must have valid values or the assembly data will be rejected along with the connection open request.

3. The terms Input/Output are relative to the Master/Controller

Class 3 Connection (Acyclic I/O)

The AMF Series EtherNet/IP™ devices support Class 3 connections. See Section 6 for details on supported objects and attribute definitions in the device.

Commonly Configured Attributes

EtherNet/IP™ provides several ways to configure a device. As noted in the previous sections, a configuration assembly can be used when establishing Class 1 connections, or alternatively, Class 3 connections can be used to set/get individual parameters.

ODVA also defines Electronic Data Sheets (EDS) that specify the connections and parameters that are available in the device. The AMF Series EtherNet/IP™ device has EDS files available on the Brooks Instrument website. Your EIP network configuration tool may be able to read EDS files directly to facilitate the configuration process.

The AMF Series Ethernet/IP™ devices also contains an embedded web interface for configuration and troubleshooting. To access the web-based interface, see section 'TCP/IP Network Configuration' in this manual.

The AMF Series MFC/MFM supports many different configurable attributes. The out-of-box defaults meet the needs of a great majority of applications, but some applications may require the device to report more information or behave differently than is configured with default settings, such as valve position, safe mode, flow and/or setpoint engineering units, etc.

This section covers the more common attributes that are configured to meet the unique needs of applications. The terms “attribute” and “parameters” can be used interchangeably and ultimately refer to the same data item within the device. The term “parameter” is widely used within the EDS paradigm whereas “attribute” is used within the ODVA specification.

The following tables will reference both the EDS Parameter name (if the configuration software utilizes the EDS sheet) and the EPATH descriptor (class-instance-attribute) for those who are writing custom or have other types of configuration interfaces.

Table 5-1: Commonly Configured Parameters

Attribute	EPATH	Default	Semantics
Flow Meter Data Units	[169-1-4]	4103 (0x1007)	See Next Section: Data Units
Flow Controller Data Units	[158-1-4]	4103 (0x1007)	See Next Section Data Units
Temperature Meter Data Units	[164-1-4]	4608 (0x1200)	See Next Section Data Units
Selected Gas Calibration	[102-0-101]	1	The instance of the Gas Calibration Class used to linearize the Flow Sensor
Valve Driver Safe State	[150-1-21]	0 (Close)	The valve will close when the device is in its Safe State
Status Alarm Mask	[184-1-61]	0x00000000	All Alarm Bits are masked
Status Warning Mask	[184-1-71]	0x00000000	All Warning Bits are masked

Data Units

The AMF Series MFC can report flow and accept setpoints in values associated to engineering units. This can simplify user interpretation of information from the device by letting the device perform the calculations necessary to interpret the flow signal from its internal sensor based upon information in the selected calibration.

Table 5-2: Configurable Data Units Attributes

Parameter	EPATH	Applicable Units Table	Default
Flow Sensor Data Units	[169-1-4]	Appendix C: Table 9-2 Volumetric Flow Units Table	Percent
Flow Totalizer Data Units	[161-1-40]	Appendix C: Table 9-5 Volume Units Table	Liters
Flow Control Data Units	[158-1-4]	Appendix C: Table 9-2 Volumetric Flow Units Table	Percent
Temperature Data Units	[164-1-4]	Appendix C: Table 9-4 Temperature Units	deg C

Safe Mode

All products in the AMF Series product line employs an internal State Machine to govern the operational mode of the device. One particular operational mode is the Safe Mode (a.k.a. the Safe State). For MFC(s), Safe Mode stops the controller and forces the valve actuator to a defined state (see section Valve Safe Mode). By default, the valve actuator will be closed. The state of the actuator in Safe Mode can be configured in the Valve Actuator object, parameters [150-1-21] and [150-1-22].

The device will be in Safe Mode when any of the following conditions exist:

- If any Error Status bit is set [184-1-50]
- If no Class 1 exclusive owner connection is active
- If the Class 1 exclusive owner connection is closed or times out
- If a Class 1 exclusive owner connection is active and the Run/Idle flag is set to Idle¹

Valve Safe Mode

The valve safe mode is the state the valve actuator will be in when the device is in Safe Mode. To configure the safe mode of the valve, use attribute 'Actuator Safe State' in the Valve Driver Object [150-1-21].

Table 5-3: Safe State

Value	State
0	Closed (default)
1	Open
2	Hold
3	Use Safe Value

¹ The Class 1 Exclusive Owner connection message to the target device contains a header with certain flags required by the target device for proper operation. One of these flags is the Run/Idle flag. Setting of the Run/Idle flag is a function of the master/controller software. Consult your specific master/controller tools for setting this flag. One example would be changing the run mode of a PLC (run mode or program mode) would set/clear this flag. If the Run/Idle flag is set to Run, the device will be in the Executing State, otherwise the device will be in the Safe Mode.

Process Gas Page Configuration

If the MFC/MFM contains multiple calibrations, the selection of a particular calibration can be configured in attribute 'Calibration Instance' of the Flow Meter Class [169-1-35].

The value of this attribute is limited to the number of Flow Calibration Classes configured in the device. The minimum value is 1, which is also the default value.

Additionally, the calibration can be selected using the Calibration Instance field in Output Assembly Instance 100. A value of 0 in this field is ignored by the device. If the field is set to an invalid value, calibration will not change and the 'Invalid Cal Page Selected' alarm status will be set.

Class 1 Connections

The following tables describe the available Class 1 connection configurations in the device. See section 'Data Assemblies' for assembly sizes and details on the data fields within each assembly.

MFC/MFM

Table 5-4: MFC Class 1 Connection Configuration

Name	Connection Type	Configuration Assembly	Output ¹ Assembly	Input ¹ Assembly
Exclusive Owner (XO)	Exclusive Owner	-	110	150
Input Only (IO)	Input Only	-	238	150
Exclusive Owner (XO) w/ Config	Exclusive Owner	100	110	150
Input Only (IO) w/ Config	Input Only	100	238	150

¹ The terms Input/Output are relative to the Controller/Master.

Note: Gas Calibration Class Instance

The value of this attribute is limited to the number of Process Gas Class instances configured in the device. The minimum value is 1, which is also the default value.

Data Assemblies**Configuration Assembly**

The configuration assembly can be used to get or set configuration values in the device. Depending on the application tools for the master scanner, this configuration data can be sent to the device when Class 1 connections are created with the device. If the configuration data is sent to the device using this assembly, all the data fields in the assembly must be a valid value otherwise all the data will be rejected. Refer to the class definitions for more information on each parameter in this assembly.

Configuration Assembly Instance ID: 100**Device Type: MFC****Assembly Size: 88 Bytes / 22 Words***Table 5-5: MFC Configuration Assembly Definition*

Parameter	Class	Inst	ID	Data Type	Byte Offset	Data Size	Description
Flow_Units	169	1	4	UDINT	0	4	Flow Meter Units
Ctrl_Units	158	1	4	UDINT	4	4	Flow Controller Units
Flow_Total_Units	161	1	40	UDINT	8	4	Totalizer Units
Temp_Units	164	1	4	UDINT	12	4	Temperature Meter Units
Flow_Alarm_TP_High	169	1	17	REAL	16	4	High Flow Alarm Trip Point
Flow_Alarm_TP_Low	169	1	18	REAL	20	4	Low Flow Alarm Trip Point
Flow_Alarm_Hyst	169	1	19	REAL	24	4	Flow Alarm Hysteresis
Flow_Alarm_On_Delay	169	1	20	UDINT	28	4	Flow Alarm On Delay
Flow_Alarm_Off_Delay	169	1	28	UDINT	32	4	Flow Alarm Off Delay
Flow_Warn_TP_High	169	1	21	REAL	36	4	High Flow Warning Trip Point
Flow_Warn_TP_Low	169	1	22	REAL	40	4	Low Flow Warning Trip Point
Flow_Warn_Hyst	169	1	23	REAL	44	4	Flow Warning Hysteresis
Flow_Warn_On_Delay	169	1	24	UDINT	48	4	Flow Warning On Delay
Flow_Warn_Off_Delay	169	1	27	UDINT	52	4	Flow Warning Off Delay
Bk_Stream_Flow_Lim	169	1	174	REAL	56	4	Back Stream Flow Limit
Bk_Stream_On_Delay	169	1	175	UDINT	60	4	Back Stream Settling Time
No_Flow_Lim	158	1	160	REAL	64	4	No Flow Limit Threshold
No_Flow_On_Delay	158	1	161	UDINT	68	4	No Flow Settling Time Threshold
Safe_State	150	1	21	UDINT	72	4	Valve Safe State
Safe_Value	150	1	22	REAL	76	4	Valve Safe Value
Alarms_Mask	184	1	61	DWORD	80	4	Alarm Bits Mask
Warnings_Mask	184	1	71	DWORD	84	4	Warning Bits Mask

Configuration Assembly Instance ID: 100

Device Type: MFM

Assembly Size: 68 Bytes / 17 Words

Table 5-6: MFM Configuration Assembly Definition

Parameter	Class	Inst	ID	Data Type	Byte Offset	Data Size	Description
Flow_Units	169	1	4	UDINT	0	4	Flow Meter Units
Flow_Total_Units	161	1	40	UDINT	4	4	Totalizer Units
Temp_Units	164	1	4	UDINT	8	4	Temperature Meter Units
Flow_Alarm_TP_High	169	1	17	REAL	12	4	High Flow Alarm Trip Point
Flow_Alarm_TP_Low	169	1	18	REAL	16	4	Low Flow Alarm Trip Point
Flow_Alarm_Hyst	169	1	19	REAL	20	4	Flow Alarm Hysteresis
Flow_Alarm_On_Delay	169	1	20	UDINT	24	4	Flow Alarm On Delay
Flow_Alarm_Off_Delay	169	1	28	UDINT	28	4	Flow Alarm Off Delay
Flow_Warn_TP_High	169	1	21	REAL	32	4	High Flow Warning Trip Point
Flow_Warn_TP_Low	169	1	22	REAL	36	4	Low Flow Warning Trip Point
Flow_Warn_Hyst	169	1	23	REAL	40	4	Flow Warning Hysteresis
Flow_Warn_On_Delay	169	1	24	UDINT	44	4	Flow Warning On Delay
Flow_Warn_Off_Delay	169	1	27	UDINT	48	4	Flow Warning Off Delay
Bk_Stream_Flow_Lim	169	1	174	REAL	52	4	Back Stream Flow Limit
Bk_Stream_On_Delay	169	1	175	UDINT	56	4	Back Stream Settling Time
Alarms_Mask	184	1	61	DWORD	60	4	Alarm Bits Mask
Warnings_Mask	184	1	71	DWORD	64	4	Warning Bits Mask

Output Assemblies

These assemblies are used to send data to the device. From the master scanner perspective these are outputs. Each assembly is defined to be used with a certain type of connection: Exclusive Owner and Input Only. See Appendix A for more information on connection types. Refer to the object definitions for more information on parameter in this assembly.

Process Control 1**Assembly Instance ID: 110****Device Type: MFC****Assembly Size: 28 Bytes / 7 Words***Table 5-7: MFC Process Control 1 Assembly*

Parameter	Class	Inst	ID	Data Type	Byte Offset	Data Size	Description
Ctrl_Setpoint	158	1	6	REAL	0	4	Flow Control Setpoint
Valve_Override	150	1	5	DINT	4	4	Valve Override Command
Ctrl_Override	158	1	5	DINT	8	4	Control Mode
Fixed_Ctrl_Value	158	1	159	REAL	12	4	Fixed Control Mode Value
Cust_Flow_Total_Ctrl	169	1	200	DINT	16	4	Custom Flow Totalizer Control
Cal_Instance	102	0	101	DINT	20	4	Calibration Instance
Zero_Enable	162	1	125	UDINT	24	4	Zero Operation Enable

Process Control 1**Assembly Instance ID: 110****Device Type: MFM****Assembly Size: 12 Bytes / 3 Words***Table 5-8: MFM Process Control 1 Assembly*

Parameter	Class	Inst	ID	Data Type	Byte Offset	Data Size	Description
Cust_Flow_Total_Ctrl	169	1	200	DINT	0	4	Custom Flow Totalizer Control
Cal_Instance	102	0	101	DINT	4	4	Calibration Instance
Zero_Enable	162	1	125	UDINT	8	4	Zero Operation Enable

Null Data**Instance ID: 238****Device Type: MFC/MFM****Assembly Size: 0 Bytes / 0 Words****Assembly Definition**

Null Data assemblies are used for Listen Only or Input Only connections where no data is sent to the device, but an endpoint assembly must be defined when the connection is established.

Input Only Outputs and Inputs

Assembly Definition

Dummy Data assemblies are used for Input Only connections where dummy data is sent to the device, but an endpoint assembly must be defined when the connection is established. The value of the dummy data is ignored by the device.

Although the assembly size is 6 bytes, when using DeltaV™ with a PK Controller, the output size in DeltaV™ needs to be configured for 0 bytes because the PK Controller pads the data to become 6 bytes, at the time of publication of this manual. DeltaV™ and the PK Controller are Emerson products. Please contact Emerson with any questions about their configuration.

Input Assemblies

These assemblies are used to retrieve data from the device. From the scanner perspective these are inputs. Each assembly is defined to be used with a certain type of connection: Exclusive Owner, and Input Only. See Appendix A for more information on connection types. Refer to the object definitions for more information on parameter in this assembly.

Process Data - MFC

Instance ID: 150

Device Type: MFC

Assembly Size: 88 Bytes / 22 Words

Table 5-9: MFC Process Data Assembly

Parameter	Class	Inst	ID	Data Type	Byte Offset	Data Size	Description
Flow	169	1	6	REAL	4	4	Flow Sensor Value
Flow_Units	169	1	4	UDINT	8	4	Sets the Engineering Units of 'Flow' and other related attributes in this class
Valve_Drive	150	1	6	REAL	12	4	Valve Actuator Position
Valve_Override	150	1	5	REAL	16	4	Current valve override mode
Ctrl_Setpoint	158	1	6	REAL	20	4	Current setpoint value
Ctrl_Units	158	1	4	UDINT	24	4	Sets the Data Type of 'Ctrl_Setpoint' and related attributes in this class
Temperature	164	1	6	REAL	28	4	Temperature sensor value
Temp_Units	164	1	4	UDINT	32	4	Sets the Data Type of 'Temperature' and related attributes in this class
Active_Alarms	184	1	60	DWORD	36	4	Active Alarms
Active_Warnings	184	1	70	DWORD	40	4	Active Warnings
Active_Errors	184	1	50	DWORD	44	4	Active Errors
Device_Status	184	1	80	DWORD	48	4	Device Status
Flow_Totalizer	161	1	41	REAL	52	4	Flow sensor totalizer
Cust_Flow_Total	161	1	42	REAL	56	4	Customer flow sensor totalizer - controllable by customer
Flow_Total_Units	161	1	40	UDINT	60	4	The Engineering Units used to report totalizer values

Table 5-9: MFC Process Data Assembly (Cont.)

Total_Flow_Hours	161	1	6	REAL	64	4	Total hours of flow through flow sensor
Cal_Instance	102	0	101	DINT	68	4	The selected Process Gas page selected for the flow sensor
PG_ID	102	Active Instance	2	DINT	72	4	Numeric identifier of the process gas
PG_Full_Scale	102	Active Instance	3	REAL	76	4	Full scale range of the selected process gas page
PG_Data_Units	102	Active Instance	7	DINT	80	4	Data Units associated with this process gas page
Supply_V	100	1	190	REAL	84	4	External power supply voltage
Supply_A	100	1	185	REAL	88	4	External power supply current

Process Data - MFM**Instance ID: 150****Device Type: MFM****Assembly Size: 72 Bytes / 18 Words**

Table 5-10: MFM Detailed Process Monitoring Assembly

Parameter	Class	Inst	ID	Data Type	Byte Offset	Data Size	Description
Flow	169	1	6	REAL	4	4	Flow Sensor Value
Flow_Units	169	1	4	UDINT	8	4	Sets the Engineering Units of 'Flow' and other related attributes in this class
Temperature	164	1	6	REAL	12	4	Temperature sensor value
Temp_Units	164	1	4	UDINT	16	4	Sets the Data Type of 'Temperature' and related attributes in this class
Active_Alarms	184	1	60	DWORD	20	4	Active Alarms
Active_Warnings	184	1	70	DWORD	24	4	Active Warnings
Active_Errors	184	1	50	DWORD	28	4	Active Errors
Device_Status	184	1	80	DWORD	32	4	Device Status
Flow_Totalizer	161	1	41	REAL	36	4	Flow sensor totalizer
Cust_Flow_Total	161	1	42	REAL	40	4	Customer flow sensor totalizer - controllable by customer
Flow_Total_Units	161	1	40	UDINT	44	4	The Engineering Units used to report totalizer values
Total_Flow_Hours	161	1	6	DINT	48	4	Total hours of flow through flow sensor
Cal_Instance	169	1	35	DINT	52	4	The selected Process Gas page selected for the flow sensor
PG_ID	102	Active Instance	2	DINT	56	4	Numeric identifier of the process gas
PG_Full_Scale	102	Active Instance	3	REAL	60	4	Full scale range of the selected process gas page
PG_Data_Units	102	Active Instance	7	DINT	64	4	Data Units associated with this process gas page
Supply_V	100	1	190	REAL	68	4	External power supply voltage
Supply_A	100	1	185	REAL	72	4	External power supply current

Overview

This section is recommended for advanced users of EtherNet/IP™ and Brooks Instrument MFC/ MFM products.

This section details all the Classes, Instances, Attributes and Services supported by the AMF Series MFC/MFM. Differences between the MFC and MFM device types are noted as exceptions in each subsection. The classes detailed in the following sections can be categorized into the following functional groups to indicate what aspect of the device is being configured:

Table 6-1: Accessible Classes

Class	ID	Instances	MFC	MFM
Identity Class	1 (0x01)	1	Y	Y
Flow Sensor Class	162 (0xA2)	1	Y	Y
RTB Class	161 (0xA1)	1	Y	Y
Assembly Class	4 (0x04)	4	Y	Y
Device Management Class	100 (0x64)	1	Y	Y
Process Gas Class	102 (0x66)	1-6, depending on the number of calibrations stored in the device	Y	Y
Value Driver Class	150 (0x96)	1	Y	N/A
Flow Controller Class	158 (0x9E)	1	Y	N/A
Temperature Meter Class	164 (0xA4)	1	Y	Y
Flow Meter Class	169 (0xA9)	1	Y	Y
Status Class	184 (0xB8)	1	Y	Y

In the ODVA specification, Instance 0 of both attributes and services are referred to as Class Level attributes and services. Instance 1 and higher are referred to as Instance Level attributes and services. This document will refer to all Levels by their instance number to avoid possible confusion.

The following details the meaning of the table heading names:

Attribute ID: The ID number of the attribute.

Name: The ODVA Specification label for the attribute.

Data Type: The ODVA Data Type for this attribute. See Appendix B for the definition of each data type.

Access Rule: “Get” means that the value of this attribute is “ReadOnly”. “Set” means that the value of this attribute can be read and/or written.

NV: “NV” = The value of the attribute is stored in non-volatile memory and its value will be retained after a power cycle.

V: “V” = The value of the attribute is in volatile memory and its value will be returned to default after a power cycle.

Description: A brief description of the meaning of the attribute.

Notes: Any additional notations of importance about the attribute. These notes will be found in the same section as the table.

Services

Services are operations or functions that can be invoked against a class. Services are invoked using Class 3 messaging (request/response). The services list in the table below are supported for all the classes defined in this document. Other services specific to a class are included with the class description.

Table 6-2: Common Services for all Classes

Service Code	Service Name	Service Description	Details
0x0E	Get Attribute Single	Returns the contents of the specified attribute	Appendix D: Get Attribute Single
0x10	Set Attribute Single	Writes the contents of the specified attribute	Appendix D: Set Attribute Single

Identity Class [0x01]

Device Type(s): MFC and MFM
 The Identity Class contains informational attributes that uniquely describe the device.

Example:

The use of attributes Vendor ID, Device Type, Product Code, and Serial Number together uniquely describe this device from any other device.

Attributes

Table 6-3: Identity Instance Attributes

Attrib ID	Name	Data Type	Access Rule	NV	Description	Notes
1	Vendor ID	UINT	Get	NV	ID Number assigned to Vendor by ODVA.	Brooks Instrument ID = 246
2	Device Type	UINT	Get	NV	Numeric identifier indicating the ODVA Device Profile implemented by the device.	Device Type = 43 (0x2B) See 'Note: Device Type' below
3	Product Code	UINT	Get	NV	Identification of a product of an individual vendor.	MFC = 7416, MFM = 7417
4	Revision	STRUCT of:	Get	NV	Revision of the device the Identity Object represents.	See 'Note: Revision' below
	Major Revision	USINT				
	Minor Revision	USINT				
5	Status	WORD	Get	V	Summary status of the device.	See 'Note: Status' below
6	Serial Number	UDINT	Get	NV	Serial number of the device.	See 'Note: Serial Number' below
7	Product Name	SHORT STRING	Get	NV	Human readable Identification.	

Note: Device Type

The device profile includes both an Identity and the Device Management Classes. Both objects contain an attribute that defines the kind of device this implementation supports. In this class the Device Type is assigned a numeric value of 0x2B. This number corresponds to the device profile ID contained in the ODVA specification. This attribute should not be confused with the Device Manager Device Type attribute [100-1-1] which is represented as a STRING (Short String) data type.

Note Revision

The ODVA specification defines Major Revision as a significant change to the fit, form, or function of the product. Minor Revision is defined as changes that do not affect user configuration choices such as bug fixes, hardware component change, labeling change, etc.

Note Status

The Status attribute of the Identity Class represents a summary status of the entire device. The definition of each bit in this attribute is defined by the ODVA EtherNet/IP™ specification. The Status Class (184) provides detailed status of the operation of the MFC.

Table 6-4: Identity Class Status

Bit	Label	Description
0	Owned	A Value of (1) indicates a Class 1 connection of type Exclusive Owner has been established with the device. Otherwise, this bit will have a value of (0)
1-7	Reserved	Always 0
8	Minor Recoverable Fault	One or more Warning Status bits are set in the Status Class (184) attribute (5)
9	Reserved	Always 0
10	Major Recoverable Fault	One or more Alarm Status bits are set in the Status Class (184) attribute (4)
11	Major Unrecoverable Fault	One or more Error Status bits are set in the Status Class (184) attribute (3)
12-15	Reserved	Always 0

Note: Serial Number

This Serial Number attribute differs from the Device Manager Serial Number attribute [100-1-9] whereby the Identity Class attribute [1-1-6] is strictly a numeric value that is guaranteed to be unique by the manufacturer across all ...the manufacturer's products. The Device Manager attribute 'Serial Number' is a string value that should represent the manufacturer's method of defining serial numbers for its products.

Services

Reset

Table 6-5: Identity Class Reset Service

Service Code	Service Name	Service Description
0x05	Reset	Resets the device (similar to cycling power)

Table 6-6: Identity Class Reset Service Parameters

Parameter Name	Data Type	Required	Parameter Value	Semantics
Reset Type	USINT	N	0	Emulate as closely as possible cycling power on the item the Identity Class represents. This value is the default if this parameter is omitted (default).
			1	Return as closely as possible to the out-of-box configuration, then as closely as possible emulate cycling power.
			2	Return as closely as possible to the out-of-box configuration with the exception of communication link parameters and emulate cycling power as closely as possible

Table 6-7: Identity Class Reset Service Response

Parameter Name	Data Type	Required	Parameter Value	Semantics
NO RESPONSE DATA				

Assembly Class [0x04]

Device Type(s): MFC and MFM

The Assembly Class contains a list of attributes that data can be written to (sink) and read from (source) via the Data Buffer (3) attribute contained in this object. The Assembly Class is generally assigned as the endpoint of an I/O Connection object (assigned via the Path attributes in the Connection Class). In this way, multiple pieces of data can be moved to and from the device with a reduced number of network messages. Assembly definitions supported by AMF Series MFC/MFM are defined in Section 5, 'Data Assemblies.'

Attributes

Table 6-8: Assembly Class Instance Attributes

Attrib ID	Name	Data Type	Access Rule	NV	Description	Notes
3	Data Buffer	ARRAY of BYTE	Conditional	NV	Zero or more attributes that comprise the Data Buffer	If the assembly is used as an endpoint in an active Class 1 connection, then this attribute will be Get only. Writing to this attribute will return a Device State conflict error

Services

No Class Specific Services

Device Manager Class [0x64]

Device Types: MFC and MFM

The Device Manager Class contains product information about the AMF Series MFC/MFM device such as serial number, model number, firmware revisions, etc. The class also captures device level operational parameters not specific to any other application object defined in the device.

Attributes

Table 6-9: Device Manager Instance Attributes

Attrib ID	Name	Data Type	Access Rule	NV	Description
1	Dev_Type	SHORT_STRING	GET	NV	Device type label
3	Mfr_Name	SHORT_STRING	GET	NV	Manufacturer's Name
4	Mfr_Model	SHORT_STRING	GET	NV	Manufacturer's Model Number
5	Main_Brd_FW_Rev	SHORT_STRING	GET	NV	Revision of the Main Board Firmware
6	Main_Brd_HW_Rev	SHORT_STRING	GET	NV	Revision of the Main Board Hardware
7	Ser_No	SHORT_STRING	GET	NV	Device Serial Number
8	Dev_Cfg	SHORT_STRING	GET	NV	Device Configuration
103	Main_Brd_BL_Rev	SHORT_STRING	GET	NV	Revision of the Main Board Bootloader
190	Supply_V	REAL	GET	V	External power supply voltage
185	Supply_A	REAL	GET	V	External power supply current
191	Supply_V_Min_Limit	REAL	SET	NV	Low Voltage threshold that will raise a Supply Volts Low warning status
192	Supply_V_Max_Limit	REAL	SET	NV	High Voltage threshold that will raise a Supply Volts High warning status
193	Supply_V_Settle_Time	UDINT	SET	NV	The amount of time the warning condition must exist before the warning status is raised. This settling time is also applied when the condition transitions from warning to nominal
250	Comm_Brd_FW_Rev	SHORT_STRING	GET	NV	Revision of the Adapter Board Firmware
251	Comm_Brd_HW_Rev	SHORT_STRING	GET	NV	Revision of the Adapter Board Hardware
252	Comm_Brd_BL_Rev	SHORT_STRING	GET	NV	Revision of the Adapter Board Bootloader
220	In_Safe_State	UDINT	SET	V	Moves the device in or out of safe state 0: Out of Safe State, 1: In Safe State

Note: Status

Status bits associated with this class are listed below. See section 7 for details on specific status and behavior.

- **[Active_Warnings]{184-1-5}, Bit 26:** Power Supply Warning (Low or High)

Note: Revision Level

Attributes representing firmware revisions running in the device are comprised of the major, minor, minor-minor revision level format (ex: xx.xx.xx).

Note: Supply Voltage

The Device Manager Class reports the input supply voltage to device. Warning status bits (See Status Class section) can be used to indicate high or low input voltage condition. Setting attributes 191 and 192 configures the threshold values for raising the status flags. The statuses are self-clearing when the voltage returns within nominal range. Attribute 193 can be configured to delay the raising or clearing of the status to minimize spurious indications.

Services

No Class Specific Services

Flow Sensor Class [0xA2]

Device Types: MFC and MFM

Attributes

Table 6-10: Flow Sensor Instance Attributes

Attrib ID	Name	Data Type	Access Rule	NV	Description
120	Zero_Op_Duration	UDINT	SET	NV	The amount of time to used by the device to perform a device zero operation
125	Zero_Op_Enable	UDINT	SET ONLY	-	Starts the device zero operation
193	Zero_Success_Band	REAL	SET	NV	The error band for which the 'Bad_Zero_Warning' status will be set if, after completion of a zero operation, the resulting zero exceeds this band.
194	Zero_Min_Drift_Time	UDINT	SET	NV	The minimum time limit between two successful zero operations that must occur before an excessive zero drift diagnostic will be run.
195	Excessive_Drift_Rate	REAL	SET	NV	A unit-less factor to set the maximum allowed zero drift rate
197	Total_Drift	REAL	GET	NV	The total zero drift since attribute 'Cal_Instance' was changed

Services

No Class Specific Services

Flow Meter Class [0xA9]

Device Types: MFC and MFM

The Flow Meter Class is responsible for reporting flow values and configuring flow-related statuses. The Flow Meter Class in conjunction with the selected Gas Calibration Class can linearize the sensor values and convert measurements into engineering data units.

Attributes

Table 6-11: Flow Meter Instance Attributes

Attrib ID	Name	Data Type	Access Rule	NV	Description
4	Flow_Units	UDINT	SET	NV	Sets the Engineering Units of 'Flow' and other related attributes in this class
6	Flow	REAL	GET	V	Flow Sensor value
17	Flow_Alarm_TP_High	REAL	SET	NV	The 'Flow' threshold above which an 'Active_Alarms_High_Flow' status will occur
18	Flow_Alarm_TP_Low	REAL	SET	NV	The 'Flow' threshold below which an 'Active_Alarms_Low_Flow' status will occur
19	Flow_Alarm_Hyst	REAL	SET	NV	The amount by which 'Flow' must recover past the Trip Point threshold (attributes 17 or 18) to clear the associated status condition
20	Flow_Alarm_On_Delay	UDINT	SET	NV	The time that 'Flow' must exceed the Alarm Trip Point thresholds (High or Low) before the Status Condition is raised.
21	Flow_Warn_TP_High	REAL	SET	NV	The 'Flow' threshold above which an 'ActiveWarnings_High_Flow' status will occur
22	Flow_Warn_TP_Low	REAL	SET	NV	The 'Flow' threshold below which an 'ActiveWarnings_Low_Flow' status will occur
23	Flow_Warn_Hyst	REAL	SET	NV	The amount by which 'Flow' must recover past the Trip Point threshold (attributes 21 or 22) to clear the associated status condition
24	Flow_Warn_On_Delay	UDINT	SET	NV	The time that 'Flow' must exceed the Warning Trip Point thresholds (High or Low) before the Status Condition is raised.
27	Flow_Warn_Off_Delay	UDINT	SET	NV	The time that 'Flow' has recovered from the Warning Trip Point threshold +/- Warning hysteresis before the associated status condition is cleared
28	Flow_Alarm_Off_Delay	UDINT	SET	NV	The time that 'Flow' has recovered from the Alarm Trip Point threshold +/- Alarm hysteresis before the associated status condition is cleared
160	Zero_Warn_On_Delay	UDINT	SET	NV	The number of seconds after 0% setpoint that the device will delay before checking quality of zero.
161	Zero_Warn_Band	REAL	SET	NV	The error band for which the 'Zero_Recommended' status will be set if the quality of the zero exceeds this band. A value of 0 disables this diagnostic.

Table 6-11: Flow Meter Instance Attributes (Cont.)

174	Bk_Stream_ Flow_Lim	REAL	SET	NV	The threshold by which reverse flow must exceed for 'Bk_Stream_Time_Lim' until a 'Back_Streaming_Error' is raised.
175	Bk_Stream_On_ Delay	UDINT	SET	NV	The minimum time flow exceeds 'Back_Strem_Flow_Lim' until a 'Back_Streamin_Error' is raised.

Note: Data Units

The value of this attribute is limited to the values specified in the Volumetric Flow Units Table in Appendix C - Data Units.

Note: Status

Status bits associated with this object are listed below. See section 7 for details on specific status and behavior.

- **[Active_Errors]{184-1-3}, Bit 2:** Back Streaming Error
- **[Active_Alarms]{184-1-4}, Bit 0:** Low Flow Alarm
- **[Active_Alarms]{184-1-4}, Bit 1:** High Flow Alarm
- **[Active_Alarms]{184-1-4}, Bit 2:** No Flow Alarm
- **[Active_Alarms]{184-1-4}, Bit 3:** Choked Flow Alarm
- **[Active_Alarms]{184-1-4}, Bit 15:** Invalid Process Gas Page Selected
- **[Active_Warnings]{184-1-5}, Bit 0:** Low Flow Warning
- **[Active_Warnings]{184-1-5}, Bit 1:** High Flow Warning
- **[Active_Warnings]{184-1-5}, Bit 3:** Choked Flow Warning
- **[Active_Warnings]{184-1-5}, Bit 4:** Excessive Zero Drift Warning
- **[Active_Warnings]{184-1-5}, Bit 5:** Bad Zero Warning
- **[Active_Warnings]{184-1-5}, Bit 17:** Calibration Due
- **[Active_Warnings]{184-1-5}, Bit 18:** Totalizer Overflow
- **[Active_Warnings]{184-1-5}, Bit 19:** Overhaul Due

Services

No Class Specific Services

RTB Class [0xA1]

Device Types: MFC and MFM

Attributes

Table 6-12: RTB Class Instance Attributes

Attrib ID	Name	Data Type	Access Rule	NV	Description
6	Total_Flow_Time	REAL	GET	NV	Total seconds of flow through flow sensor
11	Overhaul_Due_Hours	UDINT	SET	NV	The time remaining in hours until device requires service. When this timer reaches 0, Overhaul Due Warning status shall be set
21	Cal_Due_Hours	UDINT	SET	NV	The time remaining in hours until the device needs to be recalibrated. When this timer reaches 0, Calibration Due Warning status shall be set
40	Flow_Total_Units	UDINT	SET	NV	The Engineering Units used to report totalizer values
41	Flow_Totalizer	REAL	GET	NV	Total gas flowed through the device
42	User_Flow_Total	REAL	GET	NV	Total gas flowed through the device since the last commanded reset through attribute 'Cust_Flow_Total_Ctrl' (attribute 200)
200	User_Flow_Total_Ctrl	DINT	SET ONLY	V	Controls 'Cust_Flow_Total' (attribute 130)

Note: Totalizers

There are two totalizers: Flow Totalizer [126] and Custom Flow Totalizer [130]. The behavior of each totalizer is described in the following sections. The units of measure for both totalizers are set using Totalizer Units [125]. See Appendix C – Volume Flow Units table.

Flow Totalizer

Flow Totalizer [126] is a count-up flow totalizer. The attribute can be set to any value. If this totalizer value exceeds Totalizer Overflow Threshold [230], status Active_Warnings_Totalizer_Overflow {184-1-5} will be set. Setting this totalizer value below the overflow threshold will clear the status.

Custom Flow Totalizer

Custom Flow Totalizer [130] is a count-up flow totalizer. This totalizer value is controlled by Custom Flow Totalizer Control [131]. Options for controlling the totalizer are Run (1), Stop (2), and Reset (3). Reading Custom Flow Totalizer Control [131] will return the current operational state of the timer: Run (1) or Stop (2). When the Reset (3) command is written to Custom Flow Totalizer Control [131], the totalizer will reset to zero, and then return to its operational state prior to writing the reset command.

Note: Timers

There are two countdown timers, Overhaul Due [226] and Calibration Due [227], and one count-up timer Power On Hours [222].

Countdown Timers

Overhaul Due [226] and Calibration Due [227] are countdown timers. These timers can be utilized to raise preventative maintenance and calibration events. Counting down commences when the device is flowing gas. When the counters reach zero, their respective status' [Active_Alarms_Overhaul_Due] [184-1-5], and [Active_Alarms_Calibration_Due] [184-1-5] will be set. Writing a non-zero value to these timers will clear their respective status'. These timers can be written to at any time.

Count-Up Timers

Power On Hours [222] is a count-up timer that represents the total time, in hours, that the device has been powered on. This timer is not resettable.

Services

No Class Specific Services

Valve Driver Class [0x96]

Device Types: MFC

The Valve Driver is responsible for management of the actuator device controlling the process.

Attributes

Table 6-13: Valve Driver Class Instance Attributes

Attrib ID	Name	Data Type	Access Rule	NV	Description
5	Valve_Override	UDINT	SET	V	Sets an override condition for the physical actuator.
6	Valve_Position	REAL	GET	V	Physical actuator position
18	Valve_Warn_TP_High	REAL	SET	NV	Sets the threshold above which if 'Valve_Position' exceeds will raise the 'Active_Warnings_Valve_High' status to be raised
19	Valve_Warn_TP_Low	REAL	SET	NV	Sets the threshold below which if 'Valve_Position' exceeds will raise the 'Active_Warnings_Valve_Low' status to be raised
20	Valve_Warn_Hyst	REAL	SET	NV	Sets the amount by which 'Valve_Position' must recover past the threshold (see attributes 18 & 19) to clear the associated status condition
21	Valve_Safe_State	UDINT	SET	NV	The position the actuator will go to when the device is not in executing state (Device_Status_Device_Exec = 0), otherwise known as the device safe state
22	Valve_Safe_Value	REAL	SET	NV	If 'Safe_State' is set to 'use Safe_Value', this attribute sets the actuator position if the actuator shall move to when the device is in the safe state

Note: Override

The following table outlines the valid actuator override types

Table 6-14: Override

Value	State	Description
0	Normal	Actuator is under normal operational control
1	Closed	Actuator is driven fully closed
2	Open	Actuator is driven fully open
3	Hold	Actuator is held to last updated analog output signal prior to assertion of override
4	Safe Value	Actuator is driven to the condition specified by the Safe Value [22] attribute

Note: Valve

To interpret the value of this attribute, it is important to understand the following terms:

Operational Range:

This is the range that is reported by Value [6]. The operational range of the actuator is full range that the actuator can be driven to move. This corresponds to Value [6] values of 0 to 100%.

Nominal Control Range:

The nominal control range is a set of values that the actuator is driven to that maps directly between no flow and full-scale flow. This set of values is a subrange within the large operational range of the actuator. Example, the nominal control range for a 0 to 100 SCCM device flowing nitrogen could be as follows:

at 0 SCCM Actuator = 20%
at 100 SCCM, Actuator = 30%

Under normal operational control (no override), the actuator generally operates in the nominal control range. The upper end of the control range is not an absolute limit under normal control. The controller will drive the actuator to whatever value is necessary to control flow. For example, if a restriction occurred upstream of the device resulting in reduced supply to the device, the controller will drive the actuator beyond the nominal control range to maintain control.

Status

Status bits associated with this object are listed below. For details, see Section 7.

- **[Active_Warnings]{184-1-5}, Bit 8:** Valve High Warning
- **[Active_Warnings]{184-1-5}, Bit 9:** Valve Low Warning
- **[Active_Warnings]{184-1-5}, Bit 10:** Valve Control Warning

Safe State

The following table outlines valid values for this attribute. This table applies for normally closed and normally open valves.

Table 6-15: Safe State

Value	State	Description
0	Closed	The actuator will be driven closed (0%)
1	Open	The actuator will be driven open (100%)
2	Hold Last Value	The actuator will be driven to the last updated value of the analog output just prior to the entering of the safe state
3	Use Safe Value	The actuator will be driven to the value configured in Safe Value [22]

Services

No Class Specific Services

Flow Controller Class [0x9E]

Device Types: MFC

The Flow Controller class is responsible for closing the loop between the measured process variable (via the Flow Meter Class) and the control variable (via the Valve Drive Class).

Attributes

Table 6-16: Flow Controller Class Instance Attributes

Attrib ID	Name	Data Type	Access Rule	NV	Description
4	Ctrl_Units	UDINT	SET	NV	Sets the Data Type of 'Ctrl_Setpoint' and related attributes in this class See CIP Specification Vol. 1, Appendix D for a list of values. A request to set this to an unsupported value will return an error response.
5	Ctrl_Override	UDINT	SET	V	Overrides the automatic control of the flow controller
6	Ctrl_Setpoint	REAL	SET	V	The requested setpoint to which the process variable ('Flow') will be controlled
15	Ctrl_Warning_On_Delay	UDINT	SET	NV	Time allowed for the control-loop to settle to within 'Ctrl_Warn_Error_Band'.
16	Ctrl_Warn_Error_Band	REAL	SET	NV	The maximum amount flow can deviate from the commanded setpoint before raising 'Active_Warnings_SP_Deviation'. This warning is disabled if set to 0, or setpoint is 0, or in valve override, or valve in safe state
19	Ctrl_Ramp_Time	UDINT	SET	NV	The time the controller will take to move from the old setpoint to the new setpoint 0 = Disabled

Table 6-16: Flow Controller Class Instance Attributes (Cont.)

104	Ctrl_Ramp_Time_Volatile	UDINT	SET	NV	Sets the persistence of attribute CTRL_Ramp_Time 0 = Non-Volatile 1 = Volatile
159	Ctrl_Fixed_Value	REAL	SET	V	When control mode is set to Fixed (129), this value drives the valve actuator.
160	Ctrl_No_Flow_Lim	REAL	SET	NV	The threshold by which if 'Flow' does not exceed, will raise an 'Active_Alarms_No_Flow' status. A value of 0 disables this Alarm
161	Ctrl_No_Flow_On_Delay	UDINT	SET	NV	The time in which a No Flow condition must exist (defined by attribute 160) before 'Active_Alarms_No_Flow' status is raised
162	Ctrl_Choked_Flow_Warn_Limit	REAL	SET	NV	The percentage of setpoint by which if 'Flow' does not exceed will raise an 'ActiveWarnings_Choked_Flow' status is raised
163	Ctrl_Choked_Flow_Warn_On_Delay	UDINT	SET	NV	The time in which a Choked Flow condition must exist (defined by attribute 162) before 'Active_Warnings_Choked_Flow' status is raised
164	Ctrl_Choked_Flow_Warn_Off_Delay	UDINT	SET	NV	The time in which flow conditions are not at the choked flow warning limit (defined by attribute 162) before 'Active_Warnings_Choked_Flow' status is cleared
165	Ctrl_Choked_Flow_Alarm_Limit	REAL	SET	NV	The percentage of setpoint by which if 'Flow' does not exceed will raise an 'ActiveAlarms_Choked_Flow' status is raised
166	Ctrl_Choked_Flow_Alarm_On_Delay	UDINT	SET	NV	The time in which a Choked Flow condition must exist (defined by attribute 165) before 'Active_Alarms_Choked_Flow' status is raised
167	Ctrl_Choked_Flow_Alarm_Off_Delay	UDINT	SET	NV	The time in which flow conditions are not at the choked flow warning limit (defined by attribute 165) before 'Active_Alarms_Choked_Flow' status is cleared
201	Ctrl_Warn_SP_Hi	REAL	SET	NV	The threshold at which a setpoint hi warning is raised.
202	Ctrl_Warn_SP_Hi_On_Delay	UDINT	SET	NV	Delay time before asserting the warning
203	Ctrl_Warn_SP_Hi_Off_Delay	UDINT	SET	NV	Delay time before clearing the warning
204	Ctrl_SP_Lim	REAL	SET	NV	The maximum value for setpoint. If setpoint exceeds this value, a setpoint overlimit warning is raised and the setpoint will be bounded to the setpoint limit. This is disabled when set to 0.
205	Ctrl_Warn_SP_Lim_On_Delay	UDINT	SET	NV	Delay time before asserting the warning
206	Ctrl_Warn_SP_Lim_Off_Delay	UDINT	SET	NV	Delay time before clearing the warning

Note: Data Units

The value of this attribute is limited to the values specified in the Volumetric Flow Units Table and Mass Flow Units table in Appendix C - Data Units.

Note: Status

Status bits associated with this object are listed below. For details, see Section 7.

- **[Active_Warnings]{184-1-5}, Bit 11:** Setpoint Deviation
- **[Active_Warnings]{184-1-5}, Bit 13:** Setpoint Overrange
- **[Active_Warnings]{184-1-5}, Bit 14:** Setpoint Limited

Note: Control Override

Table 6-17: Control Overrides

Value	Description
0	Automatic Control
129	Control Override - Set Actuator Position to the value in attribute 'Fixed Control Value' [159]

Services

No Class Specific Services

Process Gas Class [0x66]

Device Types: MFC and MFM

The Process Gas class defines characteristics associated with linearization/compensation of the gas flow sensor.

Attributes

Table 6-18: Process Gas Instance 0 Attributes

Attrib ID	Name	Data Type	Access Rule	NV	Description	Notes
2	PG_ID	DINT	GET	NV	Gas standard ID number	
3	PG_Config_Range	REAL	GET	NV	Calibrated full scale range of the process gas in FlowUnits	
4	PG_Ref_Temp	REAL	GET	NV		
5	PG_Ref_Press	REAL	GET	NV		
7	PG_Data_Units	DINT	GET	NV	Calibrated engineering units	
14	PG_Symbol	SHORT_STRING	GET	NV	Process Gas Symbol	
101	PG_Cal_Inst	DINT	SET	NV	Sets the active Process Gas Page used to report flow Valid Range of Values: 0 thru 6 A value of 0 is quietly ignored and will clear the Invalid Gas Page Alarm status	To select instances 1 thru 6, Ctrl_Setpoint must be 0.0 Instance 1 thru 6 will be accepted if a gas page exists for that instance. If a gas page does not exist, the value will be rejected and the Invalid Gas Page Alarm status will be raised. If page exists, the gas page will be selected and the Invalid Gas Page alarm will be cleared if set.

Note: Gas Standard Number

The Gas Standard Number as defined by SEMI publication SEMI E52-0298, "Practice for Referencing Gases Used in Digital Mass Flow Controllers."

Services

No Class Specific Services

Temperature Meter Class [0xA4]

Device Type(s): MFC and MFM

The Temperature Meter class measures the temperature of the process gas.

Attributes

Table 6-19: Temperature Meter Class Instance 1 Attributes

Attrib ID	Name	Data Type	Access Rule	NV	Description
4	Temp_Units	UDINT	SET	NV	Sets the Data Type of 'Temperature' and related attributes in this class
6	Temperature	REAL	GET	V	Temperature sensor value
17	High_Temp_Warn_TP	REAL	SET	NV	Sets the 'Temperature' threshold above which an 'Active_Warnings_High_Temp' status will occur
18	Low_Temp_Warn_TP	REAL	SET	NV	Sets the 'Temperature' threshold below which an 'Active_Warnings_Low_Temp' status will occur
19	Temp_Warn_On_Delay	UDINT	SET	NV	Sets the time that 'Temperature' must exceed the Temperature High/Low Warning Trip Point thresholds before the Warning Status Condition is raised.
20	Temp_Warn_Off_Delay	UDINT	SET	NV	Sets the time that 'Temperature' has recovered from the Temperature High/Low Warning Trip Point thresholds before the associated Warnng status condition is cleared
21	High_Temp_Alarm_TP	REAL	SET	NV	Sets the 'Temperature' threshold above which an 'Active_Alarms_High_Temp' status will occur
22	Low_Temp_Alarm_TP	REAL	SET	NV	Sets the 'Temperature' threshold below which an 'Active_Alarms_Low_Temp' status will occur
23	Temp_Alarm_On_Delay	UDINT	SET	NV	Sets the time that 'Temperature' must exceed the Temperature High/Low Alarms Trip Point thresholds before the Warning Status Condition is raised.
24	Temp_Alarm_Off_Delay	UDINT	SET	NV	Sets the time that 'Temperature' has recovered from the Temperature High/Low Alarms Trip Point thresholds before the associated Warnng status condition is cleared

Status

Status bits associated with this class are listed below. For details, see section 7.

- **[Active_Alarms]{184-1-4}, Bit 24:** Temperature Sensor Fail
- **[Active_Warnings]{184-1-5}, Bit 24:** High Temperature
- **[Active_Warnings]{184-1-5}, Bit 25:** Low Temperature Services

Services

No Class Specific Services

Status Class [0xB8]

The Status Class contains all the status bits that can be indicated by the device. Details of how each status indication functions and their associated attributes for configure the status function can be reference in Section 7

Attributes

Table 6-20: Status Class Instance 1..n Attributes

Attrib ID	Name	Data Type	Access Rule	NV	Description
50	Active_Errors	DWORD	GET	V	See Active Errors table
60	Active_Alarms	DWORD	GET	V	
70	Active_Warnings	DWORD	GET	V	
80	Device_Status	DWORD	GET	V	
61	Alarms_Mask	DWORD	SET	NV	
71	Warnings_Mask	DWORD	SET	NV	

Note: Active Errors

Table 6-21: Active Error Bit Definitions

Bit(s)	Description
0	Internal Fail
1	Reserved
2	Back Streaming Error
3-7	Reserved
8	Temperature Sensor Fail
9	Flow Sensor Fail
10	Valve Drive Fail
11-17	Reserved
18	Internal Communications Error
19-22	Reserved
23	NV Memory Fail
24-31	Reserved

Note: Active Alarms

Table 6-22: Active Alarms Bit Definitions

Bit(s)	Description
0	Low Flow Alarm
1	High Flow Alarm
2	No Flow Alarm
3	Choked Flow Alarm
4	Reserved
5	High Temperature Alarm
6	Low Temperature Alarm
7	Reserved
8	Valve Low Alarm
9	Valve High Alarm
10-14	Reserved
15	Invalid Gas Page Selected
16-30	Reserved
31	Internal Comms Alarm

Note: Active Warnings

Table 6-23: Active Warnings Bit Definitions

Bit(s)	Description
0	Low Flow Warning
1	High Flow Warning
2	Reserved
3	Choked Flow Warning
4	Excessive Drift Warning
5-7	Reserved
8	Valve High Warning
9	Valve Low Warning
10	Control Deviation Warning
11	Reserved
12	Zero Prevented
13	Setpoint High
14	Setpoint Limited
15	Zero Recommended
16	Overhaul Required
17	Calibration Required
18-23	Reserved
24	High Temperature Warning
25	Low Temperature Warning
26	Power Supply Warning
27-30	Reserved
31	CPU Temperature Warning

Note: Device Status

Table 6-24: Device Status Bit Definitions

Bit(s)	Description
0	Device is Executing
1	Warming Up
2	Zeroing
3-5	Reserved
6	Valve Override Active
7	Control Override Active
8	Device Error
9	Device Alarm
10	Device Warning
11	Zero Button Disabled
12	Control Ramping

Note: Mask Bits

Active Alarms [4] and Active Warnings [5] can be masked by setting the corresponding bits in the mask attributes Alarms Mask [8] and Warnings [9]

Services

No Class Specific Services

Device Status {184-1-6}

There are four levels of status: Errors, Alarms, Warnings, and Device Status in decreasing order of severity. The corresponding tag names for the status attributes are:

- **[Active_Errors] {184-1-3}**
- **[Active_Alarms] {184-1-4}**
- **[Active_Warnings] {184-1-5}**
- **[Device_Status] {184-1-6}**

Each status word is an enumerated bitfield of type DWORD. These status bits are in the Status Class (Class ID 184) and are mapped to Assembly 150.

[Active_Alarms] {184-1-4} and **[Active_Warnings] {184-1-5}** can be masked by setting the corresponding mask attributes **[Alarms_Mask] {184-1-8}** and **[Warnings_Mask] {184-1-9}**. A value of 0 for any mask bit blocks the correspond alarm or warning bit from being indicated. A value of 1 for any mask bit will allow the alarm or warning bit to be indicated.

[Active_Errors] {184-1-3} and **[Device_Status] {184-1-6}** cannot be masked. If any bit in **[Active_Errors] {184-1-3}** is set, it will force the flow controller into the Safe State. The device will require a reset to return to normal operation. A reset of the device can be achieved through a power cycle or by sending the Reset service (Service ID 0x05) to the Identity Class (Class ID 0x01).

Bit 0: Device is Executing [Device_Status_Dev_Exec]

This status indicates the current execution state of the device

Bit Value	Description
1	Active Errors == 0 AND an Active Owing I/O Connecting is present OR Active Errors == 0 AND NO Active Owing I/O Connection AND dmSafeState == 0
0	The device is in the Safe State

Bit 1: Device is Warming Up

This status indicates device warm up time has not completed. The warm up timer is started when the device is powered on or reset.

Bit Value	Description
1	Warm Up Timer < Warm Up Time
0	Warn Up Timer >= Warm Up Time

Bit 2: Device is Zeroing

This status indicates that a device zeroing is in progress.

Bit Value	Description
1	Device is zeroing
0	Device is NOT zeroing

Bit 6: Valve Override [Device_Status_Valve_Override]

This status indicates the [Valve_Override] {150-1-5} is engaged

Bit Value	Description
1	Valve Override is Active (i.e. Off, Purge)
0	Valve Override is Normal

Bit 7: Control Override [Device_Status_Ctrl_Override]

This status indicates if any [Ctrl_Override] {158-1-5} is engaged

Bit Value	Description
1	Control Override is Active (i.e. Fixed)
0	Control Override is Normal

Bit 8: Device Error [Device_Status_Dev_Error]

This status indicates if any [Active_Error] {184-1-3} are present

Bit Value	Description
1	One or more Errors are present
0	No Errors are present

Bit 9: Device Alarm [Device_Status_Dev_Alarm]

This status indicates if any [Active_Alarm] {184-1-4} are present

Bit Value	Description
1	One or more Alarms are present
0	No Alarms are present

Bit 10: Device Warning [Device_Status_Dev_Warning]

This status indicates if any [Active_Warnings] {184-1-5} are present

Bit Value	Description
1	One or more Warnings are present
0	No Warnings are present

Bit 12: Control Ramping [Device_Status_Ctrl_Ramping]

This status indicates that the controller is ramping to the new commanded setpoint. This status becomes enabled when [Ramp_Time] {158-1-19} is set to a value other than 0

Bit Value	Description
1	The controller is ramping to the new commanded setpoint
0	The controller has reached the new commanded setpoint

Warnings {184-1-5}

Bit 0: Low Flow Warning [Active_Warnings_Low_Flow]

The status indicates a low flow warning condition exists.

This status is *disabled* when **Safe State == True**

OR

Valve Override == True (MFCs Only)

See Diagram in section Typical Status High/Low Processing for typical behavior of this status.

Bit Value	Description
1	$[\text{Flow}] \{169-1-6\} < [\text{Flow_Warn_TP_Low}] \{169-1-22\}$ <p style="text-align: center;">FOR</p> $\text{Time Period} > [\text{Flow Warn On Delay}] \{169-1-24\}$
0	$[\text{Flow}] \{169-1-6\} > ([\text{Flow_Warn_TP_Low}] \{169-1-22\} + [\text{Flow_Warn_Hyst}] \{169-1-23\})$ <p style="text-align: center;">FOR</p> $\text{Time Period} > [\text{Flow Warn Off Delay}] \{169-1-24\}$

Bit 1: High Flow Warning [Active_Warnings_High_Flow]

This status indicates a high flow warning status condition.

This status is **disabled** when **Safe State == True**

OR

Valve Override == True (MFCs Only)

See Diagram in section Typical Status High/Low Processing for typical behavior of this status.

Bit Value	Description
1	$[\text{Flow}] \{169-1-6\} > [\text{Flow_Warn_TP_High}] \{169-1-21\}$ <p style="text-align: center;">FOR</p> $\text{Time Period} > [\text{Flow Warn On Delay}] \{169-1-24\}$
0	$[\text{Flow}] \{169-1-6\} < ([\text{Flow_Warn_TP_High}] \{169-1-21\} - [\text{Flow_Warn_Hyst}] \{169-1-23\})$ <p style="text-align: center;">FOR</p> $\text{Time Period} > [\text{Flow Warn Off Delay}] \{169-1-24\}$

Bit 3: Choked Flow Warning [Active_Warnings_Choked_Flow]

This status indicates a choked flow alarm is imminent. This status is **disabled** when **any** of the following conditions exist:

- **[Choked Flow Warn Limit]{158-1-162} == 0**
- **Safe State == True**
- **[Ctrl_Setpoint] {158-1-6} = 0.0**
- **[Valve_Override] {150-1-5} != 0 (Normal)**
- **[Valve Position]{150-1-6} < 98%**

Bit Value	Description
1	$[\text{Flow}] \{169-1-6\} < ([\text{Choked Flow Warn Limit}]\{158-1-162\} * [\text{Ctrl_Setpoint}] \{158-1-6\})$ <p style="text-align: center;">FOR</p> $\text{Time Period} > ([\text{Choked Flow Warn On Delay}]\{158-1-163\})$
0	$[\text{Flow}] \{169-1-6\} >= ([\text{Choked Flow Warn Limit}]\{158-1-162\} * [\text{Ctrl Setpoint}]\{158-1-6\})$ <p style="text-align: center;">FOR</p> $\text{Time Period} > [\text{Choked Flow Warn Off Delay}]\{158-1-164\}$

This warning status is a function of Setpoint whereby the trip point is a percentage of the current setpoint.

Example: If **[Choked_Flow_Limit] = 30%**, **[Choked Flow Warn On Delay] = 10 seconds**, and the current setpoint **[Ctrl_Setpoint] = 80%**, then the status will be raised when **[Flow] < (30% * 80%)** or 24% for 10 seconds.

Bit 4: Excessive Zero Drift Warning [Active_Warnings_Zero_Drift]

This diagnostic indicates excessive yearly excessive drift rate. This diagnostic accumulates the drift from zero each time the device is zeroed. The Zero Min Drift Time is the number of device runtime hours since the last check. When the runtime > Zero Min Drift Time, the yearly drift rate is computed and compared to the Excessive Drift Rate. It is recommended that Zero Min Drift Time be set to a large value (i.e. 8760 - number of hours in a year)

This diagnostic is run when a zero operation is completed.

This diagnostic is *disabled* when [Zero_Min_Drift_Time] {162-1-195} = 0

Bit Value	Description
1	Time since Last Zero Operation > [Zero_Min_Drift_Time] {162-1-194} AND The computed yearly drift rate > [Excessive Drift Rate]{162-1-195}
0	The selected calibration gas page is changed OR [Zero_Min_Drift_Time] {162-1-194} = 0

Bit 8: Valve High Warning [Active_Warnings_Valve_High]

The status indicates the valve position has exceeded a high position threshold.

See Diagram in section Typical Status High/Low Processing for typical behavior of this status.

Bit Value	Description
1	[Valve_Position] {150-1-6} > [Valve_Warn_TP_High] {150-1-18}
0	[Valve_Position] {150-1-6} < ([Valve_Warn_TP_High] {150-1-18} + [Valve_Warn_Hyst] {150-1-20})

Bit 9: Valve Low Warning [Active_Warnings_Valve_Low]

The status indicates the valve position has exceeded a low position threshold.

See Diagram in section Typical Status High/Low Processing for typical behavior of this status.

Bit Value	Description
1	[Valve_Position] {150-1-6} < [Valve_Warn_TP_Low] {150-1-19}
0	[Valve_Position] {150-1-6} > ([Valve_Warn_TP_Low] {150-1-19} + [Valve_Warn_Hyst] {150-1-20})

Bit 11: Setpoint Deviation [Active_Warnings_SP_Deviation]

The status indicates the controller cannot control flow to within the error band within a defined settling time. This diagnostic is **disabled** when **any** of the following conditions exists:

- **[Ctrl_Setpoint] {158-1-6} = 0**
- **[Ctrl Warn Erro Band]{158-1-16} == 0**
- **Valve Override == True**
- **Safe State == True**

Bit Value	Description
1	$[\text{Flow}] \{169-1-6\} > ([\text{Ctrl_Setpoint}] \{158-1-6\} + (0.5 * [\text{Ctrl_Warn_Error_Band}] \{158-1-16\}))$ <p style="text-align: center;">OR</p> $[\text{Flow}] \{169-1-6\} < ([\text{Ctrl_Setpoint}] \{158-1-6\} - (0.5 * [\text{Ctrl_Warn_Error_Band}] \{158-1-16\}))$ <p style="text-align: center;">FOR</p> <p style="text-align: center;">Time Period > [Ctrl Warn On Delay {158-1-15}]</p>
0	$[\text{Flow} \{169-1-6\}] \leq ([\text{Ctrl_Setpoint}] \{158-1-6\} + (0.5 * [\text{Ctrl_Warn_Error_Band}] \{158-1-16\}))$ <p style="text-align: center;">AND</p> $[\text{Flow}] \{169-1-6\} \geq ([\text{Ctrl_Setpoint}] \{158-1-6\} - (0.5 * [\text{Ctrl_Warn_Error_Band}] \{158-1-16\}))$

Bit 13: Setpoint Overrange [Active_Warnings_SP_Overrange]

The status indicates the current setpoint has exceeded an upper threshold.

This diagnostic is **disabled** when **[Ctrl Warn SP Hi] {158-1-201} = 0**
(None)

Bit Value	Description
1	$[\text{Ctrl_Setpoint}] \{158-1-6\} > [\text{Ctrl Warn SP Hi}]\{158-1-201\}$ <p style="text-align: center;">FOR</p> <p style="text-align: center;">Time Period > [Ctrl Warn SP Hi On Delay]{158-1-202}</p>
0	$[\text{Ctrl_Setpoint}] \{158-1-6\} < [\text{Ctrl Warn SP Hi}]\{158-1-201\}$ <p style="text-align: center;">FOR</p> <p style="text-align: center;">Time Period > [Ctrl Warn SP Hi Off Delay]{158-1-203}</p>

Bit 14: Setpoint Limited [Active_Warnings_SP_Limited]

The status indicates the [Ctrl_Setpoint] {158-1-6} has been limited by a [Ctrl_SP_Lim] {158-1-204}.

This diagnostic is *disabled* when [Ctrl SP Lim]{158-1-204} = 0 (None)

Bit Value	Description
1	[Ctrl_Setpoint] {158-1-6} > [Ctrl_SP_Lim] {158-1-204} FOR Time Period > [Ctrl Warn SP Lim On Delay]{158-1-205}
0	[Ctrl_Setpoint] {158-1-6} < [Ctrl_SP_Lim] {158-1-204} FOR Time Period > [Ctrl Warn SP Lim Off Delay]{158-1-206}

Bit 15: Zero Recommended

This status indicates that the device should be zeroed. This diagnostic is run when setpoint is changed to 0.0%

This diagnostic is disabled when:

- [Zero Warn Band]{169-1-161} == 0
- Safe State == True
- Valve Override = True (MFCs Only)
- [Ctrl Setpoint]{158-1-6} > 0

Bit Value	Description
1	[Flow]{169-1-6} > [Zero Warn Band]{169-1-161} FOR Time Period > [Zeor Warn On Delay]{169-1-160}
0	[Flow]{169-1-6} <= [Zero Warn Band]{169-1-161}

Bit 16: Overhaul Due [Active_Warnings_Overhaul_Due]

This status indicates that device requires maintenance.

See section Flow Meter Object, Section 6.x for details on Totalizers and Timers.

Bit Value	Description
1	[Overhaul_Due_Hours] {169-1-226} = 0
0	[Overhaul_Due_Hours] {169-1-226} > 0

Bit 17: Calibration Due [Active_Warnings_Cal_Due]

This status indicates the device needs to be calibrated.

See section Flow Meter Object, Section 6.x for details on Totalizers and Timers.

Bit Value	Description
1	[Cal_Due_Hours] {161-1-21} = 0
0	[Cal_Due_Hours] {161-1-21} > 0

Bit 24: High Temperature Warning [Active_Warnings_High_Temp]

The status indicates a high internal device temperature warning condition.

See Diagram in section Typical Status High/Low Processing for typical behavior of this status.

Bit Value	Description
1	[Temperature] {164-1-6} > [High_Temp_Warn_TP] {164-1-17} FOR Time Period > [Temp Warn On Delay]{164-1-19}
0	[Temperature] {164-1-6} < [High_Temp_Warn_TP] {164-1-17} FOR Time Period > [Temp Warn Off Delay]{164-1-20}

Bit 25: Low Temperature Warning [Active_Warnings_Low_Temp]

This status indicates a low internal device temperature status condition.

See Diagram in section Typical Status High/Low Processing for typical behavior of this status.

Bit Value	Description
1	[Temperature] {164-1-6} < [Low_Temp_Warn_TP] {164-1-18} FOR Time Period > [Temp Warn On Delay]{164-1-19}
0	[Temperature] {164-1-6} > [Low_Temp_Warn_TP] {164-1-18} FOR Time Period > [Temp Warn Off Delay]{164-1-20}

Bit 26: Power Supply Warning

The status indicates that the supply voltage is above the high warning trip point or below the low warning trip point

See Diagram in section Typical Status High/Low Processing for typical behavior of this status.

Bit Value	Description
1	<p>[Supply_V] {100-1-190} > [Supply_V_Max_Limit] {100-1-192} OR [Supply_V]{100-1-190} < [Supp V Min Limit]{100-1-191} FOR Time Period > [Supply_V_Settle_Time] {100-1-193}</p>
0	<p>[Supply_V] {100-1-190} < [Supply_V_Max_Limit] {100-1-192} AND [Suppl V][100-1-190] >= [Supply V Min Limit]{100-1-191} FOR Time Period > [Supply_V_Settle_Time] {100-1-193}</p>

Bit 31: CPU Temperature High Warning

This status indicates the the CPU temperature is very high.

Bit Value	Description
1	CPU Temperature > Temp Threshold
0	CPU Temperature <= Temp Threshold

Alarms {184-1-4}

Bit 0: Low Flow Alarm [Active_Alarms_Low_Flow]

The status indicates a low flow alarm condition.

See Diagram in section Typical Status High/Low processing for typical behavior of this status.

This diagnostic is *disabled* when **Safe State** == True

OR

Valve Override == True (MFCs Only)

Bit Value	Description
1	$[\text{Flow}] \{169-1-6\} < [\text{Flow_Alarm_TP_Low}] \{169-1-18\}$ <p style="text-align: center;">FOR</p> <p style="text-align: center;">Time Period > [Flow Alarm On Delay]{169-1-20}</p>
0	$[\text{Flow}] \{169-1-6\} > ([\text{Flow_Alarm_TP_Low}] \{169-1-18\} + [\text{Flow_Alarm_Hyst}] \{169-1-19\})$ <p style="text-align: center;">FOR</p> <p style="text-align: center;">Time Period > [Flow Alarm Off Delay]{169-1-28}</p>

Bit 1: High Flow Alarm [Active_Alarms_High_Flow]

This status indicates a high flow alarm condition.

See Diagram in section Typical Status High/Low Processing for typical behavior of this status.

This diagnostic is *disabled* when **Safe State** == True

OR

Valve Override == True (MFCs Only)

Bit Value	Description
1	$[\text{Flow}] \{169-1-6\} > [\text{Flow_Alarm_TP_High}] \{169-1-17\}$ <p style="text-align: center;">FOR</p> <p style="text-align: center;">Time Period > [Flow Alarm On Delay]{169-1-20}</p>
0	$[\text{Flow}] \{169-1-6\} < ([\text{Flow_Alarm_TP_High}] \{169-1-17\} - [\text{Flow_Alarm_Hyst}] \{169-1-19\})$ <p style="text-align: center;">FOR</p> <p style="text-align: center;">Time Period > [Flow Alarm Off Delay]{169-1-28}</p>

Bit 2: No Flow Alarm [Active_Alarms_No_Flow]

This status indicates a no flow conditions exists.

This diagnostic is *disabled* when *any* of the following conditions exist:

- [Ctrl No Flow Limit]{158-1-160} == 0
- [Ctrl_Setpoint] {158-1-6} = 0
- Valve Override == True
- Safe State == True
- [Valve Position]{150-1-6} < 98%

Bit Value	Description
1	[Flow] {169-1-6} < [Ctrl No Flow Lim]{158-1-160} FOR Time Period > [Ctrl No Flow On Delay]{158-1-161}
0	[Flow] {169-1-6} >= [Ctrl No Flow Lim]{158-1-160}

Bit 3: Choked Flow Alarm [Active_Alarms_Choked_Flow]

This status indicates a choked flow condition exists.

This diagnostic is *disabled* when *any* of the following conditions exist:

- [Ctrl Choked Flow Alarm Limit]{158-1-165} == 0
- [Ctrl_Setpoint] {158-1-6} = 0
- Valve Override == True
- Safe State == True
- [Valve Drive]{150-1-6} < 0.98

Bit Value	Description
1	[Flow] {169-1-6} < ([Ctrl Choked Flow Alarm Limit]{158-1-165} * [Ctrl_Setpoint] {158-1-6}) FOR Time Period > [Ctrl Choked Flow Alarm On Delay]{158-1-166}
0	[Flow] {169-1-6} > ([Ctrl Choked Flow Alarm Limit]{158-1-165} * [Ctrl_Setpoint] {158-1-6}) FOR Time Period > [Ctrl Choked Flow Alarm Off Delay]{158-1-166}

Bit 5: High Temperature Alarm [Active_Alarms_High_Temp]

The status indicates a high internal device temperature alarm condition.
See Diagram in section Typical Status High/Low Processing for typical behavior of this status.

Bit Value	Description
1	$[\text{Temperature}] \{164-1-6\} > [\text{High_Temp_Alarm_TP}] \{164-1-21\}$ FOR Time Period $> [\text{Temp Alarm On Delay}] \{164-1-23\}$
0	$[\text{Temperature}] \{164-1-6\} < [\text{High_Temp_Alarm_TP}] \{164-1-17\}$ FOR Time Period $> [\text{Temp Alarm Off Delay}] \{164-1-24\}$

Bit 6: Low Temperature Alarm [Active_Alarms_Low_Temp]

This status indicates a low internal device temperature status condition.
See Diagram in section Typical Status High/Low Processing for typical behavior of this status.

Bit Value	Description
1	$[\text{Temperature}] \{164-1-6\} < [\text{Low_Temp_Alarm_TP}] \{164-1-22\}$ FOR Time Period $> [\text{Temp Alarm On Delay}] \{164-1-23\}$
0	$[\text{Temperature}] \{164-1-6\} > [\text{Low_Temp_Alarm_TP}] \{164-1-22\}$ FOR Time Period $> [\text{Temp Alarm Off Delay}] \{164-1-24\}$

Bit 7: Valve High Alarm [Active_Alarms_Valve_High]

The status indicates the valve position has exceeded a high position threshold.
See Diagram in section Typical Status High/Low Processing for typical behavior of this status.

Bit Value	Description
1	$[\text{Valve_Position}] \{150-1-6\} > [\text{Valve_Alarm_TP_High}] \{150-1-15\}$
0	$[\text{Valve_Position}] \{150-1-6\} <$ $([\text{Valve_Alarm_TP_High}] \{150-1-15\} + [\text{Valve_Alarm_Hyst}] \{150-1-17\})$

Bit 8: Valve Low Alarm [Active_Alarms_Valve_Low]

The status indicates the valve position has exceeded a low position threshold.
See Diagram in section Typical Status High/Low Processing for typical behavior of this status.

Bit Value	Description
1	$[\text{Valve_Position}] \{150-1-6\} < [\text{Valve_Alarm_TP_Low}] \{150-1-16\}$
0	$[\text{Valve_Position}] \{150-1-6\} >$ $([\text{Valve_Alarm_TP_Low}] \{150-1-16\} + [\text{Valve_Alarm_Hyst}] \{150-1-17\})$

Bit 15: Invalid Process Gas Page Selected [Active_Alarms_Invalid_Cal_Page]

This status indicates that an invalid process gas page ID is being selected through assembly 110. This status will be set but the process gas page will not be changed.

Bit Value	Description
1	This bit is set when an invalid process gas page ID is received by the device
0	The process gas page received by the device is valid

Bit 18: Internal Communication Alarm

This status indicates that the communications between the main board and the communications daughter board may fail imminently.

Bit Value	Description
1	Failure Imminent
0	Internal Communications OK

Bit 23: Using Backup NV Memory [Active_Alarms_NV_Mem]

This status indicates that primary non-volatile memory has failed, and the device is using backup nonvolatile memory.

Bit Value	Description
1	This bit is set when NV Memory write failure has been detected
0	Indicates NV Memory write failure has not occurred

Bit 31: Internal Alarm

This status indicates an unspecified internal Alarm has been raised.

Bit Value	Description
1	Internal Alarm Raised
0	No internal alarms detected

Errors {184-1-3}

Bit 0: Internal Failure

This status indicates that an unspecified error has occurred.

Bit Value	Description
1	Internal failure detected
0	This bit can only be cleared with a reset of the device

Bit 2: Back Streaming Error [Active_Errors_Bk_Stream]

This status indicates that a back stream condition exists.

This diagnostic is *disabled* when *any* of the following conditions exist:

- [Back Stream Flow Limit]{169-1-174} == 0
- Device In Purge

Bit Value	Description
1	[Flow] < [Back Stream Flow Limit]{169-1-174} FOR Time Period > [Back Stream On Delay]{169-1-175}
0	This bit can only be cleared with a reset of the device

Bit 8: Temperature Sensor Fail

This status indicates the temperature sensor has failed.

Bit Value	Description
1	Sensor Failure
0	This bit can only be cleared with a reset of the device

Bit 9: Flow Sensor Fail

This status indicates the flow sensor has failed.

Bit Value	Description
1	Sensor Failure
0	This bit can only be cleared with a reset of the device

Bit 10: Valve Drive Fail

This status indicates the valve drive has failed.

Bit Value	Description
1	Valve Drive Failure
0	This bit can only be cleared with a reset of the device

Bit 18: Internal Communication Error [Active_Errors_Int_Comms]

This bit indicates that the communications between the main board and the communications daughter board has failed.

Bit Value	Description
1	Error Detected
0	This bit can only be cleared with a reset of the device

Bit 23: NV Memory Fail [Active_Errors_NV_Mem_Fail]

This status indicates that both primary and backup non-volatile memories have had write failures detected.

Bit Value	Description
1	Non-volatile memory fail detected
0	This bit can only be cleared with a reset of the device

Typical Status High/Low Processing

The following diagrams represent typical Status Low and Status High processing of signals. Several status definitions reference these diagrams.

Status Low Processing

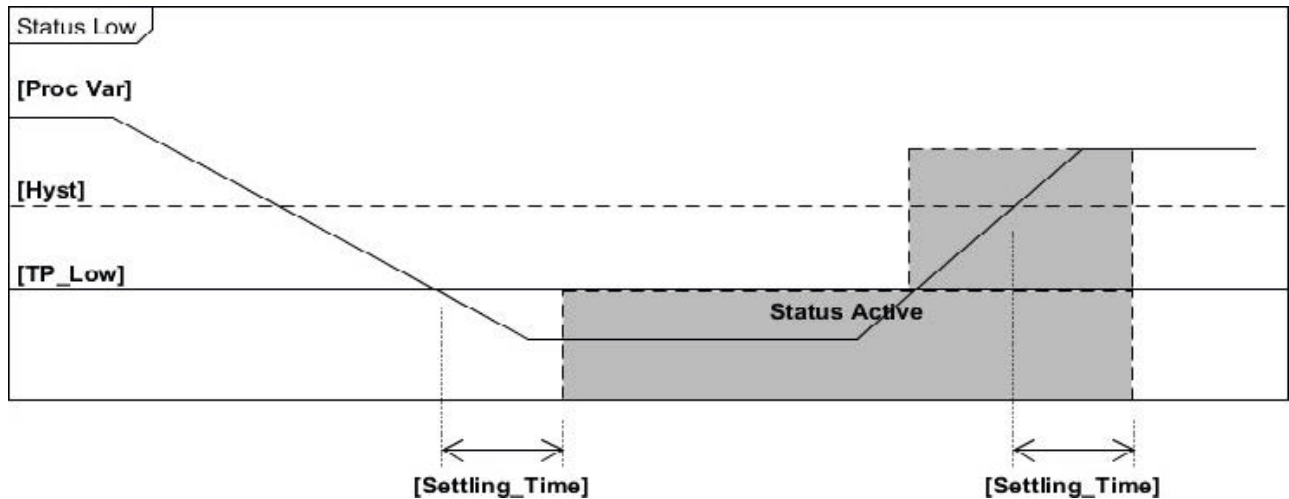

Status High Processing

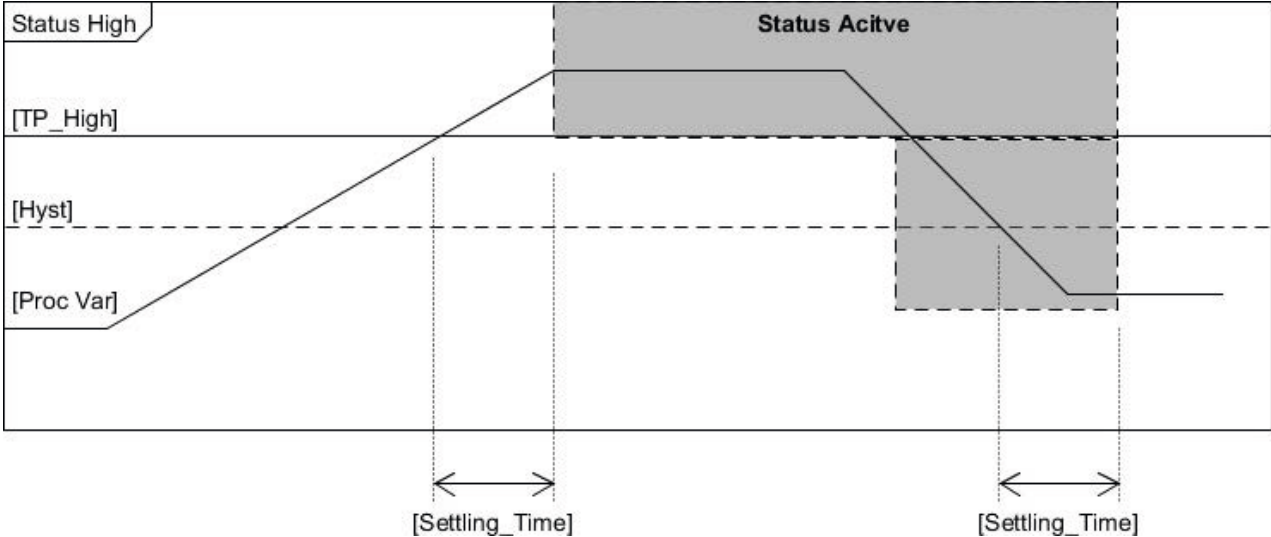

Problem	Possible Causes
<p>Scanner is actively scanning the network, but the NET LED is flashing green and MOD LED is solid green</p>	<p>The TCP/IP address for the device is not programmed into the scanner or does not match a device address already programmed in the scanner</p> <p>The TCP/IP address for the device is programmed into the scanner. Scanner cannot connect to the device because of one of the following:</p> <ol style="list-style-type: none"> 1) The Produce/Consume/Config assembly data sizes are mismatched. The sizes programmed into the master/scanner do not match the connection configuration. See section 'Class 1 Connections' or reference the EDS file for the correct assembly sizes 2) The Input/Output/Config assembly IDs for the connection configuration are mismatched. See section 'Class 1 Connections' or reference the EDS file for the correct assembly ID's 3) The scanner is programmed to send data to the configuration assembly when the connection is established, however one or more of the data fields in the configuration data have invalid values.
<p>Scanner is actively scanning the network and NET LED goes from solid green to flashing red and the MOD LED is solid green.</p>	<p>The exclusive owner connection to the device has timed out and has not been re-established.</p>
<p>When power is applied to the device the NET LED goes solid red and the MOD LED is solid green.</p>	<p>The IP address configured in the device conflicts with another device on the network.</p>
<p>When power is applied to the device the NET LED remains off and the MOD LED is solid green.</p>	<p>An TCP/IP Address has not been assigned to the device.</p>
<p>When power is applied to the device, the MOD LED switches from flashing Red/Green to solid Red.</p>	<p>Cycle power to the device. If problem persists, contact Brooks Instrument Technical Services.</p>
<p>The device never comes out of Self-Test (MOD LED continually flashes red/green).</p>	<p>Cycle power to the device. If problem persists, contact Brooks Instrument Technical Services.</p>
<p>A setpoint value is being sent to the device, but the MFC fails control flow (i.e. no actuator movement, low or no flow indication)</p>	<p>Check to make sure that the scanner is not setting the Run/Idle bit to Idle. This can occur if the scanner is put into a special program mode or the device in question has been placed into an "Idle" or "Inhibit" mode.</p>

Appendix A - Ethernet/IP Connections

AMF EIP MFC/MFM support Class 1 Messaging connections and Class 3 Messaging connections. Class 1 connections are used to pass a grouping of data continuously between the Master scanner and the target device at fast update rates. The grouping of data is defined by Assembly objects (see section 'Data Assemblies'). The Assemblies are defined to be used with certain connection types. The following sections discuss the following connection types and how they might be utilized on an Ethernet/IP network.

Exclusive Owner Connection

The terms Originator(O) and Target(T) are sometimes used to refer to the two devices respectively. With the Exclusive Owner connection, ownership of the device is established, and data is generally (not always) exchanged in both directions. The Owner-to-Target (O or T) connection is usually point-to-point (unicast). The Target-to-Owner (T or O) connection can be either unicast or multicast. Unicast restricts the data exchange between the two devices only. A multicast connection allows other devices to subscribe to the data being exchanged in the T or O connection using Listen Only or Input Only connections if the target device supports this type of connection for the data assembly.

Input Only Connection

The Input Only connection establishes and exchange of data, primarily from the Target to the Owner (T or O). The Originator of this connection can be any device on the network including the Owner device. The T or O data is 0 length (NULL) and is used as a 'heartbeat' to keep the connection active. The Target-to-Owner (T or O) connection can be either unicast or multicast. Unicast restricts the data exchange between the two devices only. A multicast connection allows other devices to subscribe to the data being exchanged in the T or O connection using Listen Only or Input Only connections if the target device supports this type of connection for the data assembly.

Appendix B - Data Type Definitions

The following table list ODVA data types used throughout this manual and in the ODVA specification. The column C/C++ Encoding is given as a comparative common example reference.

Table 9-1 Data Types

Data Type	Size (bytes)	Description	Range	C/C++ Keyword
BOOL	1	A true/false represented as 0 = false and 1 = true	0 and 1	bool
SINT	1	An 8-bit signed integer value	-128 to 127	char
USINT	1	An 8-bit unsigned integer value	0 to 255	unsigned char
INT	2	A 16-bit signed integer value	-32768 to 32767	short int
UINT	2	A 16-bit unsigned integer value	0 to 65535	unsigned short int
DINT	4	A 32-bit signed integer value	-2147483648 to 2147483647	int
UDINT	4	A 32-bit unsigned integer	0 to 4294967296	unsigned int
REAL	4	An IEEE single precision floating point number	3.4E38 to -3.4E38	float
DREAL	8	An IEEE double precision floating point number		Long
ENGUNIT	2	An enumerated value representing an engineering unit of measure	4096 - 65535	N/A
BYTE	1	An 8-bit Bitfield	N/A	N/A
SHORT STRING	Up to 128 bytes	A character array where the first byte is the number of characters in the array, and the subsequent bytes contain the ASCII characters. This is not a NULL terminated string.	N/A	N/A

Appendix C – Data Units

Table 9-2: Volumetric Flow Units Table

Description	Symbol	Units Code	
		Decimal	Hex
Percent	%	4103	0x1007
Cubic Centimeters per Hour	cc/hr	5162	0x142A
Cubic Centimeters per Minute	cc/min	5163	0x142B
Cubic Centimeters per Second	cc/sec	5164	0x142C
Liters per Hour	L/hr	5140	0x1414
Liters per Minute	L/min	5139	0x1413
Liters per Second	L/sec	5126	0x1406
Milliliters per Hour	mL/hr	5138	0x1412
Milliliters per Minute	mL/min	5137	0x1411
Milliliters per Second	mL/sec	5127	0x1407
Standard Cubic Centimeters per Minute	sccm	5120	0x1400
Standard Liters per Minute	SLPM	5121	0x1401

Table 9-3: Actuator Units

Description	Symbol	Units Code	
		Decimal	Hex
Percent	%	4103	0x1007

Table 9-4: Temperature Units

Description	Symbol	Units Code	
		Decimal	Hex
deg C	°C	4608	0x1200
deg F	°F	4609	0x1201

Table 9-5: Volume Units Table (Used by Totalizers)

Description	Symbol	Units Code	
		Decimal	Hex
Liter	L	11778	0x2E02
Milliliters	mL	11779	0x2E03

Appendix D - Service Summary Details

Table 9-6: Get Attribute Single Service Parameters

Parameter Name	Data Type	Required	Description	Default
Attribute ID	USINT	Y	The attribute ID of the attribute to be read	None

Table 9-7: Success Response Data

Return Value	Data Type	Description
Attribute Value	The Data Type of the Attribute being read	

Table 9-8: Set Attribute Single Service Parameters

Parameter Name	Data Type	Required	Description	Default
Attribute ID	USINT	Y	The attribute ID of the attribute to be read	None
Attribute Value	(Equivalent to the data type of the Attribute)	Y	The value to which the attribute will be set	None

Table 9-9: Success Response Data

Return Value	Data Type	Description
No Success Response Data		

This section is intended as a brief overview of Ethernet/IP™ terminology used throughout this manual.

Assembly

An Assembly is a Class that defines a collection of EPATH(s). This collection allows multiple attributes to be accessed all at once. Each instance of an Assembly defines a unique set of EPATH(s).

Attribute

A Parameter or Data Item that may be read or written and is used for the purpose of configuration or is used to obtain information.

Example:

The attribute Data Units defines the engineering units flow will be reported in. The attribute Value indicates the current flow through the device. Attributes can be read/write or read only.

Class

A logical collection of related Attributes that define a particular function and/or behavior.

Example:

The Flow Meter contains information about configuring a meter, the current status of the meter, and/or the current value of what is being flowed.

Connection

A connection is a logical link between two devices by which messages are transferred. A device can have 1 or more simultaneous Connections.

Device Profile

A specification that defines a set of CIP objects that uniquely represents a particular device of that type or class. The device profile can further define attributes, services, assemblies, etc. that a device must support to be considered part of that type or class of device. These profiles are found in the ODVA specification, Vol. 1. The AMF Series MFC/MFM conforms to the Generic device profile.

EDS

The Electronic Data Sheet (EDS) is a specially formatted text description for a device that describes the connection characteristics and configurable parameters that are accessible via the Ethernet/IP™ network. EDS files can be read by configuration software used to configure Ethernet/IP™ networks.

EPATH

An EPATH is a unique identifier (sometimes referred to as a pointer) comprised of a Class ID, an Instance ID, and an Attribute ID. Some Classes have EPATH attributes that point to a particular data item. An example of this would be the Connection Class that contains two attributes, Produce Path and Consume Path. These attributes define where incoming data is sent to, and outgoing data comes from.

Expected Packet Rate (EPR)

The EPR is an attribute in the Connection Class that defines the maximum amount of time (in msec) messages should be received by the Connection (implementation of this value is dependent upon the Connection type, Class 1 or Class 3, but the behavior is the same in all Connection types). If the time between received messages for that connection exceeds the EPR, the Connection times out. This may result in the Connection being released by the device.

Class 3 Connection

A Class 3 Connection dictates a request and response exchange between two devices. The device sending the request must get a response from the device receiving the request message. Embedded in the Message is information about the Class, Instance, Attribute, Service, and any service data needed to process the message. As a result, processing of Messages generally takes longer than Class 1 messaging. This is why Class 3 Connections are typically used for commissioning/configuration.

Class 1 Connection

Class 1 Connections are used for the exchange of data only. How a device processes the data and/or responds with data via an Connection is defined within the Connection(s) configurations.

Instance

An instance of a Class is a particular invocation of a Class (sometimes referred to as an Object). An Instance of a Class is unique in describing the behavior for a particular kind of object. Each instance of the class contains the same set of attributes defined by the class. The uniqueness of the instance is defined by the attribute values.

Safe State (Safe Mode)

An operational mode or state that is considered “safe” whereby the normal controller process is shut down and mechanical and sensing mechanisms are placed in a safe condition.

Service

A service is a pre-defined action that a Class provides. The most commonly used services are used to configure the device such as Get Attribute (0x0E) or Set Attribute (0x10). Other types of services may directly affect the behavior of a Class (or Object) such as Reset (0x5), Stop (0x6), or Start (0x7). There are many more services not listed here and each Class specifies which Services it supports.

LIMITED WARRANTY

Visit www.BrooksInstrument.com for the terms and conditions of our limited warranty.

BROOKS SERVICE AND SUPPORT

Brooks is committed to assuring all our customers receive the ideal flow solution for their application, along with outstanding service and support to back it up. We operate first class repair facilities located around the world to provide rapid response and support. Each location utilizes primary standard calibration equipment to ensure accuracy and reliability for repairs and recalibration and is certified by our local Weights and Measures Authorities and traceable to the relevant International Standards.

Visit www.BrooksInstrument.com to locate the service location nearest to you.

START-UP SERVICE AND IN-SITU CALIBRATION

Brooks Instrument can provide start-up service prior to operation when required.

For some process applications, where ISO-9001 Quality Certification is important, it is mandatory to verify and/or (re)calibrate the products periodically. In many cases this service can be provided under in-situ conditions, and the results will be traceable to the relevant international quality standards.

SEMINARS AND TRAINING

Brooks Instrument can provide seminars and dedicated training to engineers, end users and maintenance persons.

Please contact your nearest sales representative for more details.

Due to Brooks Instrument's commitment to continuous improvement of our products, all specifications are subject to change without notice.

TRADEMARKS

Brooks is a trademark of Brooks Instrument, LLC
All other trademarks are the property of their respective owners.



EtherNetIP-Manual-AMF-Series-EN/2026-06

Global Headquarters

Brooks Instrument
407 West Vine Street
Hatfield, PA
19440-0903 USA

Toll-Free (USA): 888-554-FLOW
T: 215-362-3500

BrooksAM@BrooksInstrument.com

A list of all Brooks Instrument locations and contact details can be found at www.BrooksInstrument.com

© Copyright 2026 Brooks Instrument, LLC All rights reserved. Printed in U.S.A.

BROOKS[®]
INSTRUMENT
Beyond Measure