

## Installation and Operation Manual

X-TMF-5853-63-MFC-eng

PN 541-C-022-AAG

November, 2008

# Brooks® Mass Flow Meter Model 5863 Mass Flow Controller Model 5853



## WARNING

This publication must be read in its entirety before performing any operation. Failure to understand and follow these instructions could result in serious personal injury and/or damage to the equipment.

Should this equipment require repair or adjustment, contact the nearest Rosemount Sales Office. It is important that servicing be performed only by trained and qualified personnel. If this equipment is not properly serviced, serious personal injury and/or damage to the equipment could result.

Dear Customer,

The Brooks Mass Flow Meter/Controller you have just received is of the highest quality available, offering superior performance to the user. This instrument provides the finest degree of accuracy, repeatability and widest operating parameters available for extremely reliable gas measurement and control of mass flow rate.

In view of the wide variety of applications for mass flow meters and controllers, we have expressly designed this instrument to provide user selectable functions in a single instrument to meet ever-changing process conditions. Additionally, this 'State of the Art' design has been packaged and materials selected to permit application to a variety of often corrosive and hostile conditions.

To realize the full potential of the inherent design flexibility and easy of maintenance, we request you to review this manual in its entirety.

Should you need additional information concerning the 5853 Mass Flow Controller or 5863 Mass Flow Meter, please feel free to contact your local Rosemount Sales Office. We are pleased to have this opportunity of servicing you for your gas measurement and control needs and hope that we will be able to help you further in the future.

Sincerely,  
Brooks Instrument B.V.

## CAUTION

**This instrument contains electronic components that are susceptible to damage by static electricity. Proper handling procedures must be observed during the removal, installation or other handling of internal circuit boards or devices.**

### Handling Procedure:

1. Power unit must be removed.
2. Personnel must be grounded, via a wrist strap or other

#### Handling Procedure:

1. Power unit must be removed.
2. Personnel must be grounded, via a wrist strap or other safe, suitable means, before any printed circuit card or other internal device is installed, removed or adjusted.
3. Printed circuit cards must be transported in a conductive bag or other conductive container. Boards must not be removed from protective enclosure until the immediate time of installation. Removed boards must be placed immediately in protective container for transport, storage or return to factory.

### Comments:

This instrument is not unique in its content of ESD (electrostatic discharge) sensitive components. Most modern electronics designs contain components that utilize metal oxide technology (NMOS, CMOS, etc.). Experience has proven that even small amounts of static electricity can damage or destroy these devices. Damaged components, even though they appear to function properly, exhibit early failure.

# TABLE OF CONTENTS

|   | Paragraph<br>number | Page<br>number |
|---|---------------------|----------------|
| <b>SECTION 1 INTRODUCTION</b>   |                     |                |
| Purpose.....  | 1-1                 | 5              |
| Description.....  | 1-2                 | 5              |
| Specifications.....   | 1-3                 | 6              |
| <b>SECTION 2 INSTALLATION</b>   |                     |                |
| Receipt of Equipment.....   | 2-1                 | 7              |
| Recommended Storage Practice.....                                       | 2-2                 | 7              |
| Gas Connections.....  | 2-3                 | 7              |
| Installation.....   | 2-4                 | 8              |
| In-Line Filter.....   | 2-5                 | 9              |
| Electrical Interfacing Models 5853E/5863E.....                          | 2-6                 | 9              |
| Electrical Interfacing Models 5853i/5863i.....                          | 2-7                 | 10             |
| <b>SECTION 3 OPERATING INSTRUCTIONS</b>                                 |                     |                |
| Theory of Operation.....  | 3-1                 | 13             |
| Operating Procedure.....  | 3-2                 | 14             |
| Zero Adjustment.....  | 3-3                 | 14             |
| Response.....   | 3-4                 | 14             |
| <b>SECTION 4 MAINTENANCE</b>  |                     |                |
| General.....  | 4-1                 | 16             |
| Troubleshooting.....  | 4-2                 | 17             |
| Sensor Tube.....  | 4-3                 | 18             |
| Disassembly and Assembly.....   | 4-4                 | 20             |
| <br><b>LIST OF ILLUSTRATIONS</b>  |                     |                |
|   | Figure              | Page<br>number |
| Setpoint Steps, Soft Start Disabled.....                                | 1-1                 | 5              |
| 0-100% Setpoint Steps, Soft Start Enabled.....                          | 1-2                 | 6              |
| Model 5863 Dimensions.....  | 2-1                 | 7              |
| Model 5863 Dimensions.....  | 2-2                 | 7              |
| Model 5853 Dimensions.....  | 2-3                 | 8              |
| Model 5853 Dimensions.....  | 2-4                 | 8              |
| Type 'D'-Connector Pin Arrangement Models 5853E and 5863E.....          | 2-5                 | 8              |
| Card Edge Connector Hook-up Diagram Models 5853E/5863E.....             | 2-6                 | 9              |
| Type 'D'-Connector Pin Arrangement Models 5853i/5863i.....              | 2-7                 | 11             |
| Maximum Allowable Loop Resistance.....                                  | 2-8                 | 11             |
| Common Electrical Hook-Ups.....   | 2-9                 | 11             |
| Flow Control System Block Diagram.....                                  | 3-1                 | 13             |
| Adjustment Potentiometer Location.....                                  | 3-2                 | 14             |
| Fast Response Adjustment.....   | 3-3                 | 15             |
| PC Board Jumper Location and Function Models 5853E/5863E.....           | 3-4                 | 15             |
| PC Board Jumper Location and Function.....                              | 3-5                 | 16             |
| Card Edge PC Board Jumper Location and Function Models 5853i/5863i..... | 3-6                 | 16             |
| Torque Sequence for Valve Retainer Plate.....                           | 4-1                 | 19             |
| Valve Adjusting Spacer Locations.....                                   | 4-2                 | 20             |
| Voltmeter Connections for Valve Adjustment.....                         | 4-3                 | 22             |
| Model Parts Drawing.....  | 5-1                 | 24             |

## TABLE OF CONTENTS (Continued)

| <b>LIST OF TABLES</b>                                | <b>Table<br/>number</b> | <b>Page<br/>number</b> |
|--|-------------------------|------------------------|
| Bench Troubleshooting Models 5853 and 5863 .....     | 4-1                     | 18                     |
| Sensor Troubleshooting.....                          | 4-3                     | 19                     |
| Model Series Replacment Parts List and Drawing ..... | 5-1                     | 25                     |

## Section 1 INTRODUCTION

### 1-1 PURPOSE

The Brooks Model 5853 Flow Controller is a mass flow measurement device designed for accurately measuring and rapidly controlling flows of gases. The Model 5863 Mass Flow Meter accurately measures gasflows. This instruction manual is intended to provide the user with all the information necessary to install, operate and maintain the Brooks Mass Flow Controller or Mass Flow Meter. This manual is organized into five sections:

- Section 1 - Introduction
- Section 2 - Installation
- Section 3 - Operation
- Section 4 - Maintenance
- Section 5 - Replacement Parts

It is recommended that this manual be read in its entirety before attempting to operate or repair the models 5853 or 5863.

### 1-2 DESCRIPTION

The Brooks Model 5863 Mass Flowmeter accurately measures gas flows. The heart of the system is the mass flow sensor which produces an electrical output signal linear with flow rate, used for indicating, recording, and/or control purposes.

Model 5853 Mass Flow Controller is used widely in various industries under rigorous conditions where manual, electronic or computer controlled gas handling occurs. Model 5853 consists of three basic

units: a flowsensor, a control valve and an integral electronic control system. This combination produces a stable gas flow, which eliminates the need to continuously monitor and re-adjust gas pressures.

Standard features include:

- Fast Response Control permits rapid gas settling times with minimal over/undershoot. Refer to figure 1-1.
- Soft Start provides a flow ramping function which slows down the introduction of process gas for those processes which cannot tolerate rapid flow transition. Refer to section 2-7 and figure 1-2.
- Valve Override permits the user to fully open and close the control valve independent of the command setting. Refer to section 2-6.
- Low Command Valve Inhibit (Auto Shutoff) prevents the valve from opening whenever the setpoint is less than 2% of full scale.
- Removable Cleanable Sensor permits the user to clean or replace the sensor. Refer to section 4-4.
- Setpoint (command) permits the user to program the Mass Flow Controller with an external 0-5 Vdc command voltage or 4-20 mA dc signal. Refer to section: 2-6.
- Output Limiting prevents possible damage to delicate data acquisition devices by limiting the output to -0.7 Vdc to +6.8 Vdc on the voltage signal output and 0 to 26 mA on the current output.
- Integral inlet filter, provides flow straightening, reducing the effect of changes in upstream piping. It also, protects measuring element from occasional debris in flow stream.

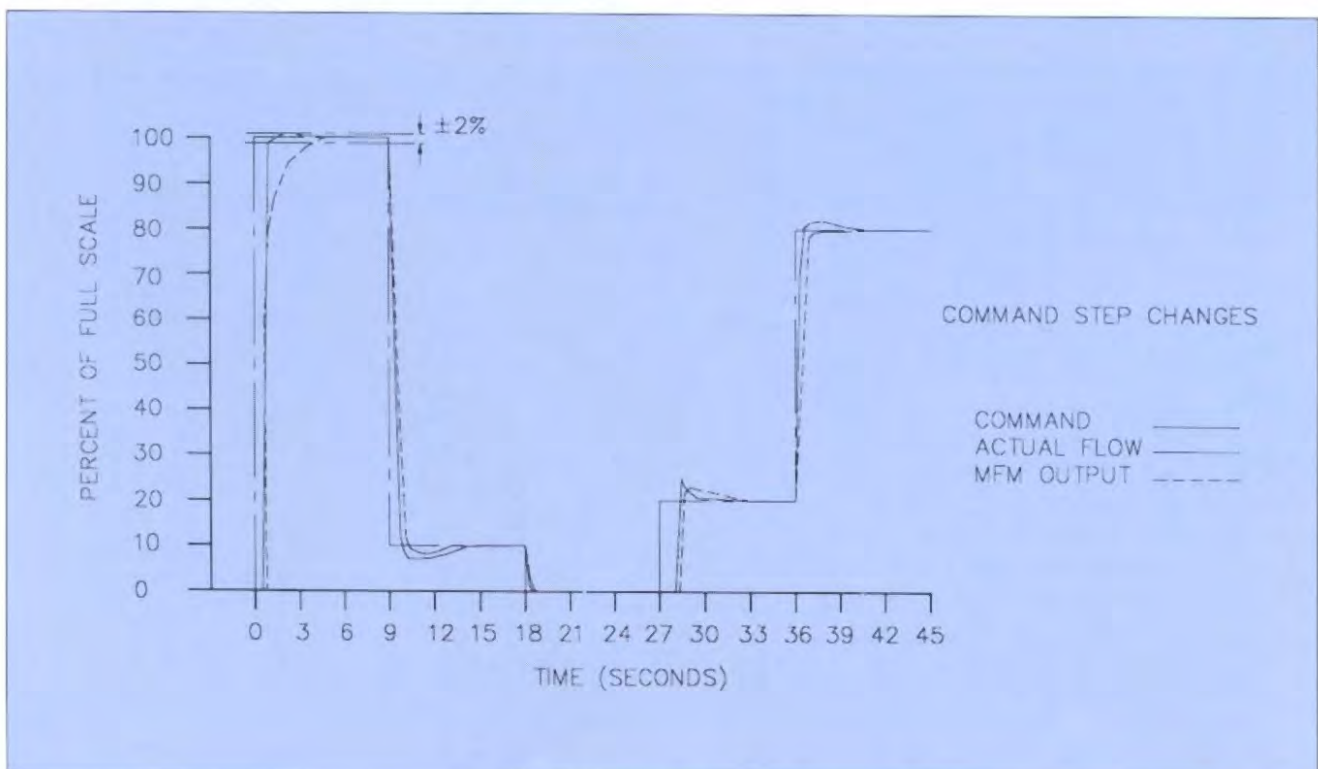

Figure 1-1 Setpoint Steps, Soft Start Disabled

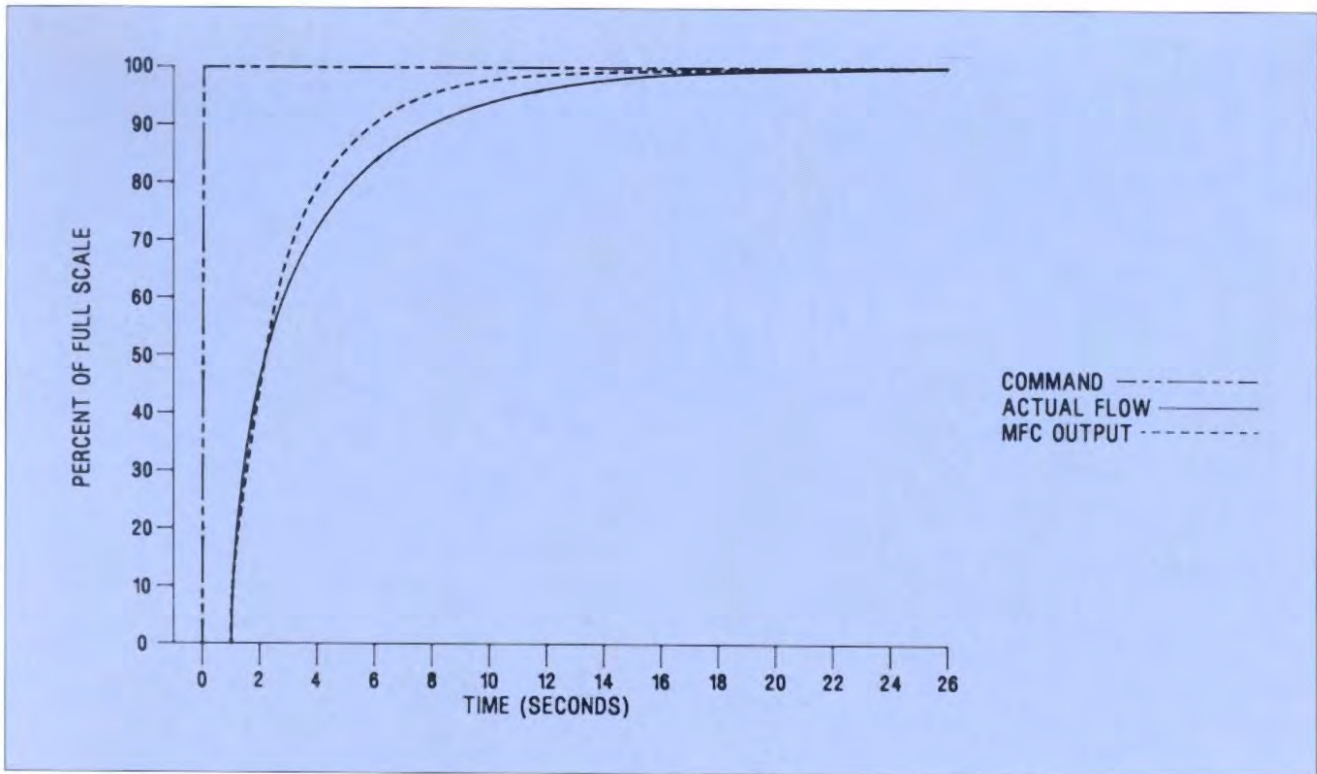

Figure 1-2 0-100% Setpoint Steps Soft Start Enabled

### 1-3 SPECIFICATIONS

**CAUTION:** Do not operate this instrument in excess of the specifications.

#### Performance

|                                |  |
|--------------------------------|--|
| <i>Accuracy</i>                | $\pm 1\%$ full scale including linearity measured at calibrated conditions.  |
| <i>Repeatability</i>           | 0.25% of rate  |
| <i>Rangeability</i>            | 50 to 1.   |
| <i>Flow ranges</i>             | Any full scale range from 100 $I_n$ /min to 1000 $I_n$ /min. Nitrogen equivalent.  |
| <i>Temperature sensitivity</i> | Zero :less than $\pm 0.075\%$ full scale/ $^{\circ}\text{C}$<br>Span:less than $\pm 1.0\%$ full scale shift from original calibration over 10-50 $^{\circ}\text{C}$ range. |

#### Ratings

|                                |  |
|--------------------------------|--|
| <i>Max. operating pressure</i> | 100 bar.   |
| <i>Differential pressure</i>   | <ul style="list-style-type: none"> <li>● <b>Model 5853</b><br/>0.8 bar to 20 bar</li> <li>● <b>Model 5863</b><br/>50 mbar at max full scale</li> </ul> |
| <i>Temperature</i>             | Ambient/gas 0-65 $^{\circ}\text{C}$ .  |
| <i>Leak integrity</i>          | Outboard: $1 \times 10^{-9}$ mbar.l/s Helium   |

### Electrical Specifications

#### MASS FLOW CONTROLLERS

| MODELS | POWER SUPPLY REQUIREMENTS                               | SETPOINT INPUT   | OUTPUT SIGNALS  |
|--------|---|--|---|
| 5853E  | +15 Vdc, 35 mA<br>and<br>-15 Vdc, 180 mA                | 0-5 Vdc<br>2000 Ohm<br>input resist.   | 0-5 Vdc<br>min load<br>2000 Ohm   |
| 5853i  | +15 to +28 Vdc,<br>280 mA @ +15 Vdc<br>370 mA @ +28 Vdc | 0-5 Vdc<br>2000 Ohm<br>input resist.<br>or 4-20 mA<br>(75 Ohm input<br>resistance) | 0-5 Vdc min<br>load 2000 Ohm<br>and<br>0(4)-20 mA with<br>500 Ohm max.<br>loop resistance |

#### MASS FLOW METERS

| MODEL | POWER SUPPLY               | OUTPUT SIGNALS  |
|-------|----------------------------|---|
| 5863E | $\pm 15\text{Vdc}$ @ 25 mA | 0-5 Vdc into 2000 Ohm<br>(or greater) load  |
| 5863i | +15 to +28 Vdc<br>@ 90 mA  | 0-5 Vdc into 2000 Ohm<br>(or greater) load and 0(4)-20 mA<br>with 500 Ohm maximum loop<br>resistance. |

NOTE: Tolerance to the above power requirements:  $\pm 5\%$

|                                  |   |
|----------------------------------|---|
| <i>Materials of construction</i> | Wetted parts stainless steel with Viton <sup>®</sup> , PTFE/-Buna-N <sup>®</sup> , PTFE/Kalrez <sup>®</sup> or PTFE/EPDM.   |
| <i>Mechanical connections</i>    | <ul style="list-style-type: none"> <li>● 1/2", 1", 1 1/2" NPT(F)</li> <li>● 1/2" - 3/4" or 1" Tube compression</li> <li>● 1/2" VCR, 1/2" or 3/4" VCO.</li> </ul> Option: DIN- or ANSI type flanges. |
| <i>Electrical connections</i>    | <ul style="list-style-type: none"> <li>● 15-pins D-type connector (goldplated contacts) with 3 m, 6 m or 12 m cable</li> <li>● Card Edge connector with 1,5 m cable.</li> </ul>                     |

## Section 2 INSTALLATION

### 2-1 RECEIPT OF EQUIPMENT

When the equipment is received, the outside packing case should be checked for damage incurred during shipment. If the packing case is damaged, the local carrier should be notified at once regarding his liability. A report should be submitted to the Product Service Department of Brooks Instrument B.V. Remove the envelope containing the packing list. Carefully remove the equipment from the packing case. Make sure spare parts are not discarded with the packing material. Inspect for damaged or missing parts.

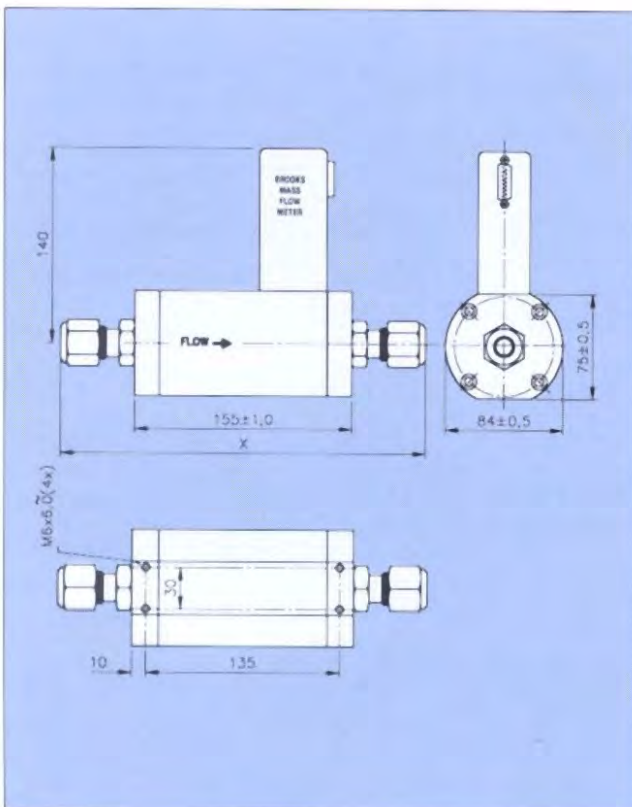

Figure 2-1  
Dim. drawing Model 5863

### 2-2 RECOMMENDED STORAGE PRACTICE

If intermediate or long-term storage is required for equipment, as supplied by Brooks Instrument B.V., it is recommended that said equipment be stored in accordance with the following:

- a. Within the original shipping container.
- b. Store in a sheltered area, with the following conditions:
  1. Ambient temperature 21 °C nominal, 32 °C maximum/7 °C minimum.
  2. Relative humidity 45% nominal, 60% maximum/25% minimum.
- c. Upon removal from storage, a visual inspection should be conducted to verify the condition of the equipment is 'as received'. If the equipment has been in storage for an excess of ten months, or in conditions in excess of the recommended, all pressure boundary seals should be replaced, the device should be subjected to a pneumatic pressure test in accordance with applicable vessel codes.

### 2-3 GAS CONNECTIONS

Standard inlet and outlet connections supplied on Models 5853 and 5863 are 1/2", 3/4" and 1" NPT(F), tube compression fittings, VCR, VCO, DIN or ANSI Flanges. Prior to installation, make certain all piping is clean and free of obstructions. Install the piping in such a manner that permits easy access to the instrument if it needs to be removed for cleaning or test bench troubleshooting.

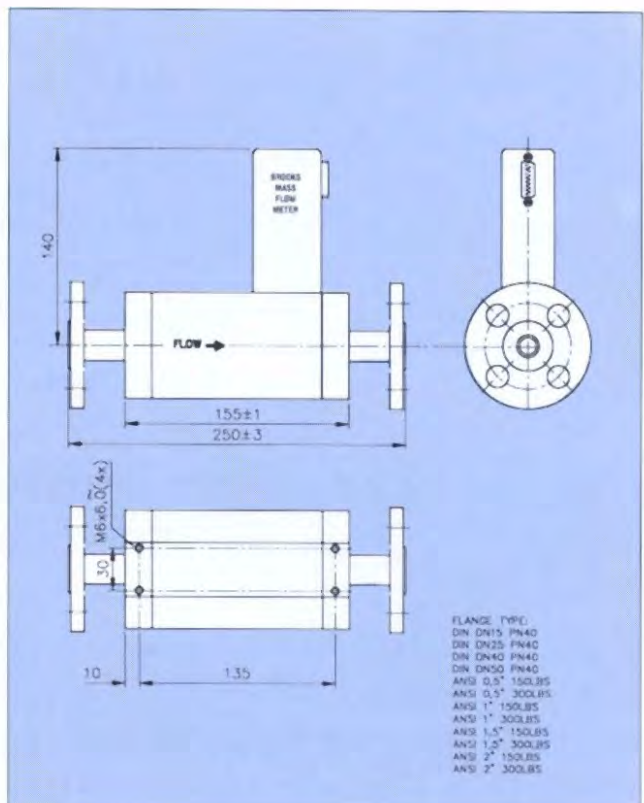

Figure 2-2  
Dim. drawing Model 5863 flanged connection

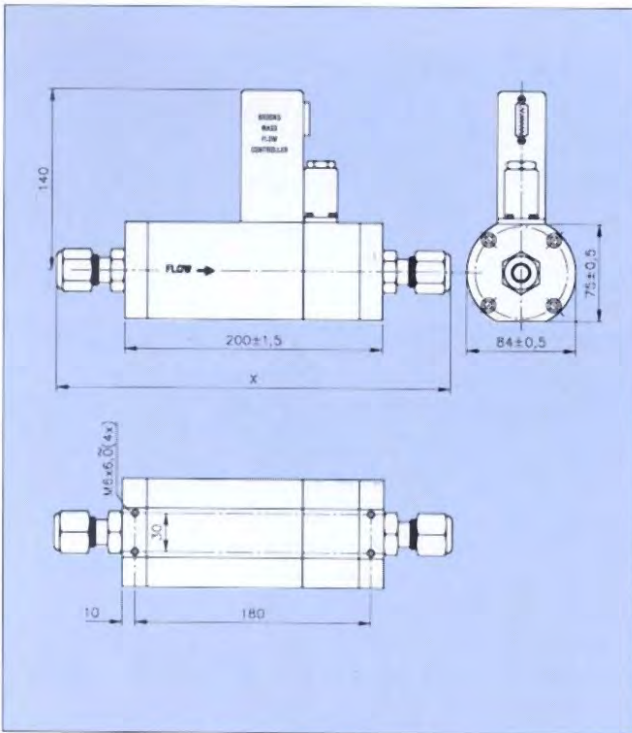

Figure 2-3  
Dim. drawing Model 5853

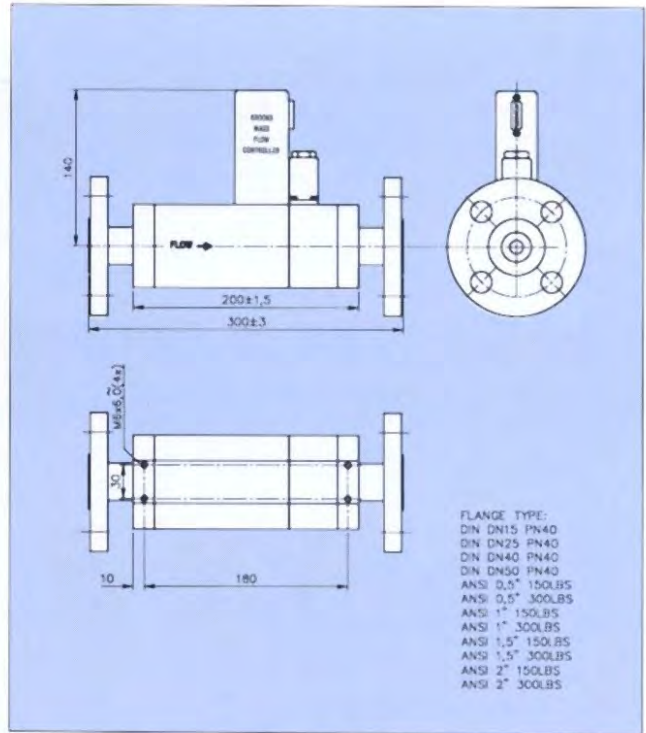

Figure 2-4  
Dim. drawing Model 5853 flanged connection

FLANGE TYPE:  
DIN DN15 PN40  
DIN DN25 PN40  
DIN DN40 PN40  
DIN DN50 PN40  
ANSI 0.5" 150LBS  
ANSI 0.5" 300LBS  
ANSI 1" 150LBS  
ANSI 1" 300LBS  
ANSI 1.5" 150LBS  
ANSI 1.5" 300LBS  
ANSI 2" 150LBS  
ANSI 2" 300LBS

| CONNECTIONS     | BUILD-IN DIMENSIONS (mm) 'X' |            |
|-----------------|------------------------------|------------|
|                 | MODEL 5853                   | MODEL 5863 |
| 1/2" TB. Compr. | 268                          | 223        |
| 3/4" TB. Compr. | 268                          | 223        |
| 1" TB. Compr.   | 277                          | 232        |
| 1/2" VCO        | 258                          | 213        |
| 3/4" VCO        | 258                          | 213        |
| 1/2" VCR        | 257                          | 211        |

## 2-4 INSTALLATION

(Refer to figures 2-1 through 2-4)

**CAUTION:** When installing the Mass Flow Sensor or Controller, care should be taken that no foreign materials enter the inlet or outlet of the instrument. Do not remove the protective end caps until time of installation.

Recommended installation procedures:

- The models 5853 and 5863 should be located in a clean dry atmosphere relatively free from shock and vibration
- Leave sufficient room for access to the electrical components
- Install in such a manner that permits easy removal if the instrument requires cleaning

| PIN OUT - TOP VIEW | Pin. No. | Function  | Color code                      |
|--------------------|----------|---|---------------------------------|
|                    |          | 1   | Cmd. Common (Command Pot 'CCW') |
| 2                  |          | 0-5 Volt Signal Output                                | White                           |
| 3                  |          | Supply Common or External Valve Return (See Note 3)** | Grey/Pink                       |
| 4                  |          | Valve Off   | Red/Blue                        |
| 5                  |          | + 15 Vdc Supply                                       | Red                             |
| 6                  |          | -15 Vdc Supply  | Blue                            |
| 7                  |          | Valve Test Point/Purge function for N.C. valve only   | Violet                          |
| 8                  |          | Cmd. Input or Cmd. Pot 'S'                            | Grey                            |
| 9                  |          | Supply Voltage Common                                 | Black                           |
| 10                 |          | 0-5 Volt Signal Common                                | Pink                            |
| 11                 |          | + 5 Volt Reference Output (Command Pot 'CW')          | Yellow                          |
| 12                 |          | Valve Override  | Green                           |
| 13                 |          | Not Used  | White/Green                     |
| 14                 |          | Chassis Ground  | Shield                          |
| 15                 |          | Remote Transducer Input***                            | Brown/Green                     |

\*\* Jumper Selectable      \*\*\* Factory Adjustable

**Note:**

- Cable shield tied to chassis ground in meter connection. Make no connection on customer end.
- All power leads must be connected to power supply.
- To use pin 3 for external valve return, jumper J1 must be moved to the B-D position and pin 3 must be grounded at the customers system.
- Pin 9 is normally used for external valve return and can be used for cables up to 10 feet in length.

Figure 2-5 "D" Type Connector Pin Arrangement Models 5853E and 5863E



**CAUTION:** When used with a reactive (sometimes toxic) gas, contamination or corrosion may occur as a result of plumbing leaks or improper purging. Plumbing should be checked carefully for leaks and the Mass Flowmeter/Controller purged with dry Nitrogen before use.

- d. The Model 5853 Mass Flow Controller and Model 5863 Mass Flow Meter can be installed in any position. However, mounting orientations other than the original factory calibration (see product data sheet) result in a  $\pm 0.5\%$  maximum full scale shift after re-zeroing.

**Note:**

The control valve in model 5853 provides precision control and is not designed for positive shut off. If positive shut off is required, it is recommended that a separate shut-off valve be installed in-line.

**CAUTION:** Since Model 5853 control valve is not a positive shut-off, a separate solenoid valve may have been installed for that purpose. It should be noted that a small amount of gas may be trapped between the downstream side of the mass flow controller and the solenoid resulting in a surge upon actuation of the controller. This surge can be reduced in magnitude by locating the controller and solenoid valve close together or by moving the solenoid valve upstream of the controller.

**2-5 IN-LINE FILTER**

An in-line filter of 100 microns standard has been installed upstream from the meter or controller to prevent the possibility of any foreign material entering the flow sensor or control valve. The filtering element should be periodically replaced or ultrasonically cleaned.

**2-6 ELECTRICAL INTERFACING  
MODELS 5853E/5863E**

To ensure proper operation, the 5853E/5863E must be connected per figures 2-5 and 2-6 and configured according to section 2-6.

At a minimum, the following connections must be made for new installations:

- Chassis Ground
- 0-5 Volt Signal Common
- 0-5 Volt Signal Output
- + 15 Vdc Supply
- 15 Vdc Supply
- Command Input
- Command Common
- Supply Voltage Common
- Valve Return (Refer to Figures 3-4 and 3-5 for jumper configuration)

For installations connected to Brooks secondary electronics, the card edge version must have the 5 volt reference enabled on pin 10 and the D-type version configured for external valve return. If the 5853E was shipped as a system with Brooks secondary electronics, then the electronics are already configured properly.

**Note:** To obtain access to the jumpers for the following options, the electronics cover can must be removed. Remove the can by removing the three screws and the valve connector. The can must be replaced before returning the unit to service.

**Soft Start**

Refer to figures 3-4 and 3-5. To enable soft start, place the red jumper on the controller printed circuit board at J2 in the right hand (ss) position.

To disable soft start, place the red jumper on the controller printed circuit board at J2 in the left hand (n) position.

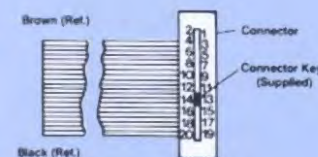

| PCB no. | Connector Pin No. | Function   | Color Code |
|---------|-------------------|--|------------|
| 1       | 1                 | Chassis Ground   | Brown      |
| A       | 2                 | Command Input (Command Pot 'S')                                | Red        |
| 2       | 3                 | 0-5 V Signal Common  | Orange     |
| B       | 4                 | Command Common (Command Pot 'CCW')                             | Yellow     |
| 3       | 5                 | 0-5 V Signal Output  | Green      |
| C       | 6                 | Supply Voltage Common  | Blue       |
| 4       | 7                 | + 15 Vdc Supply  | Violet     |
| D       | 8                 | Valve Test Point/Purge   | Gray       |
| 5       | 9                 | Remote Transducer Input***                                     | White      |
| E       | 10                | Not Used   | Black      |
| 6       | 11                | Not Used   | Brown      |
| F       | 12                | - 15 Vdc Input   | Red        |
| 7       | 13                | Slot   | Orange     |
| H       | 14                | Slot   | Yellow     |
| 8       | 15                | Not Used   | Green      |
| J       | 16                | Not Used   | Blue       |
| 9       | 17                | Valve Override   | Violet     |
| K       | 18                | Not Used   | Gray       |
| **      | 10                | + 5 V Reference Output (Command Pot 'CW')** or Valve Return*** | White      |
| L       | 20                | Valve Off  | Black      |

\*\* Jumper selectable  
\*\*\* Factory Activated Option

Figure 2-6 Card Edge Connector Hook-Up Diagram Models 5853E/5863E

## Remote set point (command) input

The command input hook-up is as follows:

### a. D-Connector

Connect the external command voltage to terminal 8 and external command return to terminal 1. Refer to figure 2-5.

### b. Card Edge

Connect the external command voltage to terminal A and external command return to terminal B. Refer to figure 2-5.

## Valve override

The valve override function allows full opening and closing of the valve independent of the command setting. The unique command reset feature prevents flow overshoot when the controller goes from valve override closed to normal control.

The valve override for mass flow controller is as follows:

- To open the valve, apply +15 Vdc to the valve override terminal.
- To close the valve, apply -15 Vdc to the valve override terminal.
- Isolating the valve override terminal returns the controller to normal operation.

## D-Connector

The valve override function is accessed from terminal 12. Refer to figure 2-5.

## Card-Edge

The valve override function can be accessed from terminal 9. Refer to figure 2-6.

## Valve test point

Refer to figures 2-5 and 2-6. One terminal of the valve coil is connected to the -15 Vdc supply through a protective diode. The voltage at the other terminal is modulated by the electronics and can be measured at pin D of the card edge version, pin 7 of the D-connector version, and at the valve voltage test point (TP3). This voltage relative to circuit common is proportional to the valve voltage per the following equation:

$$\text{Valve Voltage} = -14.2 - \text{Voltage at the valve voltage test point}$$

## Valve off

Refer to figures 2-5 and 2-6. The control valve can be forced closed regardless of command input signal by applying a TTL level low (<.4 Vdc) to terminal L of the card edge version or pin 4 of the D-connector version. A TTL level high or floating at this pin has no effect.

## 5-Volt reference output/ valve drive configuration

### a. D-Connector

Refer to figures 2-5 and 3-4. The 5 volt reference is always available on pin 11.

To minimize the effect of resistance in the connection wiring, a separate 'external valve return' can be accessed on pin 3. To enable this feature, place the black jumper at J3 in the B-D position and connect pin 3 to power supply common.

If the 'external valve return' is not enabled, place the black jumper at J3 in the B-C position.

**Note:** If the 'external valve return' feature is not enabled, the valve voltage is returned internally on the printed circuit board and the connection wiring resistance must be less than 0.2 ohms.

### b. Card Edge

Refer to figures 2-6 and 3-5. Terminal 10 can be jumper selected as 5 volt reference output, external valve return or 'not used'. The 5 volt reference output is required by Brooks secondary electronics or if a potentiometer is to be used to generate the command signal. To enable the 5 volt reference output on terminal 10, place the yellow jumper at J4 in the D-E position. To disable the 5 volt reference output, place the yellow jumper at J4 in the E-F position.

**CAUTION:** Do not ground terminal 10 when 5 volt reference output is enabled. Irreparable damage to the PC Board may result.

To minimize the effect of resistance in the connection wiring, a separate 'external valve return' can be accessed on pin 10. To enable this feature, place the black jumper at J3 in the B-D position and connect terminal 10 to power supply common. If the 'external valve return' is not enabled, place the black jumper at J3 in the B-C position.

**Note:** If the 'external valve return' feature is not enabled, the valve voltage is returned internally on the printed circuit board and the connection wiring resistance must be less than 0.2 ohms.

## 2-7 ELECTRICAL INTERFACING MODELS 5853i/5863i

### Electrical Interfacing

To ensure proper operation, the 5853i must be connected per figure 2-7 and configured according to section 2-7. As a minimum, the following connections must be made for new installations:

Function:

Chassis Ground  
Signal Output Return  
Voltage or Current Signal Output  
15-28 Vdc Supply  
Supply Common  
Voltage or Current Setpoint Input  
Setpoint Return

### Electrical Hook-Up Setpoint (Command) Input

The 5853i Mass Flow Controller can be used with a current (4-20 mA dc) or voltage (0-5 Vdc) setpoint. To use the current setpoint, connect the setpoint (+) signal to pin 7 and the setpoint return (-) signal to pin 1 of the D-connector and configure the PC board per section 2-7. To use the voltage setpoint, connect the setpoint signal to pin 8 and the voltage setpoint return to pin 1 of the D-connector and configure the PC board.

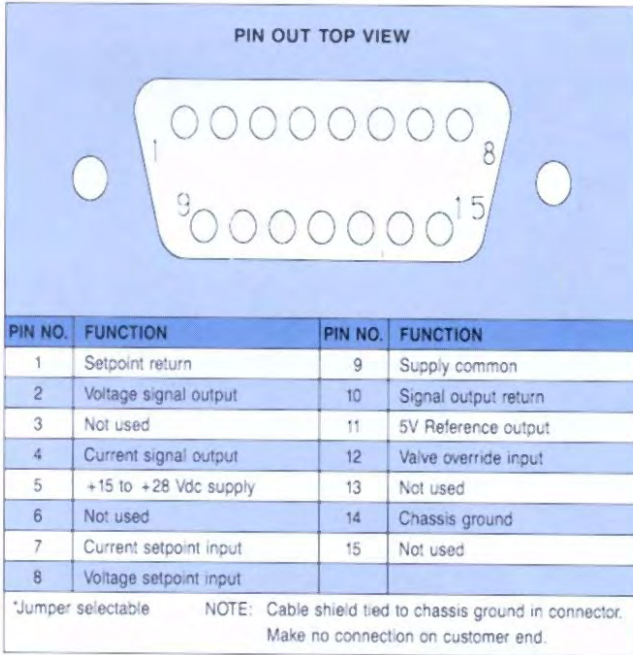

Figure 2-7 "D" Type Connector Pin Arrangement Models 5853i and 5863i

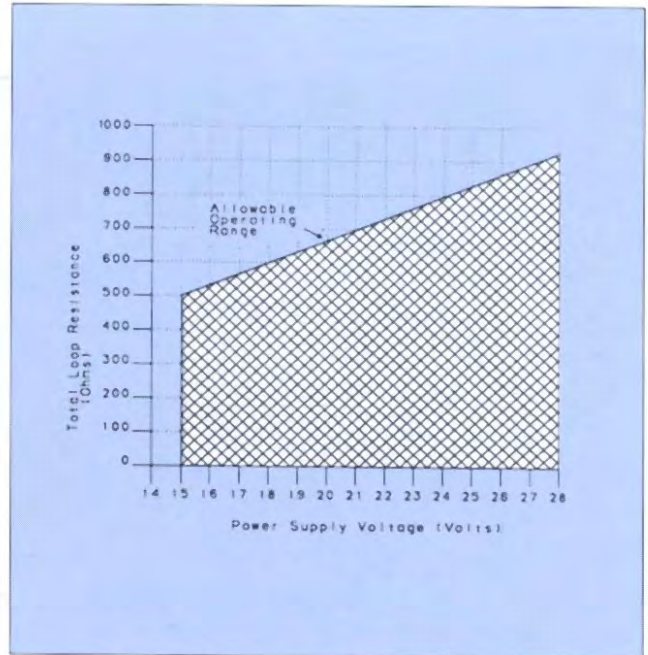

Figure 2-8 Maximum Allowable Loop Resistance

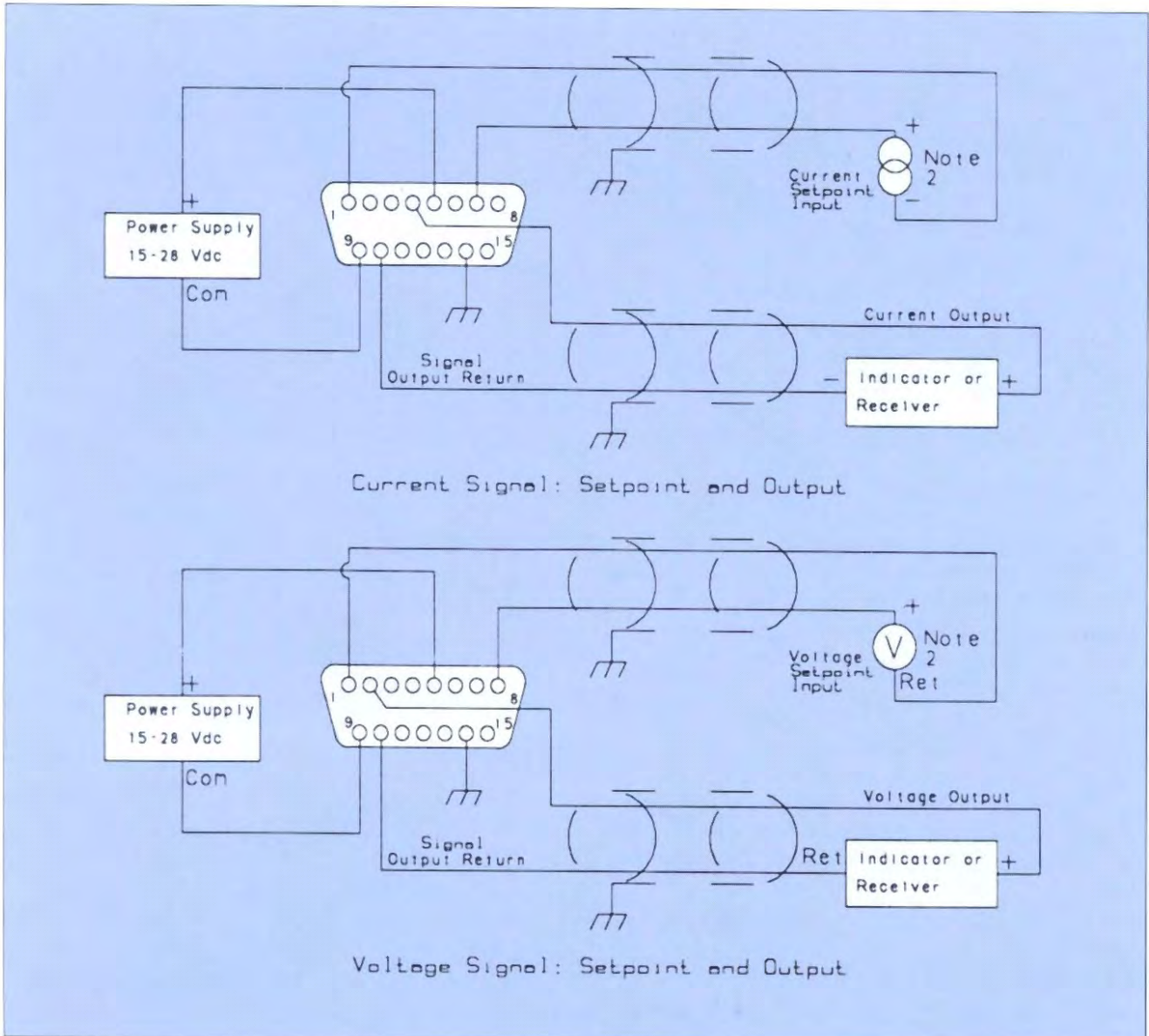

Figure 2-9 Common Electrical Hook-Ups Models: 5853i/5863i

## Signal Output

The flow signal output can be measured as a voltage or a current simultaneously on two different pins of the D-connector. Pin 2 indicates the flowrate with a 0-5 Vdc signal proportional to the mass flow rate. Pin 4 indicates the flowrate with either a 0-20 mAdc or 4-20 mAdc current signal as determined by jumpers on the PC board (refer to section 2-7 for jumper positions). Both the current and voltage signals are returned on pin 10 of the D-connector.

## Supply

The power for the mass flow controller is connected to pin 5 (+15 to +28 Vdc) and pin 9 (supply common) of the D-connector. Refer to section 1-3 for the power requirements.

### Note:

The length of wire for the power supply connections (pins 5 & 9) must be kept as short as possible to ensure the minimum voltage (+15) is available at the mass flow controller.

## Chassis Ground

Connect earth ground to pin 14 of the D-connector.

## Valve Override (connection optional)

The valve override function allows full opening and closing of the valve independent of the setpoint:

- To open the valve, apply +15 to +28 Vdc to pin 12
- To close the valve, connect pin 12 to ground
- Isolating pin 12 (no connection) returns the controller to normal operation

## Configuring the PC board

### Note:

To obtain access to the jumpers, the electronics must be removed. Disconnect the power to the mass flow controller, any cables to the D-connector and the valve coil connector. Remove the three screws at the base of the can and remove the top jack post of the D-connector. Remove the can. The can must be replaced before returning the unit to service.

Refer to figure 2-7 and 2-9 for the proper electrical hook-up. Refer to figure 3-6 for PC board jumper locations and functions.

## Setpoint (Command) Input

The mass flow controller can be configured for voltage or current setpoint (command) input. Jumper J7 (green) must be in the right-hand position for 0-5 Vdc setpoint and in the left-hand position for a 4-20 mAdc setpoint input.

## Signal Output

A 0-5 Vdc flow signal output is always available. The current signal output is jumper selectable for either 0-20 mAdc or 4-20 mAdc. Jumpers J3 and J4 (blue) must be in the upper position for 0-20 mAdc output and in the lower position for 4-20 mAdc output.

### Note:

Both J3 and J4 must be in the same position. Jumpers J3 and J4 do not affect the voltage output.

## Soft Start

To enable soft start, place Jumper J2 (red) in the right-hand position (SS). To disable soft start, place jumper J2 in the left-hand position (N).

**CAUTION:** *do not operate this instrument in excess of specifications listed in section 1-3. Before placing the unit into operation make sure all gas connections are tight and all electrical connections have been completed.*

## SECTION 3 OPERATION

### 3-1 THEORY OF OPERATION

The thermal mass flow sensing technique used in the 5853/5863 works as follows:

A precision power supply provides a constant power heat input (P) at the heater, which is located at the midpoint of the sensor tube. At zero or no flow conditions, the heat reaching each temperature sensor is equal. Therefore, the temperatures are equal. When gas flows through the tube, the upstream sensor (T1) is cooled and the downstream sensor (T2) is heated, producing a temperature difference. The temperature difference, T2-T1, is directly proportional to the gas mass flow.

The equation is:  $\Delta T = A * P * C_p * m$

Where:

$\Delta T$  = Temperature difference T2-T1 (K)

$C_p$  = Specific heat of the gas at constant pressure (kJ/kg-K)

P = Heater power (kJ/s)

m = Mass Flow (kg/s)

A = Constant of proportionality (S<sup>2</sup>-K<sup>2</sup>/kJ<sup>2</sup>)

A bridge circuit interprets the temperature difference and a differential amplifier generates a linear 0-5 Vdc signal directly proportional to the gas mass flow rate.

The flow restrictor performs a ranging function similar to a shunt resistor in an electrical ampere-meter.

The restrictor provides a pressure drop that is linear with flow rate. The sensor tube has the same linear pressure drop/flow relationship. The ratio of the restrictor flow to the sensor tube flow remains constant over the range of the meter. Different restrictors have different pressure drops and produce controllers with different full scale flow rates. The span adjustment in the electronics affects the fine adjustment of the controllers full scale flow.

In addition to the Mass Flow Sensor, the model 5853 Mass Flow Controller has an integral control valve and control circuit, as shown in figure 3-1. The control circuit senses any difference between the flow sensor signal and adjusts the current in the modulating solenoid valve to increase or decrease the flow.

Model 5853 has the following features incorporated in the integral control circuit:

- Fast Response is adjusted by the anticipate potentiometer. This circuit, when properly adjusted, allows the high frequency information contained in the sensor signal to be amplified to provide a faster responding flow signal for remote indication and use by the control valve.
- Soft Start is enabled by moving a jumper on the PC board. This circuit provides a slow injection of gas as a protection to the process, particularly those using a volatile or reactive gas. Full gas flow is achieved in proximately 15 seconds. Refer to section 2--6 and 2-7.

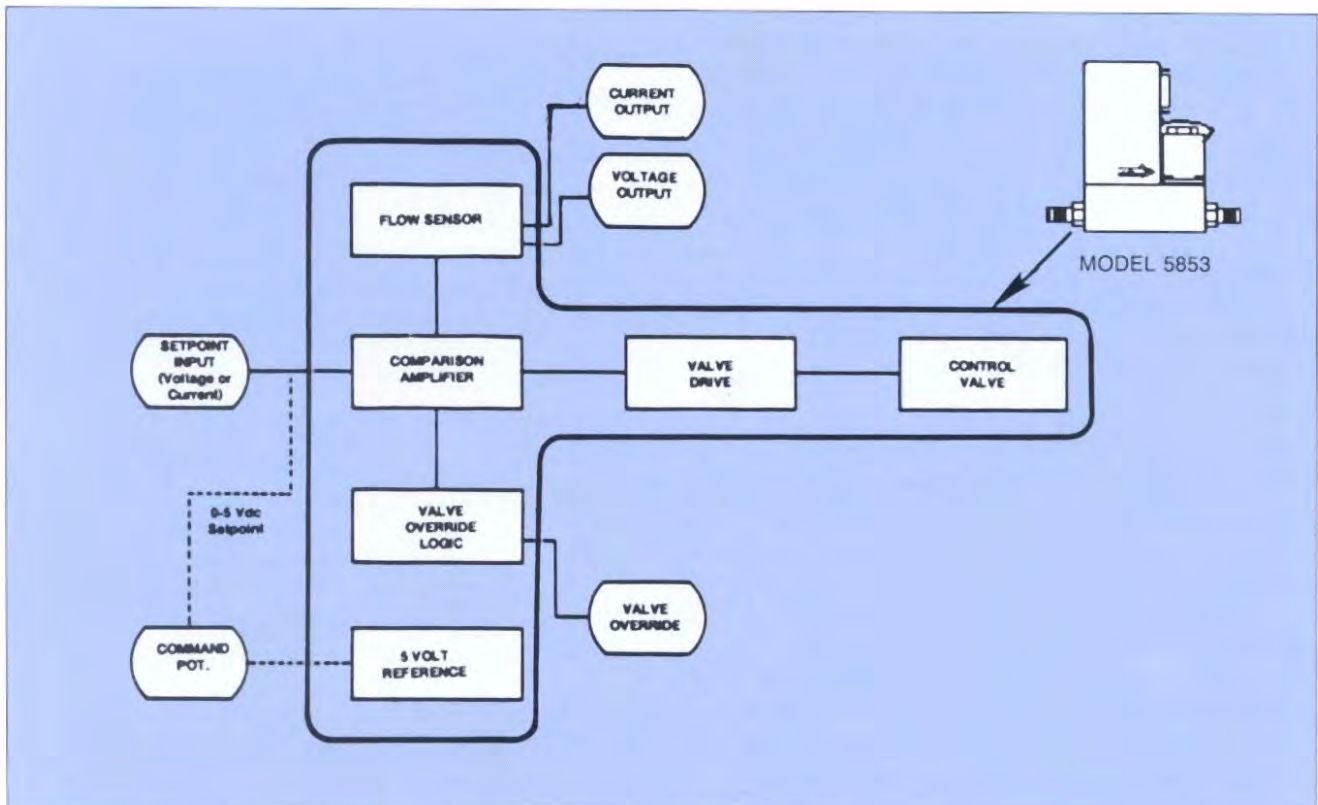

Figure 3-1 Flow Control System Block Diagram

- Precision 5 Volt Reference allows the direct connection of command potentiometer to produce a 0-5 volt command signal to the controller. A precision 10-turn 2 K ohm potentiometer with an integral turns counter is recommended. This will permit repeatable adjustments of setpoint to 1 part in 1000.
- Valve Override allows full opening and closing of the control valve independent of the command setting. Refer to the sections 2-6 and 2-7.

### 3-2 OPERATING PROCEDURE

- Apply power to the controller and allow approximately 45 minutes for the instrument to warm up and stabilize its temperature.
- Turn on the gas supply.
- Command 0% flow and observe the controller's output signal. If the output is not 0 mVdc ( $\pm 10$  mVdc), check for leaks and if none are found, refer to the re-zeroing procedure in section 3-3.
- Set the command for the desired flow rate to assume normal operation.

### 3-3 ZERO ADJUSTMENT

Each 5853/5863 is factory adjusted to provide a zero  $\pm 10$  mVdc signal or a 4 mAdc  $\pm .05$  mAdc signal at zero flow. The adjustment is made in our calibration laboratory which is temperature controlled to 21.1 °C. After initial installation and warm up in the gas system, the zero flow indication may be other than the factory setting. This is primarily caused by changes in temperature between our calibration laboratory and the final installation. The zero flow reading can also be affected to a small degree by changes in line pressure and mounting attitude.

To check zero, always mount the controller in its final configuration and allow a minimum of 20 minutes for the temperature of the controller and its environment to stabilize. Using a suitable voltmeter, check the controller output signal. If it differs from the factory setting, adjust it by removing the lower pot hole plug which is located closest to the controller body. Adjust the zero potentiometer (refer to figure 3-2) until the desired output signal is obtained.

#### Note:

If the 0-20 mA output is used, adjust zero by monitoring the voltage output signal. This is required because the current output cannot go negative.

### 3-5 RESPONSE

#### Fast response adjustment

Adjustment of the anticipate potentiometer to obtain a flow rate performance to be within 2% of flow rate commanded in less than three (3) seconds for the "E"-series and six (6) seconds for the "i"-series

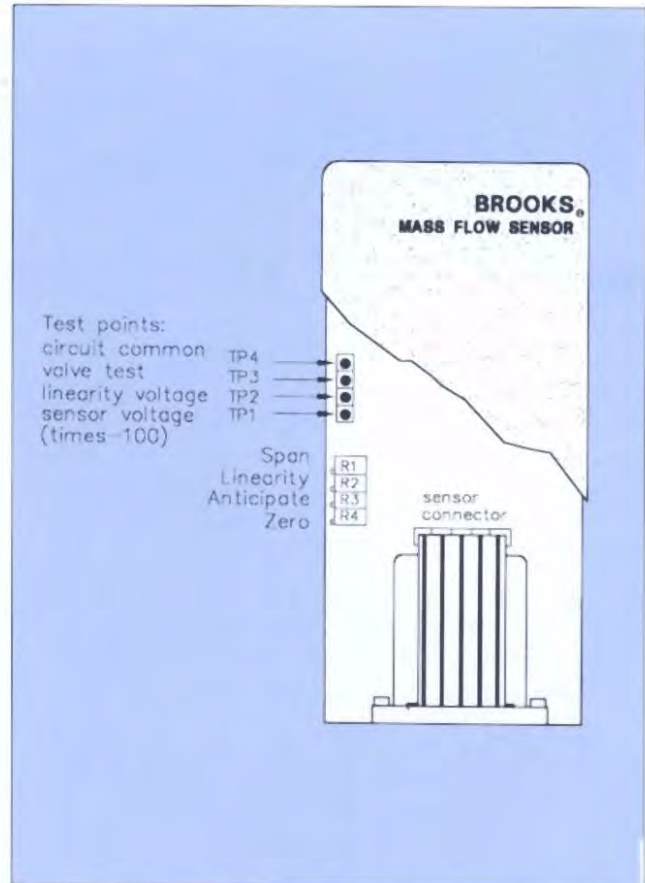

Figure 3-2 Adjustment Potentiometer Location

after set-point change requires the use of a fast response flowmeter (500 millisecond response to be within 0.2% of final value or better) in series with the 5853 and a storage oscilloscope or recorder.

- Allow the flow controller to stabilize at 0% setpoint for at least thirty seconds. Make a step in command to the controller from 0 to 100% of full scale flow and record the output signal of the fast response flowmeter.
- If this signal shows more than 4% overshoot, adjust the anticipate potentiometer one-half to one turn counterclockwise. If the signal does not show overshoot, but is not within 2% full scale of final value after 3 seconds, adjust the anticipate potentiometer one-half to one turn clockwise. Set command potentiometer for 0% of flow.
- Repeat steps a and b until the fast response flowmeter output signal meets the specified response requirements.

#### Note:

With the above equipment, the anticipate potentiometer can be adjusted to give optimum response characteristics for any process.

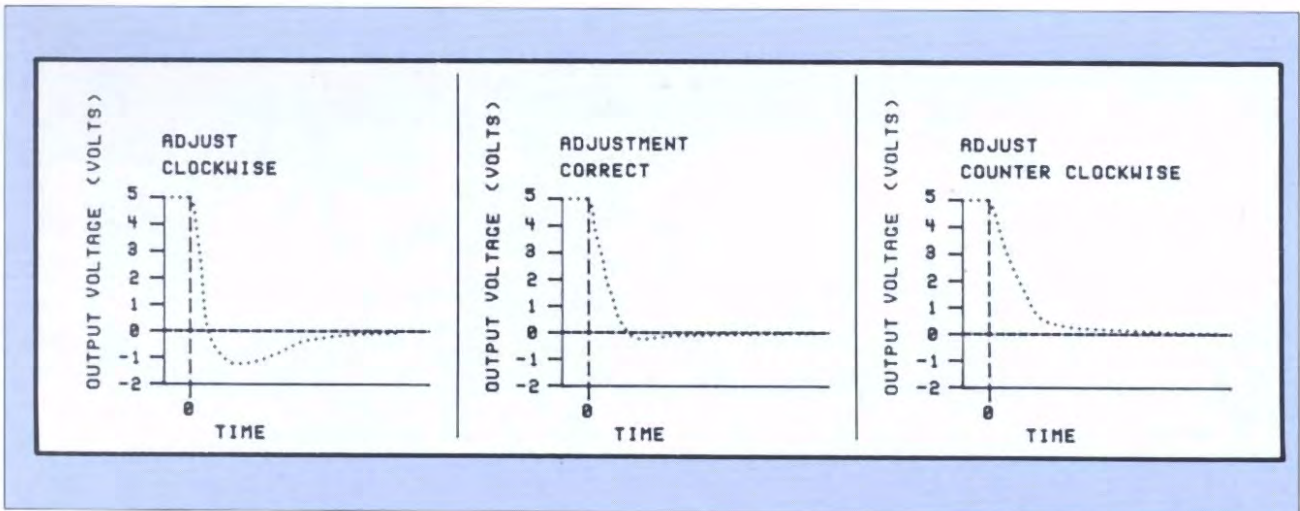

Figure 3-3 Fast Response Adjustment

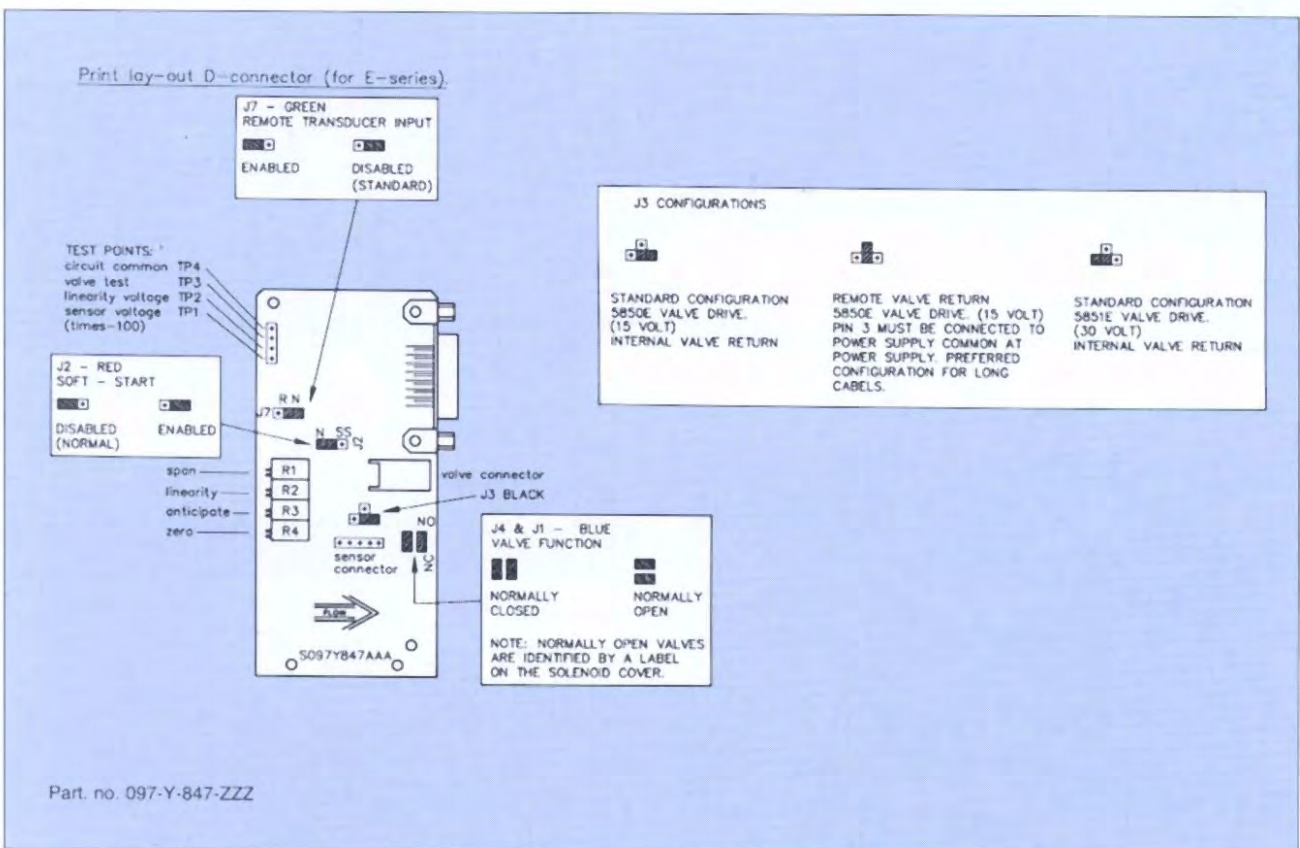

Figure 3-4 "D" Type Connector PC Board Jumper Location & Function Models 5853E/5863E

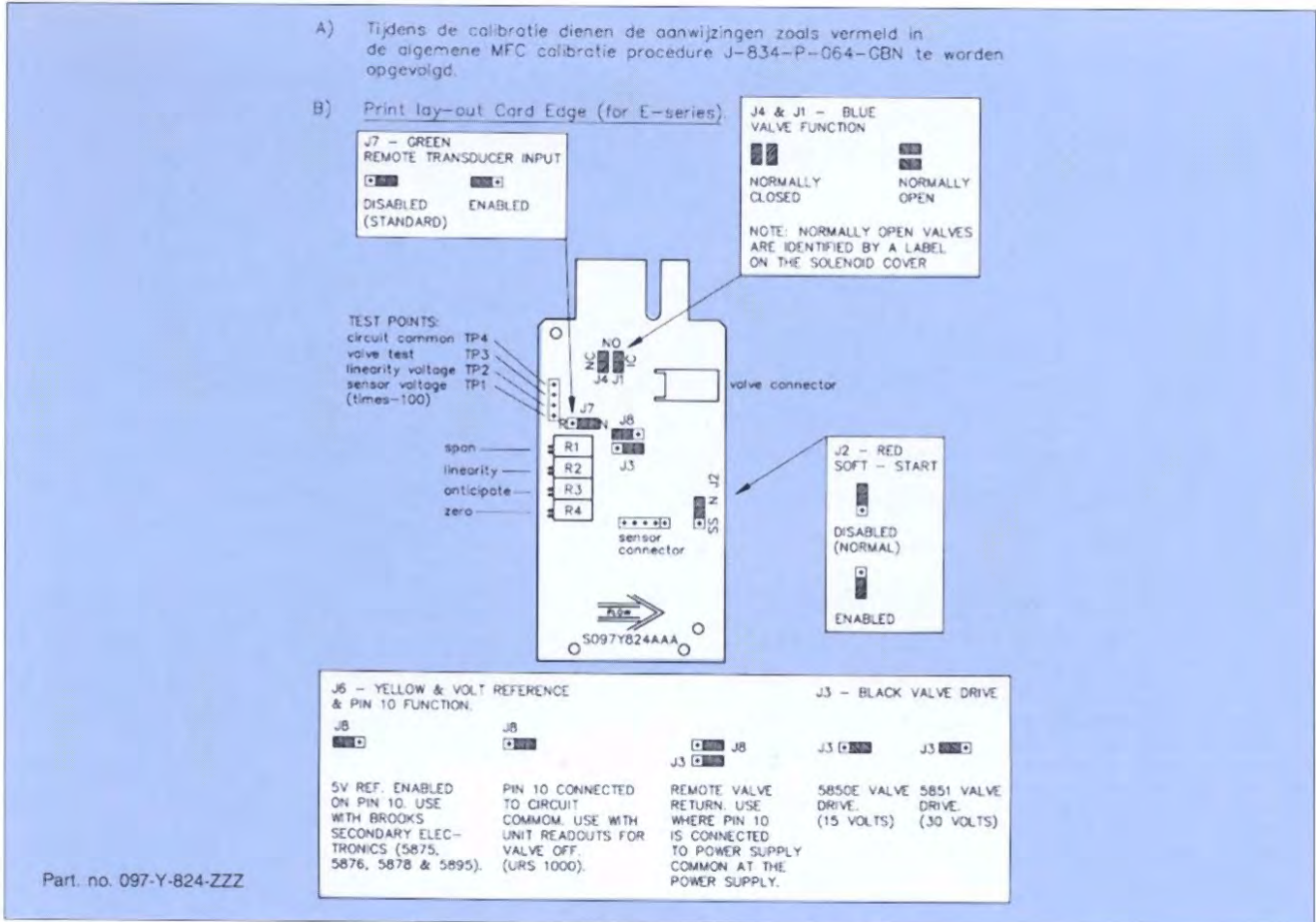

Figure 3-5 Card Edge PC Board Jumper Location & Function

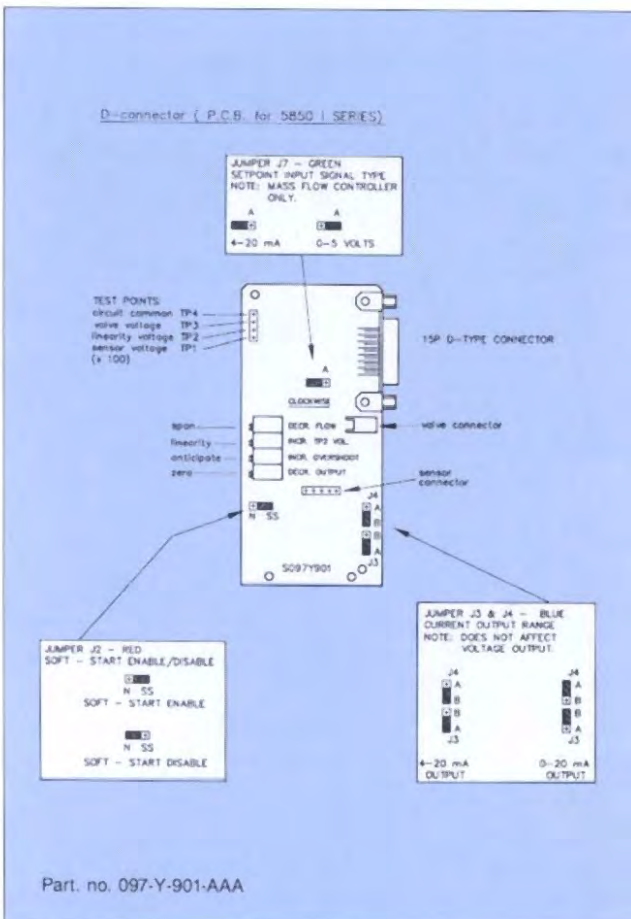

Figure 3-6 PC Board Jumper Location & Function Models 5853/5863i

## Section 4 MAINTENANCE

### 4-1 GENERAL

No routine maintenance is required on models 5853/5863 other than an occasional cleaning. The in-line filter should periodically be replaced or ultrasonically cleaned.

**CAUTION:** The Control valve assembly consists of an axial mounted main-valve driven by the topmounted pilot valve.

The main valve should not be disassembled. If required; please return the Mass Flow Controller to the factory. The specified procedures refer to the pilot valve only.

The Laminar flow element should not be removed. In case of recalibration more than 100  $l_n/min$  the M.F.M. or M.F.C. should be returned to the factory.



## 4-2 TROUBLESHOOTING

**CAUTION:** *It is important that this instrument be serviced only by properly trained and qualified personnel.*

### System Checks

The models 5853/5863 are generally used as a component in gas handling systems which can be quite complex. This can make the task of isolating a malfunction in the system a difficult one. An incorrectly diagnosed malfunction can cause many hours of unnecessary downtime. If possible, make the following system checks before removing a suspected defective mass flow controller for bench troubleshooting or return. Especially if the system is new.

1. Verify a low resistance common connection and that the correct power supply voltage and signals are reaching and leaving the controller.
2. Verify that the process gas connections have been correctly terminated and leak checked.
3. If the mass flow controller appears to be functioning, but cannot achieve setpoint, verify that sufficient inlet pressure and pressure drop are available at the controller to provide the required flow.
4. Verify that all user selectable jumpers are in their desired positions. Refer to figures 3-4, 3-5 or 3-6.

**WARNING:** *If it becomes necessary to remove the sensor/controller from the system after exposure to toxic, pyrophoric, flammable or corrosive gas, purge the controller thoroughly with a dry inert gas such as nitrogen before disconnecting the gas connections. Failure to correctly purge the controller could result in fire, explosion or death. Corrosion or contamination of the mass flow controller upon exposure to air may also occur.*

### Bench Troubleshooting

1. Properly connect the mass flow controller to a +15-28 Vdc power supply for the *i*-series and  $\pm 15$  Vdc for the E-series command voltage source and connect an output signal readout device (4 1/2 digit voltmeter recommended) to pins 2 and 10 of the D-connector. Apply power, set the setpoint to zero and allow the controller to warm up for 45 minutes. Do not connect to a gas source at this time. Observe the output signal and, if necessary, perform the zero adjustment procedure (section 3-3). If the output signal does not zero properly, refer to the sensor troubleshooting section and check the sensor. If the sensor is electrically functional, the printed circuit board is defective and needs replacement.
2. Connect the controller to a source of the gas on which it was originally calibrated. Adjust the setpoint for 100% flow and adjust the inlet and outlet pressures to the calibration conditions. Verify that the output signal reaches and stabilizes at 5.00

volts. Vary the command voltage over the 2 to 100% range and verify that the output signal follows the setpoint. Apply +15-28 volts (applicable for the *i*-series or  $\pm 15$  Vdc for the E-series) to the valve override input (pin 12) and verify that the output exceeds 100%. Connect the valve override pin to ground and verify that the output signal falls below 2%. If possible, connect a flow measurement device in series with the mass flow controller to observe the actual flow behavior and verify the accuracy of the mass flow controller. If the mass flow controller functions as described above, it is functioning properly and the problem may lie elsewhere.

Table 4-1 lists possible malfunctions which may be encountered during bench troubleshooting.

### Sensor Troubleshooting

If it is believed the sensor coils are either open or shorted, troubleshoot using table 4-2. If any of the steps do not produce the expected results, the sensor assembly is defective and must be replaced. Refer to section 4-4 for the disassembly and assembly procedures to use when replacing the sensor.

#### Note:

Do not attempt to disassemble the sensor

### Cleaning Procedures

Should the model 5853 Mass Flow Controller or Model 5863 Mass Flowmeter require cleaning due to deposition, use the following procedures:

Remove the unit from the system

**CAUTION:** *Do not soak the sensor assembly in a cleaning solution. If solvent seeps into the sensor assembly, it will probably damage the sensor, or at least significantly alter its operating characteristics.*

3. Use a hemostat or tweezers to push a 0.007" diameter piano wire through the flow sensor tube to remove any contamination. For best results push the wire into the downstream opening of the sensor tube (end closest to the control valve). The sensor tube can be flushed with a non-residuous solvent (Freon TF recommended). A hypodermic needle filled with solvent is a convenient means to accomplish this.

**Table 4-1 Bench Troubleshooting Models 5853 and 5863**

| Trouble   | Possible Cause   | Check/Corrective Action   |
|---|--|---|
| Actual flow overshoots set-point by more than 5% full scale   | Anticipate potentiometer out of adjustment   | Adjust anticipate potentiometer. Refer to section 3-5.  |
| Output stays at zero regardless of setpoint and there is no flow through the controller               | Clogged Sensor Procedure, section 4-4<br>Clogged Control Valve<br><br>Valve override input is grounded<br>Defective PC board   | Clean sensor. Refer to cleaning procedures.<br><br>Check TP3 with the setpoint at 100%. If the voltage is greater than 11V, disassemble and repair the control valve. Refer to section 4-4<br>Check the valve override input (pin 12)<br><br>Replace PC board. Refer to section 4-4 |
| Output signal stays at +6.8V or 26 mA regardless of setpoint and there is flow through the controller | Valve stuck open or leaky<br><br>+15V -28Vdc applied to the valve override input<br>Defective PC Board   | Clean and/or adjust control valve. Refer to cleaning procedures and/or section 4-4C<br>Check the valve override terminal (pin 12)<br><br>Replace PC board. Refer to section 4-4   |
| Output signal follows setpoint at higher setpoints but will not go below 2% (8% for all-metal seal)   | Leaky control valve  | Disassemble and repair valve.<br>Refer to section 4-4   |
| Output signal follows setpoint at lower setpoints, but does not reach full scale                      | Insufficient inlet pressure or pressure drop<br>Partially clogged sensor<br>Partially clogged valve<br>Valve out of adjustment<br>Valve guide spring failure                               | Adjust pressures, inspect in-line filters and clean/replace as necessary<br>Check calibration. Refer to section 3-4<br>Disassemble and repair control valve. Refer to section 4-4<br>Adjust valve. Refer to section 4-4<br>Controller oscillates (see below)                        |
| Controller grossly out of calibration. Flow is higher than desired                                    | Partially clogged sensor   | Clean sensor, refer to the cleaning procedures  |
| Controller grossly out of calibration. Flow is lower than desired                                     | Partially clogged restrictor   | Replace restrictor. Refer to section 4-4  |
| Controller oscillates   | Pressure drop or inlet pressure excessive<br>Oversized orifice<br>Valve out of adjustment<br>Anticipate potentiometer out of adjustment<br>Faulty pressure regulator<br>Defective PC board | Adjust pressures<br><br>Check orifice size.<br>Adjust valve. Refer to section 4-4<br>Adjust anticipate potentiometer. Refer to section 3-5<br>Check regulator output<br>Replace PC board. Refer to section 4-4  |

### 4-3 SENSOR TUBE

The sensor tube is part of a calibrated flow divider that is designed to operate within a preset gas flow range. The sensor assembly may be removed or replaced. If the sensor assembly is cleaned and reinstalled, a calibration check should be performed.

Table 4-2 Sensor Troubleshooting

**SENSOR SCHEMATIC**

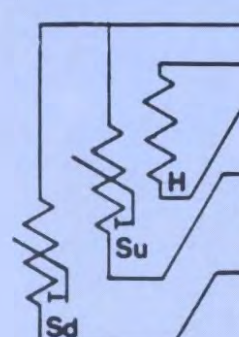

| PIN NO. | FUNCTION                           |
|---------|------------------------------------|
| 4       | Sensor Common                      |
| 1       | Heater                             |
| 5       | Heater Common                      |
| 2       | Upstream Temperature Sensor (Su)   |
| 3       | Downstream Temperature Sensor (Sd) |

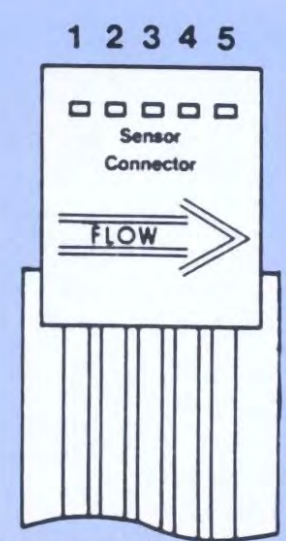

Flex Circuit Wire Numbers

| Ohmmeter Connection         | Result if Electrically Functional  |
|-----------------------------|--|
| Pin 1 or 4 to Body (Ground) | Open circuit on ohmmeter. If either heater or sensor common are shorted, an ohmmeter reading will be obtained. |
| Pin 4 to pin 2              | Nominal 1100 ohms reading, depending on temperature and ohmmeter current.                                      |
| Pin 4 to pin 3              |  |
| Pin 5 to pin 1              | Nominal 1200 ohm reading   |

**Note:** This table refers to the models 5853E or *i* and 5863E or *i*.  
Please remove the sensor connector from the PC board for this procedure

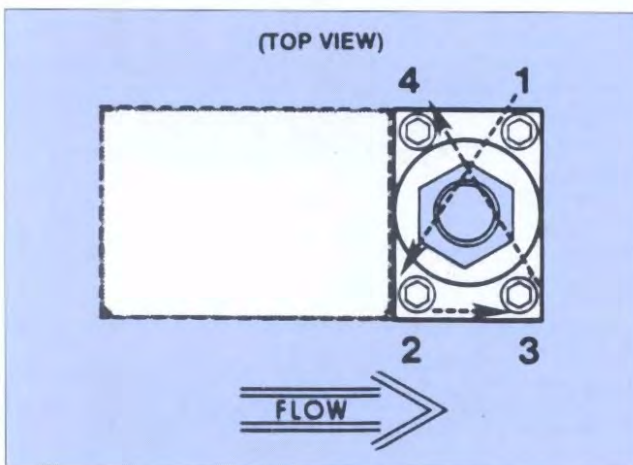

Figure 4-1 Torque Sequence for the Pilot Valve Retainer Plate

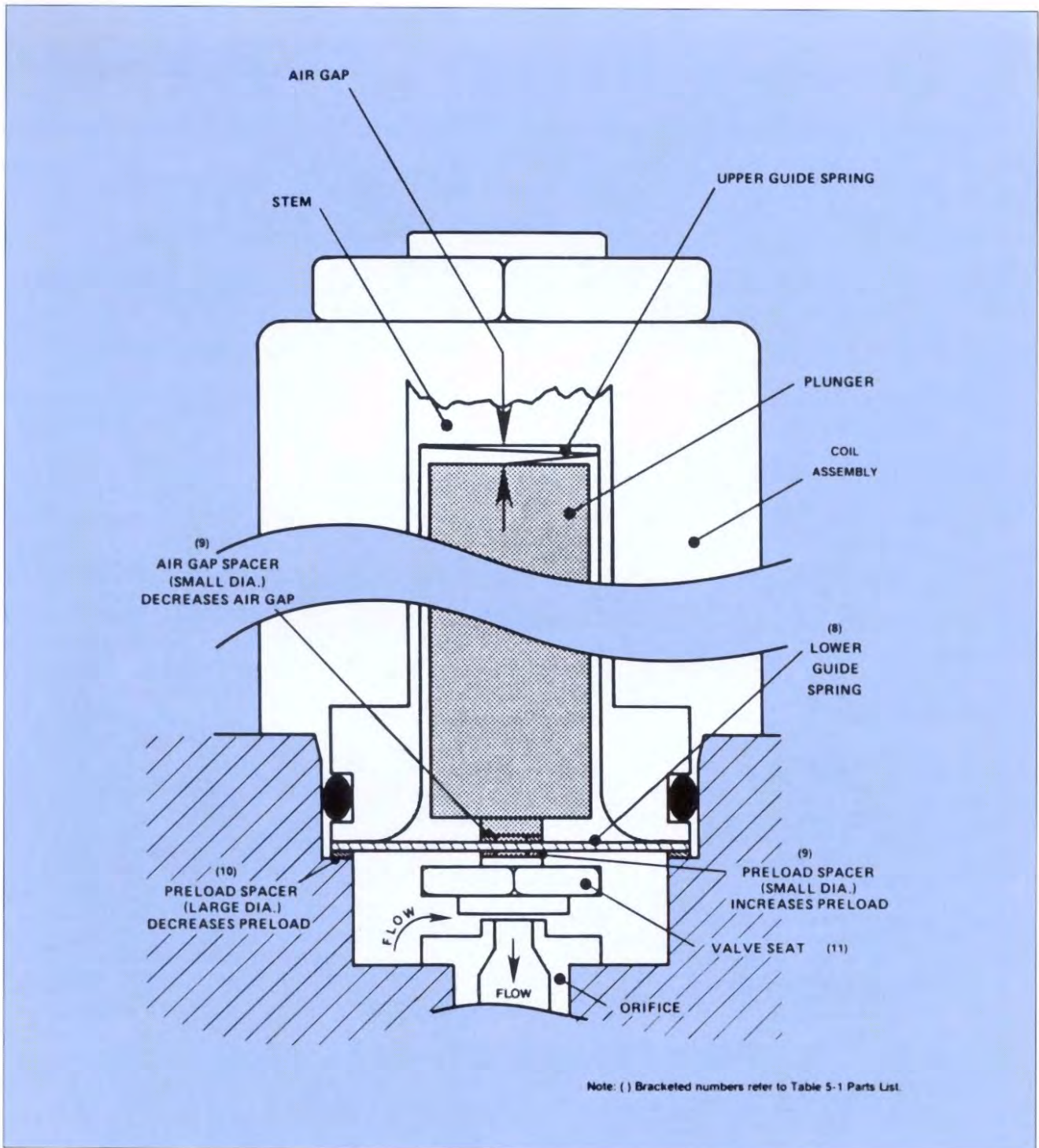

Figure 4-2 Pilot Valve Adjusting Spacer Locations

#### 4-4 DISASSEMBLY AND ASSEMBLY

**CAUTION:** *The laminar flow element should not be removed. In case of recalibration more than 100  $I_N/min$ , the M.F.M. or M.F.C. should be returned to the factory.*

Model 5853 Mass Flow Controller or Model 5863 Mass Flowmeter may be disassembled in the field by the user for cleaning, reranging or servicing. Disassemble and assemble the controller as follows:

##### A. Disassembly

The numbers in parentheses refer to the spare parts Assembly drawing in figure 5-1.

1. Remove the jam nut (6) on top of the valve assembly.
2. Unplug the valve connector (34) from the electronics cover and remove the coil assembly (4).
3. Remove the hex socket screws (22) securing the valve retaining plate (7) attaching the valve stem assembly (3).

4. Carefully remove the valve stem assembly (3).
5. Remove the plunger assembly (7, 12, 13)
6. Remove and note the position of the valve spring spacers, which may be located above and/or below the lower valve springs (13).
7. Unscrew the orifice (12) from the flow controller body (30).
8. Carefully unscrew the valve seat (30) from the plunger (11). Note the position and number of spacers and springs (8) that are stacked on the threaded end of the valve seat.
9. Remove the three screws (21) attaching the electronics cover. Remove the upper jack post on the D-connector. Remove the electronics cover (2).

**CAUTION:** *Be careful not to stress the sensor lead wire to sensor assembly junction when removing the sensor connector from the PC board. If the sensor lead wires are stressed an open in the sensor wiring could result.*

10. Unplug the sensor connector from the PC board. Remove the two screws (21) securing the bracket (10) and PC board (8). Remove the bracket and PC board.
11. Remove the two screws (23) securing the sensor assembly (9). Remove the sensor assembly.

**Note:**

Do not attempt to disassemble the sensor assembly.

**CAUTION:** *Do not scratch the O-ring sealing surface.*

12. Remove the sensor assembly O-rings (18) from the flow controller body (1). Using the Brooks O-Ring removal tool will help prevent scratching the sealing surface.
13. Remove the inlet plate adapter (32) from the flow controller body.
14. Remove the restrictor assembly (31) from the inlet side of the flow controller body.

**B. Assembly**

**CAUTION:** *Do not get Halocarbon lubricant on the restrictor element (9) or hands. This is a special inert lubricant which is not easily removed.*

**Note:**

It is recommended that all O-rings be replaced during controller assembly. All O-rings should be lightly lubricated with Halocarbon lubricant (part of O-ring kit, section 5) prior to their installation.

1. Examine all parts for signs of wear or damage, replace as necessary.

2. Place the restrictor assembly (31) into the inlet side of the flow controller body.

**CAUTION:** *The following steps must be performed as written. Placing the O-rings on the sensors before it is installed, will result in damage to the O-rings causing a leak.*

3. Press the lubricated sensor O-rings (18) into the flow controller body (1). Install the sensor assembly and secure with two screws (23) and tighten.
4. Install the orifice (30) and its O-ring, using a 3/8 nut driver. Insure that the orifice is fully seated but do not overtighten.
5. Insert the pilot valve preload spacers, if used, into the valve cavity in the flow controller body. Use care to preserve the correct order.
6. Place the spacers and springs on the valve seat (12) in the same order as noted in Step 8 of the disassembly. Screw the valve seat (12) in the same order as noted in step 8 of the disassembly. Screw the valve seat (12) into the plunger (4). Tighten the assembly until there is no looseness but do not overtighten.
7. Install the pilot valve plunger assembly (7, 12 and 13) on the preload spacers. Install air gap spacers, if used, on top of the valve springs.
8. Install the pilot valve stem assembly (3), secure with the valve retaining plate (7) and four hex socket screws (22). When installing the screws they should first make light contact with the plate which should be checked to insure that it makes full contact around the stem assembly. Torque the screws securing the valve retaining plate in a diagonal pattern (refer to figure 4-1) to 1.9 Nm.
9. Install the coil assembly (4) over the valve stem assembly (3) and secure with nut (6).
10. Install the PC board (8) and secure with the bracket (10) and two screws. Plug the connector from the sensor assembly onto the PC board. The flow arrow on the connector should be pointing toward the valve assembly.
11. Install the electronics cover (2) on the controller, secure with three screws (21) and reinstall the upper jack post of the D-connector. Plug the sensor from the valve coil into the PC board through the hole in the electronics cover.
12. Prior to installation leak and pressure test to any applicable pressure vessel codes.

**C. Adjusting the Pilot Control Valve**

The pilot control valve has been factory adjusted to ensure proper operation. Readjustment is only required if any of the following parts have been replaced:

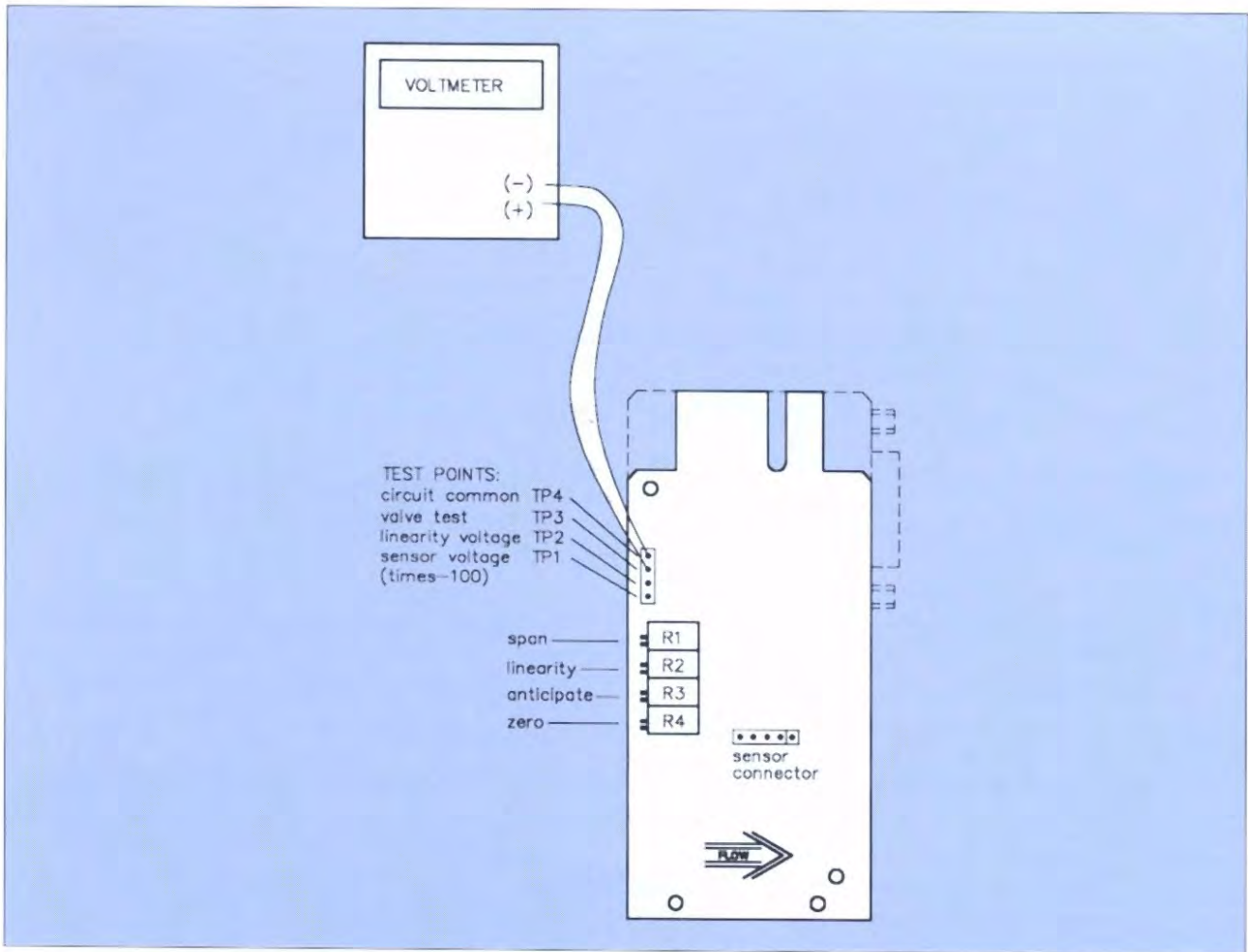

Figure 4-3 Voltmeter Connections for Valve Adjustment

- orifice (30)
- valve stem (3)
- plunger (11)
- lower guide springs (13)
- valve seat (12)

The valve is adjusted in Brooks mass flow controllers by adding spacers to the control valve assembly to vary the air gap and initial preload. Spacers are used to affect the proper adjustment because they provide a reliable and repeatable means for adjustment. Screw type adjustment mechanisms can change with pressure or vibration and introduce an additional dynamic seal that is a potential leak site and source for contamination. Refer to figure 4-2 for spacer locations.

The preload determines the initial force that is required to raise the valve seat off the orifice and start gas flow. If the preload is insufficient, the valve will not fully close and gas will leak-thru. If the preload is excessive, the magnetic force generated between the plunger and stem will be insufficient to raise the plunger and the valve will not open.

The airgap is the space between the plunger and stem. The airgap determines the force between the plunger and stem at a given voltage and the total

travel of the valve. If the airgap is too small, the plunger travel may be insufficient to fully open the valve, also the magnetic force may be too high for a given valve coil voltage. If the airgap is too large, the magnetic force may be too high for a given valve coil voltage. If the airgap is too large, the magnetic force will be insufficient to raise the plunger and the valve will not open.

**Note:**

Prior to starting the valve adjustment procedure check to ensure that the orifice is properly seated and that the valve parts are not bent or damaged.

The orifice size for the pilot control valve (30) is effected by the flow, process gas and pressure conditions. The correct pilot control valve orifice has been selected at the factory for the conditions given at the time of ordering. The pilot control valve orifice should always be replaced with one of the same size. Please consult the factory if the actual operating conditions are significantly different than the conditions to which the instrument was ordered. They will recommend the proper orifice for the pilot control.

### Adjustment Procedure

(refer to section 5: Spare Parts for the Spacer Kit)

- Remove the electronics cover (2) from the controller. Ensure that the connector from the coil assembly (34) is properly connected to the PC board after the electronics cover is removed.
- Perform the electrical and gas connections to the controller following the instructions in section 2 of this manual. Use a clean dry inert gas, such as nitrogen for this procedure. Do not apply gas pressure to the controller at this time.
- Disassemble the control valve following the procedure given in section 4-4A. Note the number, locations and thickness of all spacers.
- Decrease the preload of the valve by 0.05 mm by either removing a 0.05 mm small preload spacer or by adding a 0.05 mm large preload spacer and 0.2 mm small preload spacer. Refer to figure 4-2.
- Reassemble the valve following the assembly procedure in section 4-4B.
- Adjust setpoint for zero percent flow, apply normal operating pressure and check for valve lead-through by observing the output signal.
- If the valve leaks through, increase the preload by 0.05 mm, go to step h. If the valve does not leak through, repeat steps d, e, f and g.
- Apply normal operating gas pressure and adjust setpoint for 100% flow.

### Note:

Due to possible heat capacity and density differences between the test gas and actual process gas for which the MFC was sized, it may be necessary to increase the inlet pressure to obtain proper control at 100% flow.

- Measure the valve voltage by connecting a voltmeter between test point 3 (TP3) and test point 4 (TP4). Refer to figure 4-3.
- If the flow controller output signal is 100% (5.0V) and the valve voltage is less than 11.5V, the valve adjustment is complete.
- If the flow controller output signal is 100% and the valve voltage is greater than 11.5V, decrease the air gap with a small 0.05 mm air gap spacer. Refer to figure 4-2. Repeat steps h and i.
- If the flow controller output signal is less than 100% and the valve voltage is greater than 11.5V, this condition indicates that the inlet pressure is too low and/or the orifice size is too small. First check section 4-6 to insure that the orifice size is correct.
- Proceed to section 3 and perform '3-4 Calibration Procedure', if required.

### 4-5 USE OF THE CONVERSION TABLES

If a mass flow controller is operated on a gas other than the gas it was calibrated with, a scale shift will occur in the relationship between the output signal and the mass flow rate. This is due to the difference in heat capacities between the two gases. This scale shift can be approximated by using the ratio of the molar specific heat of the two gases, or sensor conversion factor. A list of sensor conversion factors is given in table 4-3. To change to a new gas, multiply the output reading by the ratio of the gas factor for the desired gas to the gas factor for the calibration gas.

$$\text{Actual gas flow rate} = \text{Output reading} \times \frac{\text{factor of the new gas}}{\text{factor of the calibrated gas}}$$

Example:

The controller is calibrated for nitrogen  
The desired gas is carbon dioxide  
The output reading is 750 ml<sub>n</sub>/min when carbon dioxide is flowing

$$\text{Then } 750 \times 0.78 = 585.0 \text{ l}_n/\text{min}$$

In order to calculate the conversion factor for a gas mixture the following formula should be used:

$$\text{Sensor conversion factor Mixture} = \frac{100}{\frac{P_1}{\text{sensor conversion factor 1}} + \frac{P_2}{\text{sensor conversion factor 2}} + \frac{P_n}{\text{sensor conversion factor n}}}$$

Where P1 = percentage (%) of gas 1 (by volume)  
P2 = percentage (%) of gas 2 (by volume)  
Pn = percentage (%) of gas n (by volume)

Example:

The desired gas is 20% Helium (He) and 80% Chlorine (Cl) by volume. The desired full scale flow rate of the mixture is 200 l<sub>n</sub>/min.

Sensor conversion factor for the mixture is:

$$\text{Mixture Factor} = \frac{100}{\frac{20}{1.39} + \frac{80}{.83}} = .903$$

$$\text{Air equivalent flow} = 200/.903 = 221.5 \text{ l}_n/\text{min}$$

It is generally accepted that the mass flow rate derived from this equation is only accurate to  $\pm 5\%$ . The sensor conversion factors given in table 4-3 are calculated based on a gas temperature of 21 °C and a pressure of one atmosphere. The specific heat of most gases are not strongly pressure and temperature dependent, however, gas conditions that vary widely from these reference conditions may cause an additional error due to the change in specific heat due to temperature and/or pressure.

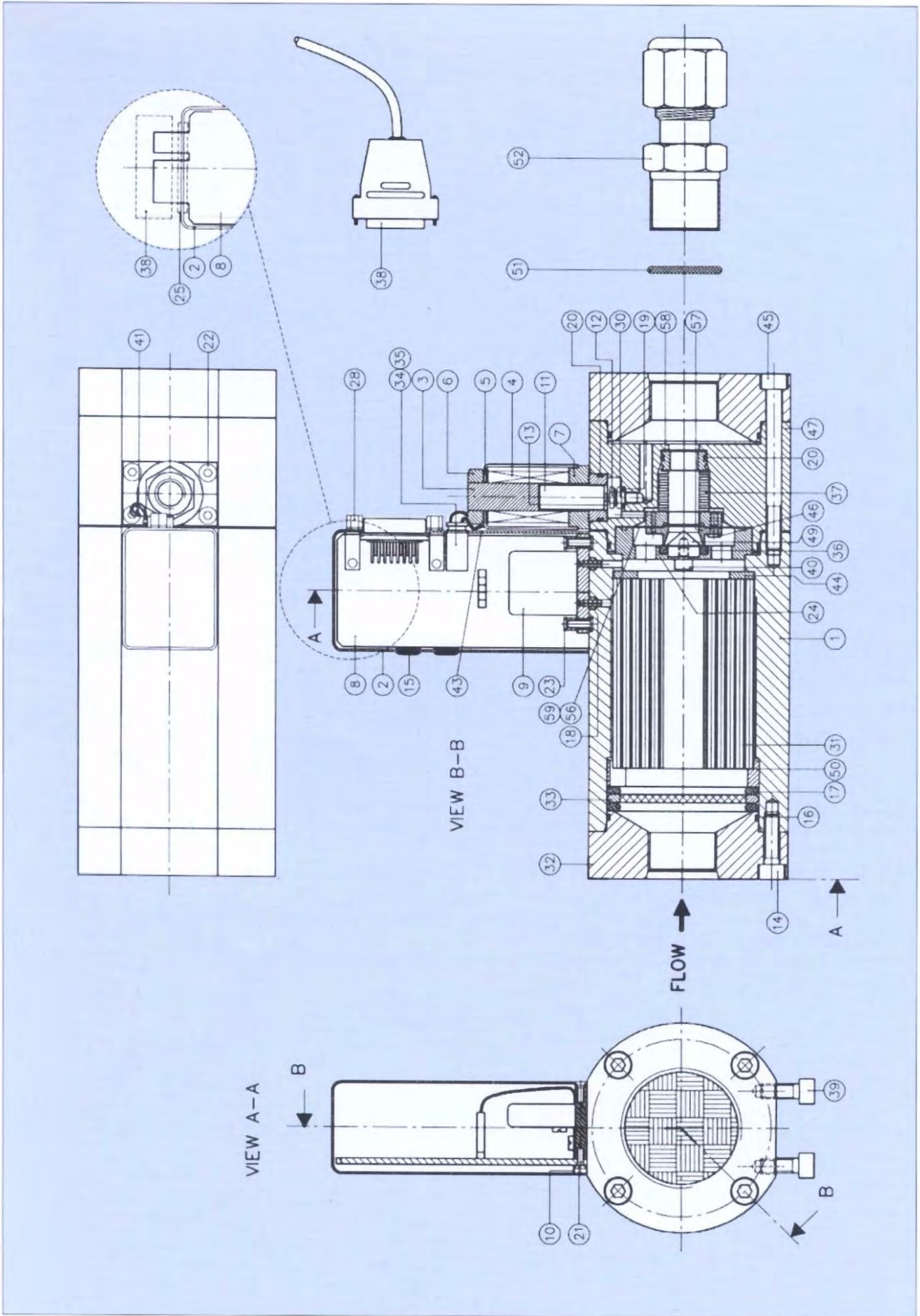

Figure 5-1 Model 5853 Parts Drawing



**Table 5-1 Model 5853, 5863 Replacement Parts List**

| Item No. | Qty. | Description  | Part Number   |
|----------|------|--|---|
| 1        | 1    | Meter Body (5863)  | 092-B-166-BMA   |
| 2        | 1    | Electronics Cover 5863E<br>5863 <i>i</i><br>5853E (CE)<br>5853E (D)<br>5853 <i>i</i>                         | 219-Z-347-EAD<br>219-Z-349-EAD<br>219-Z-250-EAD<br>219-Z-346-EAD<br>219-Z-348-EAD |
| 8        | 1    | P.C. Board Assy [D] series 5853E/5863E<br>[CE] series 5853E/5863E<br>[D] series 5853 <i>i</i> /5863 <i>i</i> | 097-Y-847-AAA<br>097-Y-824-AAA<br>097-Y-901-AAA                                   |
| 9        | 1    | Sensor Assembly  | 774-Z-508-BMA   |
| 10       | 1    | P.C. Board Mounting Bracket  | 079-Z-135-AAA   |
| 11       | 1    | Valve Plunger Assy   | 622-Z-165-AAA   |
| 12       | 1    | Valve Seat with Viton insert<br>Buna insert<br>Kalrez insert<br>Teflon insert                                | 715-Z-245-AAA<br>715-Z-246-AAA<br>715-Z-163-AAA<br>715-Z-049-AAA                  |
| 13       | 1    | Lower Guide Spring   | 820-Z-083-BMA   |
| 14       | 4    | Soc. Hd. Screw M6x20   | 760-C-159-AAZ   |
| 15       | 2    | Pot Hole Plug  | 620-Z-434-SXA   |
| 16       | 2    | O-ring Inlet plate   | 375-B-035-***   |
| 17       | 2    | O-ring Inlet filter  | 375-B-227-***   |
| 18       | 2    | O-ring, Sensor, size 004   | 375-B-004-***   |
| 33       | 1    | Inlet filter   | 306-Z-142-BMA   |
| 51       | 2    | O-ring, Compr. fittings  | 375-B-912-***   |
| 52       | 2    | Compression Fittings, 1 <sup>1</sup> / <sub>16</sub> - 12 to<br>1/2" tube<br>3/4" tube<br>1" tube            | 320-B-098-BMA<br>320-B-099-BMA<br>320-B-100-BMA                                   |

\*\*\* QTA-Viton, SUA-Buna, QMA-PTFE, TTA-Kalrez

| Item No. | Qty. | Interconnection Cables:  | Length             | Part Number   |
|----------|------|--|--------------------|---|
| NS       | 1    | D-Connector on one end with Connector for Secondary Electronics on other end | 3 m<br>6 m<br>12 m | S-124-Z-236-AAA<br>S-124-Z-237-AAA<br>S-124-Z-610-AAA |

\*\*\* QTA-Viton, SUA-Buna, TTA-Kalrez

## 5-1 General

This section contains the procedures for the receipt and installation of the instrument. See Section 2 for dimensional and connection requirements. Do not attempt to start the system until the instrument has been permanently installed. It is important that the start-up procedures be followed in the exact sequence presented.

## 5-2 Receipt of Equipment

When the instrument is received, the outside packing case should be checked for damage incurred during shipment. If the packing case is damaged, the local carrier should be notified at once regarding his liability. A report should be submitted to your nearest Product Service Department.

### Brooks Instrument

407 W. Vine Street  
 P.O. Box 903  
 Hatfield, PA 19440 USA  
 Toll Free (888) 554-FLOW (3569)  
 Tel (215) 362-3700  
 Fax (215) 362-3745  
 E-mail: BrooksAm@BrooksInstrument.com  
 www.BrooksInstrument.com

### Brooks Instrument

Neonstraat 3  
 6718 WX Ede, Netherlands  
 P.O. Box 428  
 6710 BK Ede, Netherlands  
 Tel 31-318-549-300  
 Fax 31-318-549-309  
 E-mail: BrooksEu@BrooksInstrument.com

### Brooks Instrument

1-4-4 Kitasuna Koto-Ku  
 Tokyo, 136-0073 Japan  
 Tel 011-81-3-5633-7100  
 Fax 011-81-3-5633-7101  
 Email:BrooksAs@BrooksInstrument.com

Remove the envelope containing the packing list. Carefully remove the instrument from the packing case. Make sure spare parts are not discarded with the packing materials. Inspect for damaged or missing parts.

## 5-3 Recommended Storage Practice

If intermediate or long-term storage of equipment is required, it is recommended that the equipment be stored in accordance with the following:

- a. Within the original shipping container.
- b. Stored in a sheltered area, preferably a warm, dry, heated warehouse.
- c. Ambient temperature of 70° F (21° C) nominal, 109° F (43° C) maximum, 45° F (7° C) minimum.
- d. Relative humidity 45% nominal, 60% maximum, 25% minimum.

Upon removal from storage a visual inspection should be conducted to verify the condition of equipment is "as received".

## 5-4 Return Shipment

Prior to returning any instrument to the factory visit the Brooks website [www.BrooksInstrument.com](http://www.BrooksInstrument.com) for a Return Materials Authorization Number (RMA#), or contact one of the following locations:

### Brooks Instrument

407 W. Vine Street  
P.O. Box 903  
Hatfield, PA 19440 USA  
Toll Free (888) 554-FLOW (3569)  
Tel (215) 362-3700  
Fax (215) 362-3745  
E-mail: [BrooksAm@BrooksInstrument.com](mailto:BrooksAm@BrooksInstrument.com)  
[www.BrooksInstrument.com](http://www.BrooksInstrument.com)

### Brooks Instrument

Neonstraat 3  
6718 WX Ede, Netherlands  
P.O. Box 428  
6710 BK Ede, Netherlands  
Tel 31-318-549-300  
Fax 31-318-549-309  
E-mail: [BrooksEu@BrooksInstrument.com](mailto:BrooksEu@BrooksInstrument.com)

### Brooks Instrument

1-4-4 Kitasuna Koto-Ku  
Tokyo, 136-0073 Japan  
Tel 011-81-3-5633-7100  
Fax 011-81-3-5633-7101  
Email: [BrooksAs@BrooksInstrument.com](mailto:BrooksAs@BrooksInstrument.com)

Instrument must have been purged in accordance with the following:

### WARNING

**Before returning the device purge thoroughly with a dry inert gas such as Nitrogen before disconnecting gas connections. Failure to correctly purge the instrument could result in fire, explosion or death. Corrosion or contamination may occur upon exposure to air.**

All flow instruments returned to Brooks requires completion of Form RPR003-1, Brooks Instrument Decontamination Statement, along with a Material Safety Data Sheet (MSDS) for the fluid(s) used in the instrument. Failure to provide this information will delay processing by Brooks personnel. Copies of these forms can be downloaded from the Brooks website [www.BrooksInstrument.com](http://www.BrooksInstrument.com) or are available from any Brooks Instrument location listed above.

## 5-5 Transit Precautions

To safeguard the instrument against transportation damage, it is recommended to keep the instrument in its factory container until ready for installation.

## 5-6 Removal from Storage

Upon removal of the instrument from storage, a visual inspection should be conducted to verify its "as-received" condition. If the instrument has been subject to storage conditions in excess of those recommended (See Section 4-3), it should be subjected to a pneumatic pressure test in accordance with applicable vessel codes.

**LIMITED WARRANTY**

Seller warrants that the Goods manufactured by Seller will be free from defects in materials or workmanship under normal use and service and that the Software will execute the programming instructions provided by Seller until the expiration of the earlier of twelve (12) months from the date of initial installation or eighteen (18) months from the date of shipment by Seller. Products purchased by Seller from a third party for resale to Buyer ("Resale Products") shall carry only the warranty extended by the original manufacturer.

All replacements or repairs necessitated by inadequate preventive maintenance, or by normal wear and usage, or by fault of Buyer, or by unsuitable power sources or by attack or deterioration under unsuitable environmental conditions, or by abuse, accident, alteration, misuse, improper installation, modification, repair, storage or handling, or any other cause not the fault of Seller are not covered by this limited warranty, and shall be at Buyer's expense.

Goods repaired and parts replaced during the warranty period shall be in warranty for the remainder of the original warranty period or ninety (90) days, whichever is longer. This limited warranty is the only warranty made by Seller and can be amended only in a writing signed by an authorized representative of Seller.

**BROOKS SERVICE AND SUPPORT**

Brooks is committed to assuring all of our customers receive the ideal flow solution for their application, along with outstanding service and support to back it up. We operate first class repair facilities located around the world to provide rapid response and support. Each location utilizes primary standard calibration equipment to ensure accuracy and reliability for repairs and recalibration. The primary standard calibration equipment to calibrate our flow products is certified by our local Weights and Measures Authorities and traceable to the relevant International Standards.

Visit [www.BrooksInstrument.com](http://www.BrooksInstrument.com) to locate the service location nearest to you.

**START-UP SERVICE AND IN-SITU CALIBRATION**

Brooks Instrument can provide start-up service prior to operation when required.

For some process applications, where ISO-9001 Quality Certification is important, it is mandatory to verify and/or (re)calibrate the products periodically. In many cases this service can be provided under in-situ conditions, and the results will be traceable to the relevant international quality standards.

**CUSTOMER SEMINARS AND TRAINING**

Brooks Instrument can provide customer seminars and dedicated training to engineers, end users and maintenance persons. Please contact your nearest sales representative for more details.

**HELP DESK**

In case you need technical assistance:

- Americas ☎ 1-888-554-FLOW
- Europe ☎ +(31) 318 549 290 Within Netherlands ☎ 0318 549 290
- Asia ☎ +011-81-3-5633-7100



Due to Brooks Instrument's commitment to continuous improvement of our products, all specifications are subject to change without notice.

**TRADEMARKS**

- Brooks .....Brooks Instrument, LLC
- Buna .....DuPont Dow Elastomers
- Kalrez ..... DuPont Dow Elastomers
- Teflon ..... E.I. DuPont de Nemours & Co.
- Viton ..... DuPont Performance Elastomers

**Brooks Instrument**  
 407 West Vine Street  
 P.O. Box 903  
 Hatfield, PA 19440-0903 USA  
 T (215) 362-3700  
 F (215) 362-3745  
 E-Mail [BrooksAm@BrooksInstrument.com](mailto:BrooksAm@BrooksInstrument.com)  
[www.BrooksInstrument.com](http://www.BrooksInstrument.com)

**Brooks Instrument**  
 Neonstraat 3  
 6718 WX Ede, Netherlands  
 T 31-318-549-300  
 F 31-318-549-309  
 E-Mail [BrooksEu@BrooksInstrument.com](mailto:BrooksEu@BrooksInstrument.com)

**Brooks Instrument**  
 1-4-4 Kitasuna Koto-Ku  
 Tokyo, 136-0073 Japan  
 T 011-81-3-5633-7100  
 F 011-81-3-5633-7101  
 E-Mail [BrooksAs@BrooksInstrument.com](mailto:BrooksAs@BrooksInstrument.com)