

Installation and Operation Manual

X-CM-QmB-eng

Part Number: 541B029AAG

June, 2011

Brooks® Quantim Low Flow Coriolis Precision Mass Flow Measurement and Control



"Quantim Coriolis mass flow controllers enable precision measurement and control with maximum flexibility and lowest overall cost of ownership."

QmB Series IP40, IP66, IP66XP

Essential Instructions

Read before proceeding!

Brooks Instrument designs, manufactures and tests its products to meet many national and international standards. These products must be properly installed, operated and maintained to ensure they continue to operate within their normal specifications. The following instructions must be adhered to and integrated into your safety program when installing, operating and maintaining Brooks Instrument products.

- To ensure proper performance, use qualified personnel to install, operate, update, program and maintain the product.
- Read all instructions prior to installing, operating and servicing the product. If this instruction manual is not the correct manual, please see back cover for local sales office contact information. Save this instruction manual for future reference.

▲ WARNING: Do not operate this instrument in excess of the specifications listed in the Instruction and Operation Manual. Failure to heed this warning can result in serious personal injury and / or damage to the equipment.

- If you do not understand any of the instructions, contact your Brooks Instrument representative for clarification.
- Follow all warnings, cautions and instructions marked on and supplied with the product.
- Install your equipment as specified in the installation instructions of the appropriate instruction manual and per applicable local and national codes. Connect all products to the proper electrical and pressure sources.
- Operation: (1) Slowly initiate flow into the system. Open process valves slowly to avoid flow surges. (2) Check for leaks around the flow meter inlet and outlet connections. If no leaks are present, bring the system up to the operating pressure.
- Please make sure that the process line pressure is removed prior to service. When replacement parts are required, ensure that qualified people use replacement parts specified by Brooks Instrument. Unauthorized parts and procedures can affect the product's performance and place the safe operation of your process at risk. Look-alike substitutions may result in fire, electrical hazards or improper operation.
- Ensure that all equipment doors are closed and protective covers are in place to prevent electrical shock and personal injury, except when maintenance is being performed by qualified persons.

▲ WARNING: For liquid flow devices, if the inlet and outlet valves adjacent to the devices are to be closed for any reason, the devices must be completely drained. Failure to do so may result in thermal expansion of the liquid that can rupture the device and may cause personal injury.

European Pressure Equipment Directive (PED)

All pressure equipment with an internal pressure greater than 0.5 bar (g) and a size larger than 25mm or 1" (inch) falls under the Pressure Equipment Directive (PED).

- The Specifications Section of this manual contains instructions related to the PED directive.
- Meters described in this manual are in compliance with EN directive 97/23/EC.
- All Brooks Instrument Flowmeters fall under fluid group 1.
- Meters larger than 25mm or 1" (inch) are in compliance with PED category I, II or III.
- Meters of 25mm or 1" (inch) or smaller are Sound Engineering Practice (SEP).

European Electromagnetic Compatibility (EMC)

The Brooks Instrument (electric/electronic) equipment bearing the CE mark has been successfully tested to the regulations of the Electro Magnetic Compatibility (2004/108/EC (EMC directive 89/336/EEC)).

Special attention however is required when selecting the signal cable to be used with CE marked equipment.

Quality of the signal cable, cable glands and connectors:

Brooks Instrument supplies high quality cable(s) which meets the specifications for CE certification.

If you provide your own signal cable you should use a cable which is overall completely screened with a 100% shield.

"D" or "Circular" type connectors used should be shielded with a metal shield. If applicable, metal cable glands must be used providing cable screen clamping.

The cable screen should be connected to the metal shell or gland and shielded at both ends over 360 Degrees.

The shield should be terminated to an earth ground.

Card Edge Connectors are standard non-metallic. The cables used must be screened with 100% shield to comply with CE certification.

The shield should be terminated to an earth ground.

For pin configuration : Please refer to the enclosed Instruction Manual.

ESD (Electrostatic Discharge)

▲ CAUTION: This instrument contains electronic components that are susceptible to damage by static electricity. Proper handling procedures must be observed during the removal, installation or other handling of internal circuit boards or devices.

Handling Procedure:

1. Power to unit must be removed.
2. Personnel must be grounded, via a wrist strap or other safe, suitable means before any printed circuit card or other internal device is installed, removed or adjusted.
3. Printed circuit cards must be transported in a conductive container. Boards must not be removed from protective enclosure until immediately before installation. Removed boards must immediately be placed in protective container for transport, storage or return to factory.

Comments

This instrument is not unique in its content of ESD (electrostatic discharge) sensitive components. Most modern electronic designs contain components that utilize metal oxide technology (NMOS, SMOS, etc.). Experience has proven that even small amounts of static electricity can damage or destroy these devices. Damaged components, even though they appear to function properly, exhibit early failure.

Installation and Operation Manual

X-CM-QmB-eng

Part Number: 541B029AAG

June, 2011

QmB Series IP40, IP66, IP66XP

Dear Customer,

We appreciate this opportunity to service your flow measurement and control requirements with a Brooks Instrument device. Every day, flow customers all over the world turn to Brooks products for solutions to their gas and liquid low-flow applications. Brooks provides an array of flow measurement and control products for various industries from biopharmaceuticals, oil and gas, fuel cell research and chemicals, to medical devices, analytical instrumentation, semiconductor manufacturing, and more.

The Brooks product you have just received is of the highest quality available, offering superior performance, reliability and value to the user. It is designed with the ever changing process conditions, accuracy requirements and hostile process environments in mind to provide you with a lifetime of dependable service.

We recommend that you read this manual in its entirety. Should you require any additional information concerning Brooks products and services, please contact your local Brooks Sales and Service Office listed on the back cover of this manual or visit www.BrooksInstrument.com

Yours sincerely,

Brooks Instrument

QmB Series IP40, IP66, IP66XP

Quick Start Instructions IP40 - For Liquid Service

Horizontal Mounting

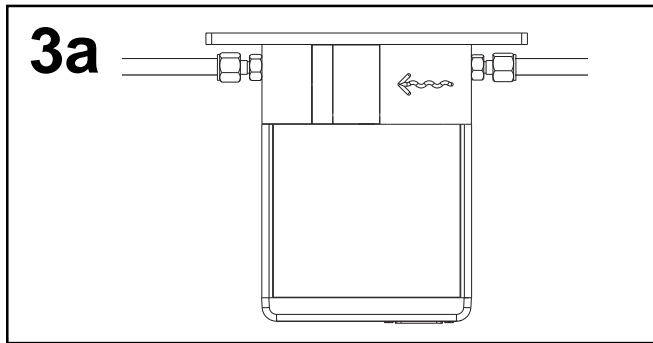
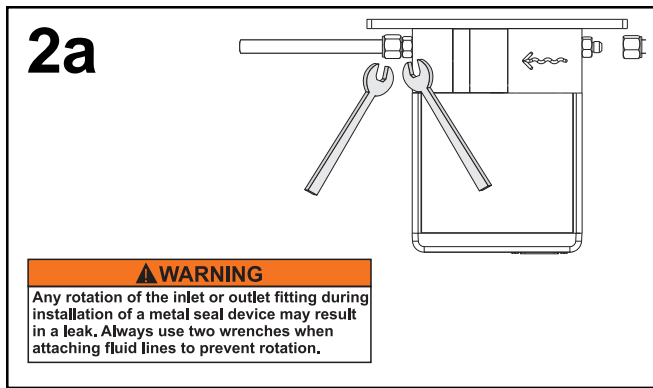
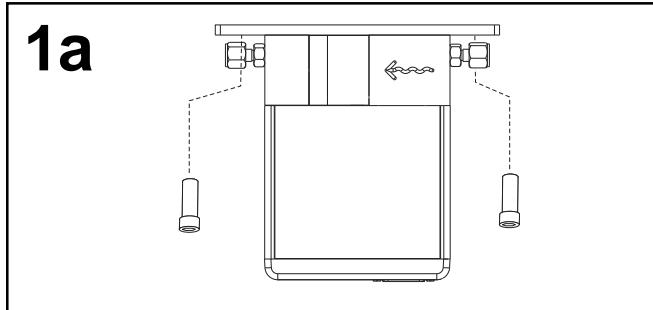

D-CONNECTOR PINOUTS

PIN #	FUNCTION	Controller	Meter
1	Setpoint Common	•	N/A
2	0-5 Vdc Flow Signal Output	•	•
3	Alarm Output	•	•
4	* 4-20 mA Flow Signal Output	•	•
5	+14 Vdc to 27 Vdc Power Supply	•	•
6	Not Used		
7	* 4-20 mA Setpoint Input (+)	•	N/A
8	0-5 Vdc Setpoint Input (+)	•	N/A
9	Power Supply Common	•	•
10	Signal Output Common	•	•
11	+5 Volt Reference Output		
12	Valve Override Input	•	N/A
13	* 4-20 mA or 0-5 Vdc Density or Temp.	•	•
14	Not Used		
15	Not Used		

* DO NOT APPLY POWER TO THESE PINS

Vertical Mounting

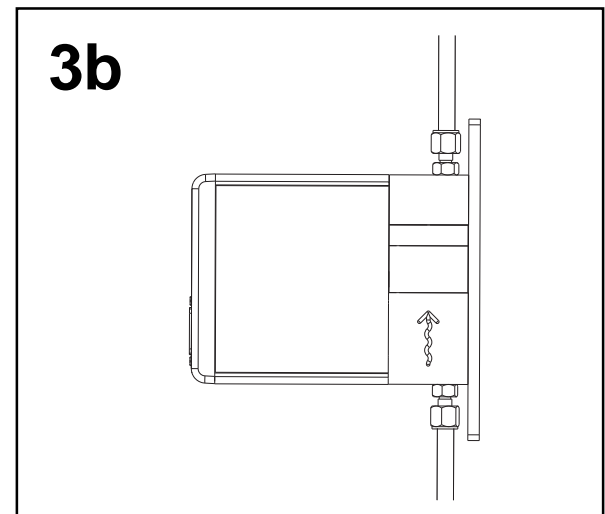
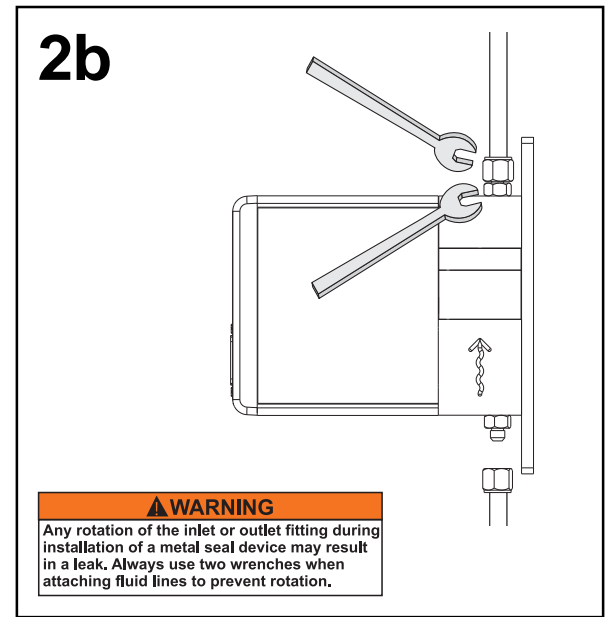
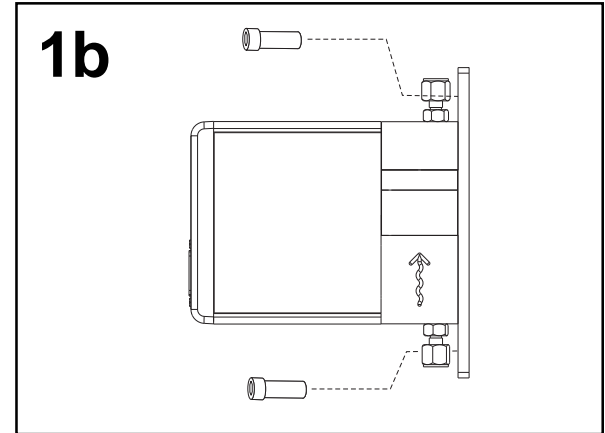

Installation and Operation Manual

X-CM-QmB-eng

Part Number: 541B029AAG

June, 2011

QmB Series IP40, IP66, IP66XP

Quick Start Instructions IP40 - For Gas Service

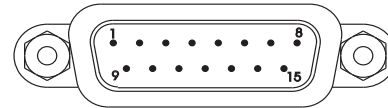
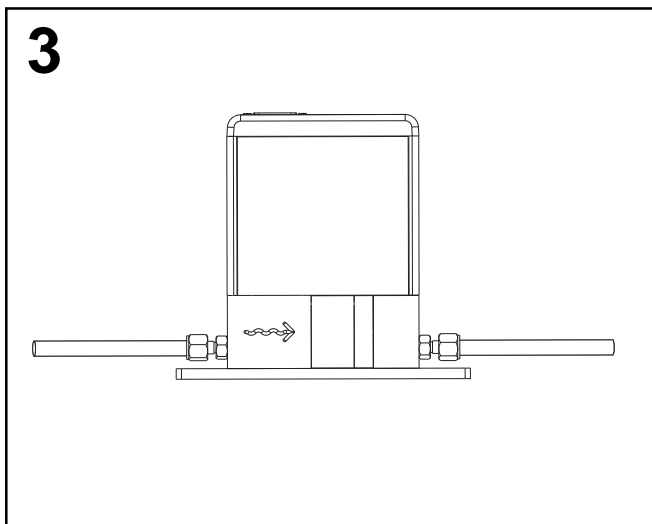
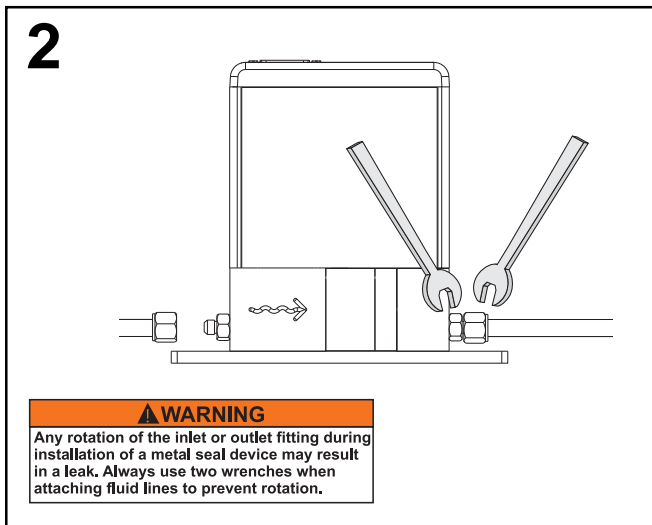
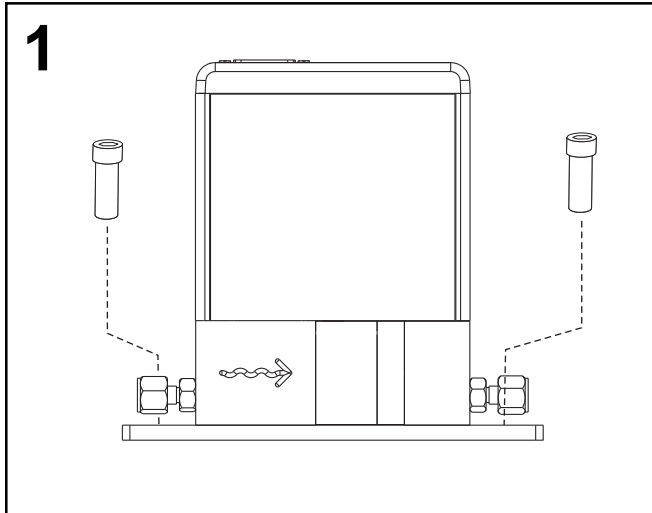

D-CONNECTOR PINOUTS

PIN #	FUNCTION	Controller	Meter
1	Setpoint Common	•	N/A
2	0-5 Vdc Flow Signal Output	•	•
3	Alarm Output		
4	* 4-20 mA Flow Signal Output	•	•
5	+14 Vdc to 27 Vdc Power Supply	•	•
6	Not Used		
7	* 4-20 mA Setpoint Input (+)	•	N/A
8	0-5 Vdc Setpoint Input (+)	•	N/A
9	Power Supply Common	•	•
10	Signal Output Common	•	•
11	+5 Volt Reference Output		
12	Valve Override Input	•	N/A
13	* 4-20 mA or 0-5 Vdc Density or Temp.	•	•
14	Not Used		
15	Not Used		

* DO NOT APPLY POWER TO THESE PINS

⚠ CAUTION

- Incorrect voltage will cause flowmeter damage or failure.
- Quantim is an input sinking device. Do not use a current sinking PLC output card.
- Quantim sources its own 4-20mA output signal. Do not source this output with an external supply.

⚠ WARNING

Operating Procedure: Do not operate this instrument outside the specifications listed in Section 1 of this manual. Before bringing the unit into operation, make sure all fluid connections have been correctly tightened and that all electrical connections have been made.

⚠ WARNING

When used with a reactive (sometimes toxic) chemical, contamination or corrosion may occur as a result of plumbing leaks or improper purging. Plumbing should be checked carefully for leaks.

QmB Series IP40, IP66, IP66XP

Quick Start Instructions IP66

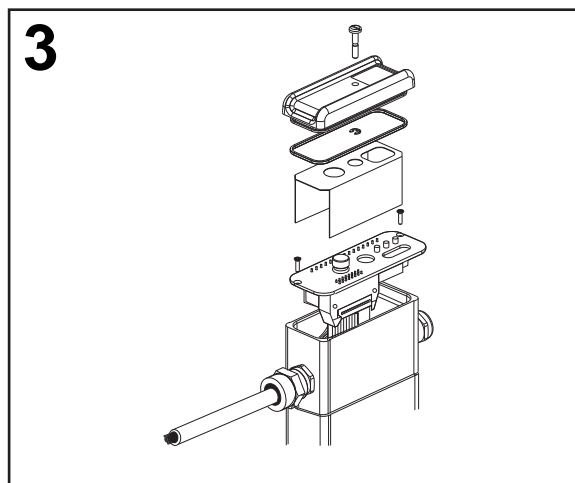
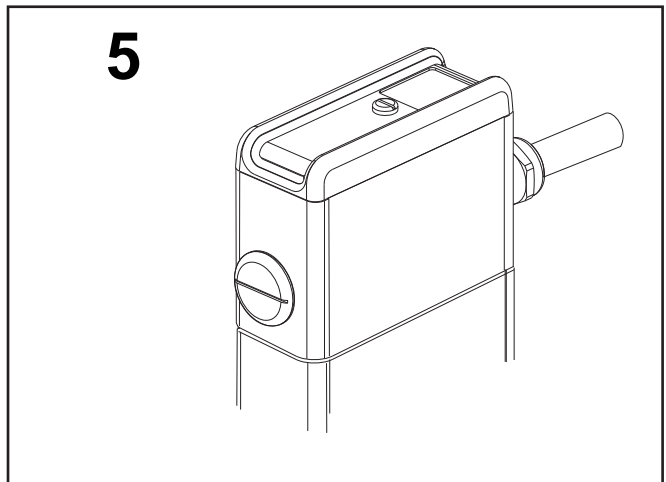
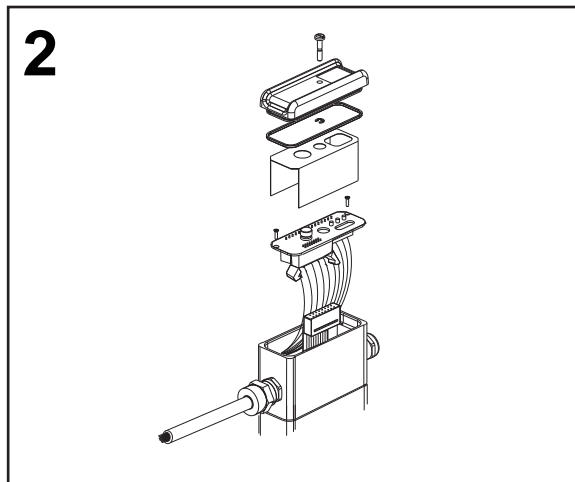
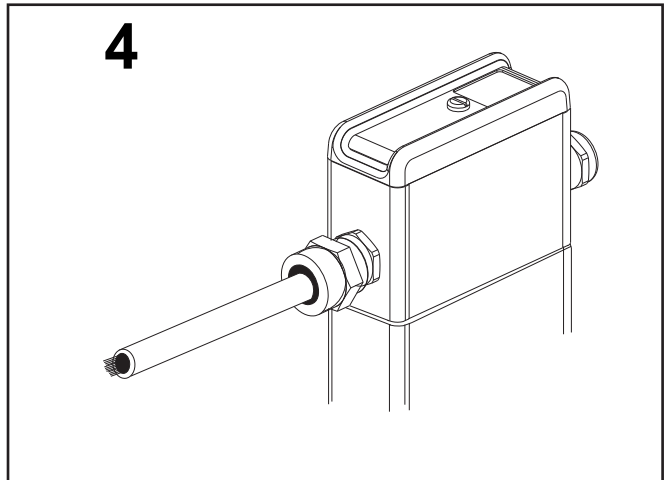
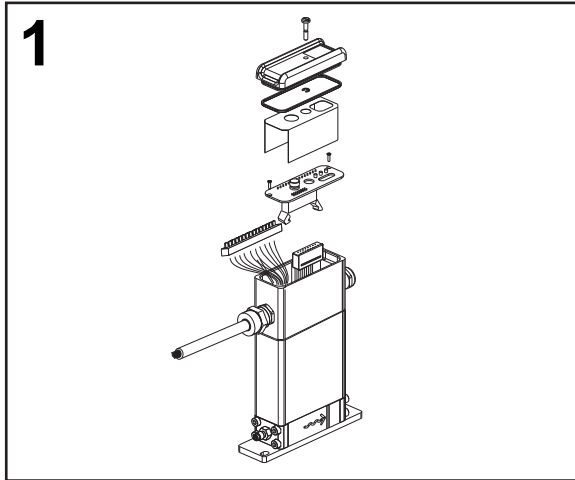

FIELD WIRING CONNECTIONS

1	CMD.	<p>LOCATE AND DETACH CONNECTORS AS SHOWN</p> <p>③</p> <p>④</p>
	FLOW	
	COM.	
15		

① REMOVE SCREWS

② LIFT KNOB TO ACCESS CONNECTIONS

***DO NOT APPLY POWER TO THESE PINS**

Installation and Operation Manual

X-CM-QmB-eng

Part Number: 541B029AAG

June, 2011

QmB Series IP40, IP66, IP66XP

Quick Start Instructions IP66XP

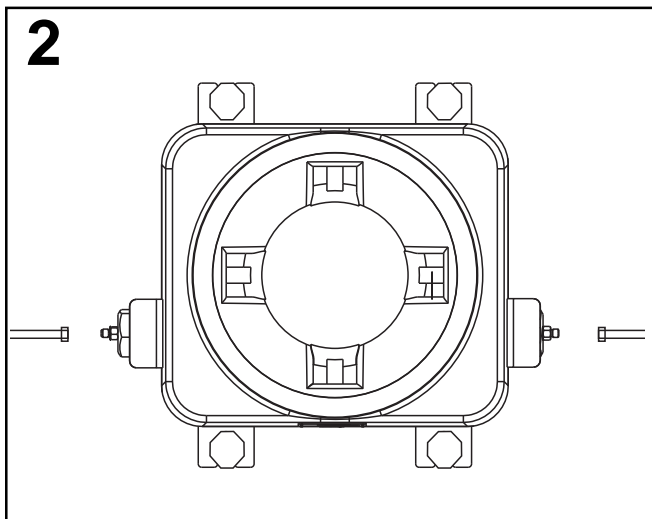
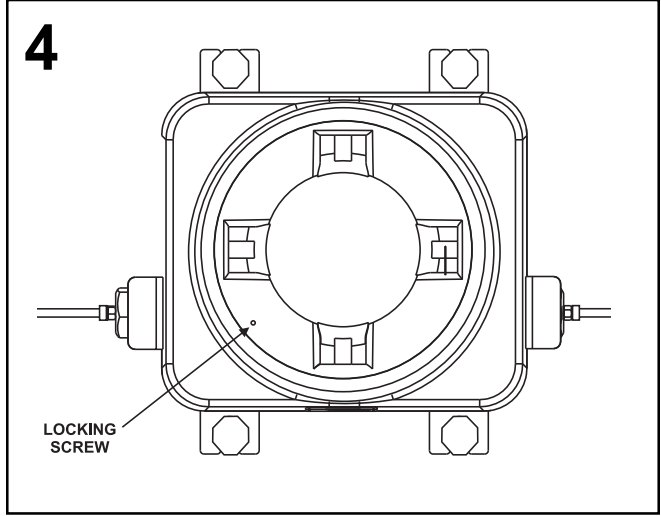
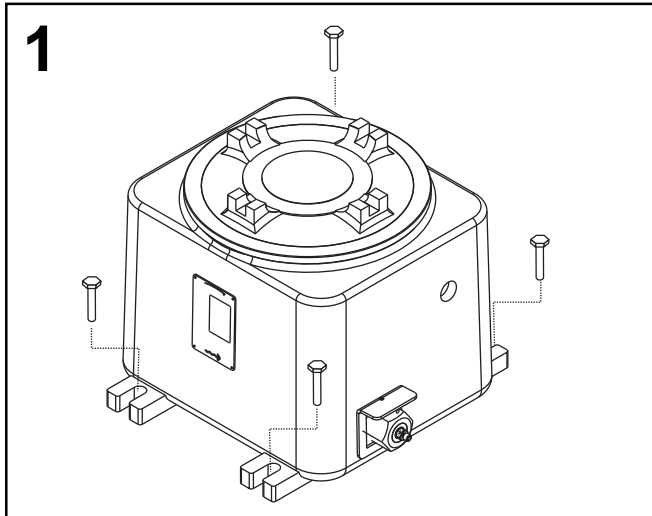

D-CONNECTOR PINOUTS

PIN #	FUNCTION	Controller	Meter
1	Setpoint Common	•	N/A
2	0-5 Vdc Flow Signal Output	•	•
3	Alarm Output	•	•
4	* 4-20 mA Flow Signal Output	•	•
5	+14 Vdc to 27 Vdc Power Supply	•	•
6	Not Used		
7	* 4-20 mA Setpoint Input (+)	•	N/A
8	0-5 Vdc Setpoint Input (+)	•	N/A
9	Power Supply Common	•	•
10	Signal Output Common	•	•
11	+5 Volt Reference Output	•	•
12	Valve Override Input	•	N/A
13	* 4-20 mA or 0-5 Vdc Density or Temp.	•	•
14	Not Used		
15	Not Used		

* DO NOT APPLY POWER TO THESE PINS

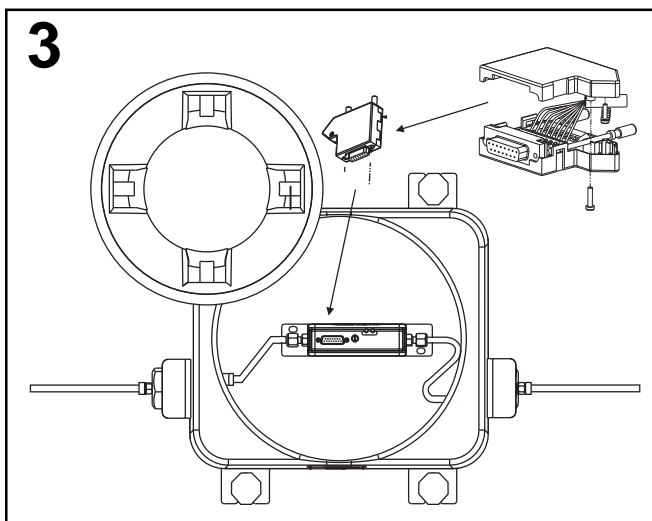

⚠ WARNING

Lifting hazard. Single person lift could cause injury. Use assistance.

Quick Start Instructions for Connecting HART® on 4-20 mA I/O

Refer to the X-Qm-HART Installation and Operation Manuals for complete wiring of a Brooks Quantim for HART interface. HART Communications is provided on the Primary Output of the Brooks Quantim device. Connecting a HART Communicator, or any HART modem, requires a connection between pins 4 and 1 as shown below. This connection can be anywhere on the current loop.

Proper wiring of a Brooks Quantim NEMA 1 / IP40

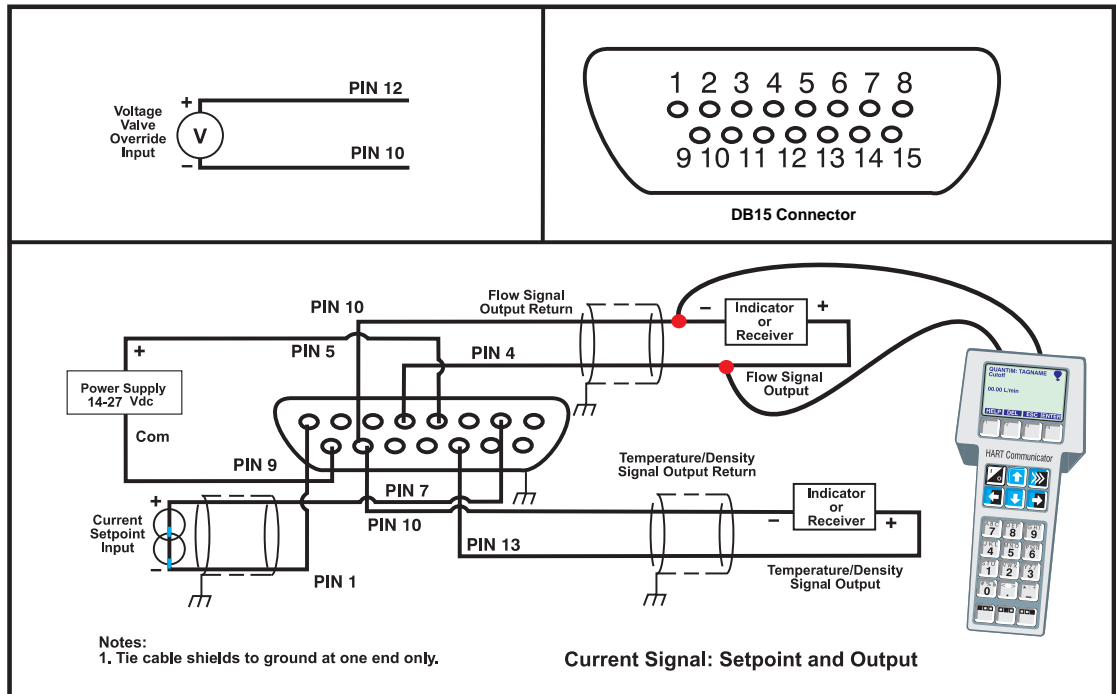

Proper wiring of a Brooks Quantim NEMA 4X / IP65

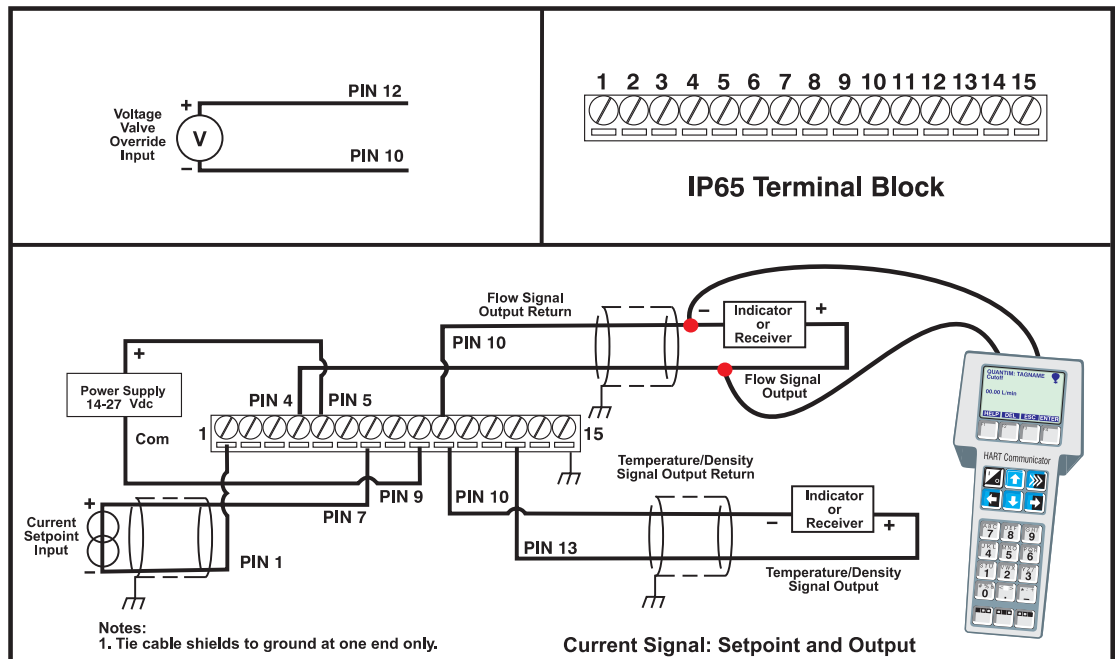

Installation and Operation Manual

X-CM-QmB-eng
 Part Number: 541B029AAG
 June, 2011

QmB Series IP40, IP66, IP66XP

Proper wiring of a Brooks Quantim Explosion Proof NEMA 4X / IP66XP

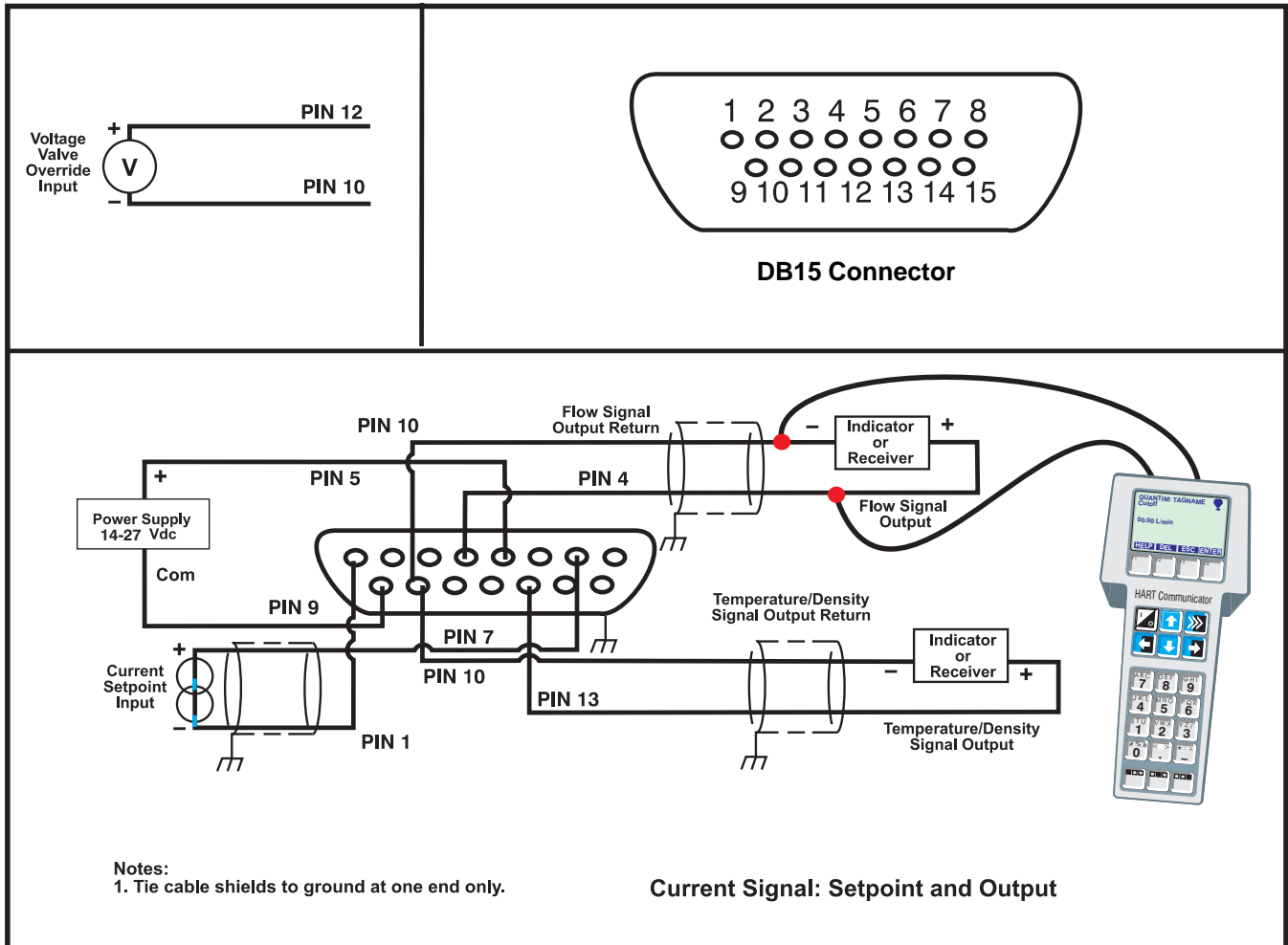

Quick Start Instructions for Connecting Alarm Output

Alarm Output Option 1 - Relay

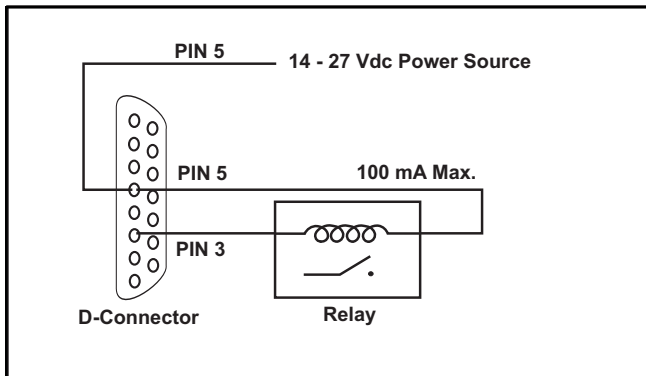

Alarm Output Option 2 - TTL

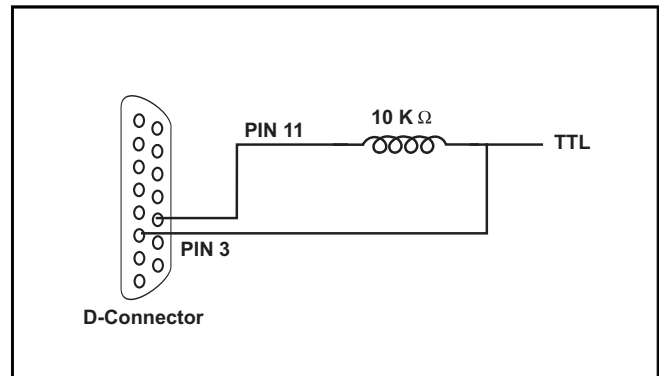

*THIS PAGE WAS
INTENTIONALLY
LEFT BLANK*

<u>Section Number</u>	<u>Page Number</u>
Quick Start Instructions	
Quick Start Instructions IP40 - For Liquid Service	QS-1
Quick Start Instructions IP40 - For Gas Service	QS-2
Quick Start Instructions IP66	QS-3
Quick Start Instructions IP66XP	QS-4
Quick Start Instructions for Connecting HART on 4-20 mAmp I/O	QS-5
Section 1 Introduction	
1-1 How to Use This Manual	1-1
1-2 Description	1-1
1-3 Performance Specifications	1-2
1-4 Dimensions	1-10
Section 2 Installation	
2-1 General	2-1
2-2 Receipt of Equipment	2-1
2-3 Recommended Storage Practice	2-1
2-4 Return Shipment	2-2
2-5 Transit Precautions	2-2
2-6 Fluid Connections	2-2
2-7 Mechanical Installation	2-3
2-8 Process Mounting	2-4
2-9 Electrical Interfacing	2-6
2-10 Interconnection with Peripheral Equipment	2-9
Section 3 Operation	
3-1 Operating Procedure	3-1
3-2 Zero Adjustment	3-2
3-3 Calibration Procedure	3-4
Section 4 Maintenance	
4-1 General	4-1
4-2 Troubleshooting	4-2
4-3 External Valve Service	4-7
Section A Essential Instructions	
A-1 Essential Instructions	A-1
Warranty, Local Sales/Service Contact Information	Back Cover

QmB Series IP40, IP66, IP66XP

Figures

<u>Figure Number</u>	<u>Page Number</u>
1-1 Dimension Drawing QmB IP40 Downported	1-10
1-2 Dimension Drawing QmB IP40	1-11
1-3 D-Connector Electrical Pin Connections	1-11
1-4 Lay-In Dimensions Integral and Remote Valves	1-11
1-5 Dimensional Drawing QmB IP40 with Remote Valve	1-12
1-6 Dimensional Drawing QmB IP66	1-12
1-7 Dimensional Drawing QmB IP66XP	1-13
2-1 Flow Direction Through the Quantim, as Indicated by the Arrow Engraved on the Meter/Controller Body	2-4
2-2 Horizontal Inverted Installation	2-5
2-3 Horizontal Right Side Up Installation	2-5
2-4 Vertical Flow Up Installation	2-6
2-5 Proper Wiring of a Brooks QmB IP66XP NEMA 4X	2-8
2-6 Alarm Output Wiring Options	2-8
2-7 Wire Color Codes for 'D' Connector Assembly	2-10
3-1 Location of LEDs	3-1
3-2 Location of the Zero Button	3-2
4-1 Bench Troubleshooting Circuit	4-6
4-2 Parts List	4-8
4-3 Exploded Diagram of Valve Assembly	4-9
4-4 Valve Torque Pattern	4-9

Tables

<u>Table Number</u>	<u>Page Number</u>
2-1 Electrical Interfacing for Quantim	2-8
4-1 Troubleshooting	4-3

1-1 How to Use This Manual

It is recommended to read this manual before installing, operating or troubleshooting your Quantim® Mass Flow Meter/Controller.

This manual is organized into the following sections:

Section 1.	Introduction
Section 2.	Installation
Section 3.	Operation
Section 4.	Maintenance
Section 5.	Specifications and Approvals
Sections A-B	Appendices
Back Cover	Warranty, Local Sales/Service Contact Information

The Quality System at Brooks Instrument conforms to the quality standards set forth in ISO 9001.

This instruction manual is intended to provide the user with all the information necessary to install, operate and maintain the Brooks Quantim Mass Flow Meters and Controllers.

1-2 Description

Brooks Quantim Mass Flow Meters are used to provide accurate measurements of fluid flow, fluid density and temperature. The heart of these systems is the Coriolis mass flow sensor, which produces an electrical output signal directly proportional to mass flow rate and density. Brooks Quantim Mass Flow Controllers couple the Coriolis sensor with a control valve. Dependant on the application, this can be fully integrated within the product or remote but close-coupled. The Brooks Quantim additionally possesses digital signal processing (DSP) electronics and PID control electronics to provide measurement and control in one complete package.

The Quantim device is available for a wide range of gas and liquid flows. (See specifications, Section 1-3 for details).

QmB Series IP40, IP66, IP66XP

1-3 Performance Specifications

Performance Specifications:

Flow:

Liquid Flow Specifications, Metric Units⁽⁹⁾

Product Type	Quantim Model ⁽¹⁾	Quantim Tube Size	Maximum Flow Rate ⁽²⁾	Nominal Flow Rate ⁽²⁾	Minimum Full Scale	Minimum Measurable Flow
			Kg/hr or l/hr	Kg/hr or l/hr		
Controller	QMBC	2	0.30	0.15	0.01	0.001
		3	1.00	0.78	0.10	0.010
		4	15.94	7.97	1.00	0.100
Meter	QMBM	2	0.38	0.19	0.01	0.001
		3	1.00	1.00	0.10	0.010
		4	27.00	13.50	1.00	0.100

Liquid Flow Specifications, English Units⁽⁹⁾

Product Type	Quantim Model ⁽¹⁾	Quantim Tube Size	Maximum Flow Rate ⁽²⁾		Nominal Flow rate ⁽²⁾		Minimum Measurable Flow
			lb/hr	gal/hr	lb/hr	gal/hr	
Controller	QMBC	2	0.66	0.08	0.33	0.04	0.002
		3	2.21	0.26	1.72	0.21	0.022
		4	35.15	4.21	17.57	2.11	0.221
Meter	QMBM	2	0.84	0.10	0.42	0.05	0.002
		3	2.21	0.26	2.21	0.26	0.022
		4	59.54	7.13	29.77	3.57	0.221

Gas Flow Specifications

Flow rates that produce approximately 14.5 psig (1bar) pressure drop on air at 70°F (21°C) with an inlet pressure of 500 psi (35 bar)

Product Type	Quantim Model ⁽¹⁾	Quantim Tube Size	Nominal Mass Flow Rate		Nominal Volume Flow Rate		
			lb/hr	Kg/hr	scfh ⁽³⁾	sccm ⁽³⁾	ml/min ⁽⁵⁾
Controller	QMBC	2	0.168	0.076	2.227	1051	975.2
		3	0.472	0.214	6.261	2955	2743
		4	3.960	1.796	52.52	24787	23009
Meter	QMBM	2	0.227	0.103	3.034	1432	1329
		3	0.893	0.405	11.86	5595	5193
		4	8.476	3.840	112.6	53116	49319

Gas Flow Limits

Air, 70°F (21°C), 14.5 psi (1 bar) pressure drop

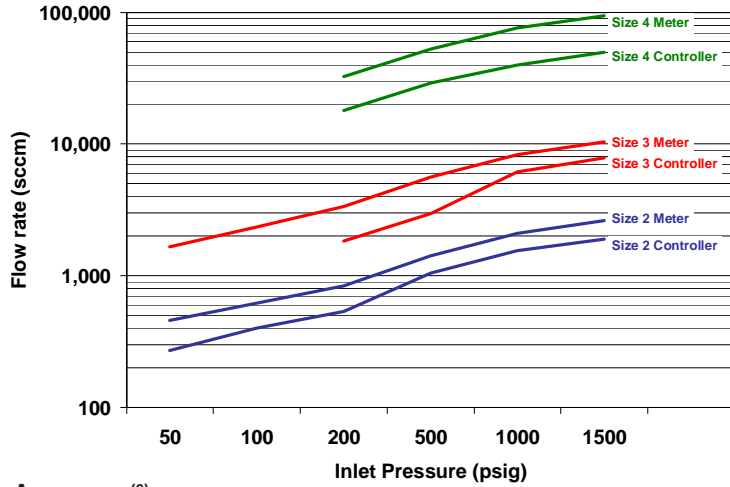

Accuracy⁽⁶⁾

± measurement accuracy % of rate or [(zero stability/flowrate) x 100] % of rate, which ever is greater

Measurement Accuracy

Sensor Tube Material	Fluid Type	Standard Flow Measurement Accuracy (% of rate)	Optional Flow Measurement Accuracy (% of rate)
Stainless Steel	Liquid	0.2%	0.5%
	Gas	0.5%	1.0%
Hastelloy	Liquid	0.5%	1.0%
	Gas	0.5%	1.0%

Zero Stabilities

Sensor Tube Material	Tube Size	Zero Stability (Kg/hr)	Zero Stability (Lb/hr)
Stainless Steel	2	0.00013	0.0003
	3	0.0010	0.0022
	4	0.0040	0.0088
Hastelloy	2	0.0002	0.0004
	3	0.0015	0.0033
	4	0.0120	0.0265

Standard Measurement Accuracy vs Flow Rate Chart, Tube Size 2

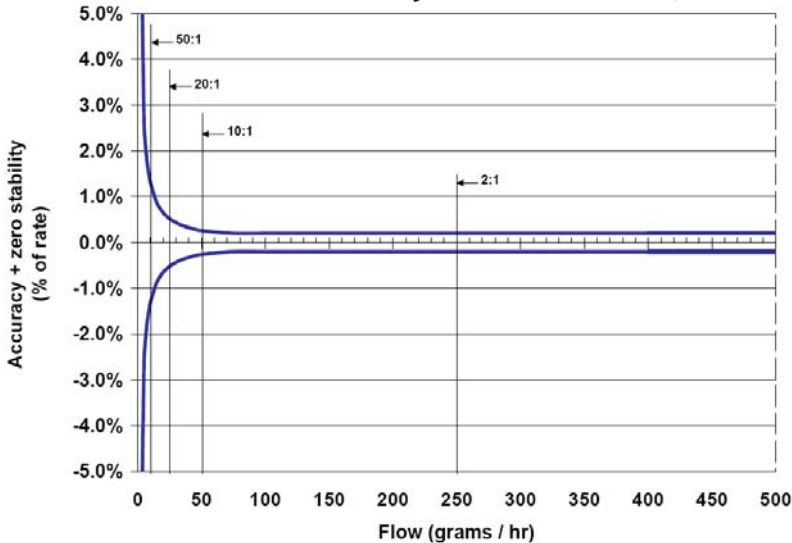

QmB Series IP40, IP66, IP66XP

Repeatability⁽⁷⁾:

± 0.05% or ± [0.5 x (zero stability/flowrate) x 100]% of rate whichever is greater

Device Leak Integrity⁽⁸⁾:

Elastomer Sealed Device: Outboard 1 x 10⁻⁹ atm. cc/sec., helium (maximum)
 Metal Sealed Device: 1 x 10⁻¹⁰ atm. cc/sec., helium (maximum)

Turn Down:

Controller: 100:1 or down to the minimum measurable flow, whichever flow rate is greater
 Meter: to minimum measurable flow

Settling Time:

Controller (Stainless Steel sensor tube): Less than 2 seconds within 2 % full scale of final value, ± [(zero stability/flowrate) x 100]% of rate per SEMI Guideline E17-91
 Controller (Hastelloy sensor tube): Less than 12 seconds within 2 % full scale of final value per SEMI Guideline E17-91
 Meter: Less than 0.5 seconds within 2 % full scale of final value, ± [(zero stability/flowrate) x 100]% of rate per SEMI Guideline E17-91

Maximum Operating Pressure⁽⁸⁾:

Standard: 3.5 MPa, 35 bar or 500 psi
 Optional: 10 MPa, 100 bar or 1500 psi
 Optional: 30 MPa, 300 bar or 4500 psi (Hastelloy sensor tube only)

Differential Pressure Requirements, Controller⁽⁹⁾:

		Liquid						Gas					
Quantim	Quantim	KpA		bar		psi		KpA		bar		psi	
Model ⁽¹⁾	Tube Size	min	max*	min	max*	min	max*	min	max*	min	max*	min	max*
QMBC	2	69	1034	0.7	10.3	10	150	69	1724	0.7	17.2	10	250
	3	69	1379	0.7	13.8	10	200	69	1034	0.7	10.3	10	150
	4	69	1379	0.7	13.8	10	200	69	1034	0.7	10.3	10	150

* Actual maximum pressure drop will depend on process conditions and orifice selection.

Differential Pressures, Meter⁽⁹⁾

Pressure Drop Liquid - (H₂O)

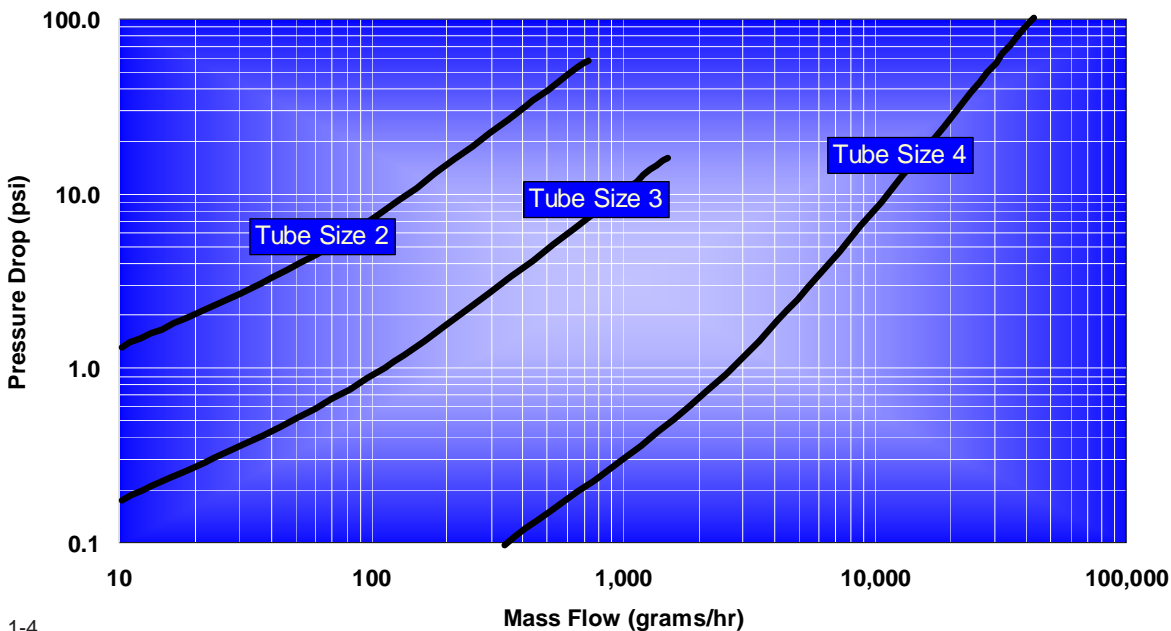

Pressure Drop Air @ 500 psi Inlet Pressure

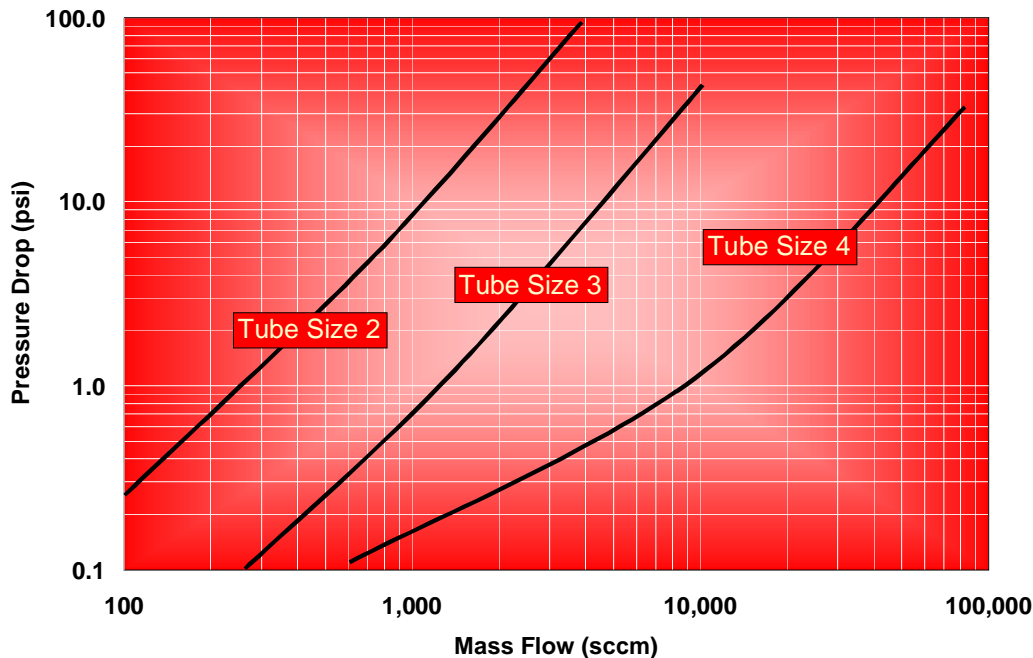

Density⁽¹⁰⁾:

Range:	0.2 to 2.0 grams/cc
Accuracy:	±0.005 grams/cc
Repeatability:	±0.002 grams/cc

Temperature⁽¹¹⁾

Device Temperature Range:	0 to 65°C or 32 to 149°F
Accuracy:	± 0.5°C or ± 1.0°F

Notes

- (1) QMBC - Brooks Quantim controller with integral control valve. QMBM - Brooks Quantim meter (no valve).
- (2) The nominal flow rate is the flow rate at which water at reference conditions causes approximately 1 bar of pressure drop or the laminar to turbulent transition flow whichever is lower. Maximum flow rate is twice nominal flow rate or the laminar to turbulent transition flow whichever is lower.
- (3) Standard volumetric conditions are 14.696 psia and 70°F.
- (4) Actual volumetric flow is a function of the mass flow and density measurements; Therefore, the accuracy of the actual volumetric flow is a function of the mass flow and density accuracy.
- (5) ml_n/min Reference Conditions 0°C at 1013.25 mbar.
- (6) Accuracy includes combined repeatability, linearity, and hysteresis. Specifications are based on reference test conditions of water/nitrogen at 68 to 77°F (20 to 25°C) and 15 to 30 psig (1 to 2 bar).
- (7) Repeatability- The maximum difference between output readings when the same input is applied consecutively; the closeness of agreement among consecutive measurements of an output for the same value of input under the same operating conditions, approaching from the same direction.
- (8) Helium leak and pressure test of elastomer sealed devices is performed with integral 5/16" -24 UNF connection.
- (9) Differential pressures are based on reference conditions of water and air at 68 to 77°F (20 to 25°C).
- (10) For applications with fluid density in the range from 0.3 to 0.5 grams/cc the device may be sensitive to 50Hz or 60Hz vibration. The density measurement at temperatures other than 21° C (70° F) has an additional error of approximately 0.0005 grams/cc per deg C. The density output signal is available below 0.2grams/sec. The density accuracy is applicable over the stated density range.

QmB Series IP40, IP66, IP66XP

Physical Specifications

⚠ CAUTION

It is the user's responsibility to select and approve all materials of construction. Careful attention to metallurgy, engineered materials and elastomeric materials is critical to safe operation.

Materials of Construction:

Process Wetted: 316L, 316L VAR, High Alloy Ferritic Stainless and 17-7PH

Optional: Hastelloy sensor tube.

Process Seals:

Elastomer Seal: Viton® fluoroelastomers, Buna, Kalrez® or EPDM

Metal Seal: Stainless Steel and Nickel

Housing:

IP40: Polyurethane painted Aluminum

IP66: Polyurethane painted Aluminum

IP66XP: Aluminum

Inlet Filter:

Tube Size 2 Controller: 1 micron or 10 micron inlet filter recommended

Tube Size 3 or 4: 10, 20, 30 & 40 micron filters available

Weight:

Housing: IP40: 1.6 kg or 3.5 Lbs.

Housing: IP66: 1.9 kg or 4.2 Lbs.

Housing: IP66XP: 24 kg or 52 Lbs.

Moisture Content:

Purged to exhaust dew point less than -40°C (-40°F) prior to shipment to remove calibration liquid, to prevent process contamination.

Then vacuum bagged at ambient room conditions.

Process Fitting Options:

1/16", 1/8", 1/4" or 6mm tube compression, VCR, VCO or NPT(F), 3.2 mm UPG, Down Port ANSI/ISA 76.00.02 (See Model Code).

Electrical Connections:

IP40: 15 pin D-Type connector. (See Figure 3).

IP66: Unpluggable Terminal Block 28-16 Awg.

IP66XP: ¾" NPT wiring access to IP40 Device with 15 pin D-Type connector.

Dimensions:

See Figures 1-1 through 1-7

Functional Specifications**Output Signals⁽¹³⁾:**

- 4-20 mA or 0-5 Vdc active outputs represent mass flow or volume flow⁽⁴⁾.
- And simultaneously available 4-20 mA or 0-5 Vdc active output, represents on-line density or temperature information.
- Alarm output, max. voltage 30 Vdc, max. current 100 mA

Input Signals⁽¹³⁾:

- Command (setpoint) that drives the control valve, either 4-20 mA or 0-5 Vdc input signals.
- Valve Override Function:
 - Left floating/unconnected - instrument controls flow at setpoint
 - Connected to signal at or above 5.0 Volts - valve is forced open
 - Connected to signal at or below 0.0 Volts - valve is forced closed

Signal Specifications:	Pin 4	4-20 mA output	< 500 ohm series resistance
	Pin 2	0-5 Vdc output	> 1K ohm load
	Pin 13	4-20 mA output	< 500 ohm series resistance
		0-5 Vdc output	> 1K ohm load
	Pin 7	4-20 mA input	250 ohm input impedance
		0-5 Vdc input	200 ohm input impedance
	Pin 12	Valve override input	> 50K ohm input impedance
	Pin 3	Alarm output	100 mA maximum current sink

Power Requirements:

Voltage: +14 to 27 Vdc⁽¹²⁾.

Nominal Current: Controller: 300 mA to 400 mA
 Meter: 100 mA to 150 mA

Maximum Current: Controller: 715 mA @ 14 Vdc
 Meter: 470 mA @ 14 Vdc

Maximum Power: Controller: 10.0 W
 Meter: 6.6 W

Additional Functions and Outputs

Damping: Factory set time constant from 0 to 10 seconds.

Alarms and Warnings:

Alarms accessed via HART or the Brooks Service Tool can be configured to monitor the following variables⁽¹³⁾:

- Mass Flow
- Density
- Volumetric Flow
- Temperature
- Slug Flow
- Diagnostic Failure
- Setpoint Deviation
- Valve Drive

LED's⁽¹⁴⁾:

'STAT'
 solid green: system operative.
 solid red: system fault.
 'AL'
 flashing green: warning
 flashing red: alarm

Pushbutton⁽¹⁵⁾: 'ZERO' setting pushbutton.

Notes (continued)

⁽¹¹⁾ The device temperature is affected by the ambient and process temperature as well as internal warming when the device is powered. The device should be maintained in the specified temperature range at all times. A temperature rise of up to 20°C (68°F) from internal heating can occur in an open environment where ambient temperature is 23°C (73°F).

⁽¹²⁾ Ensure the minimum required voltage and current is available at the mass flow device taking into consideration any losses in the interconnecting cable.

⁽¹³⁾ If the Quantim is configured for HART® communication protocol, only 4-20 mA I/O option is available.

⁽¹⁴⁾ IP66 and IP66XP Series external housing cover must be removed to gain access to status LED's.

⁽¹⁵⁾ IP66XP series external housing cover must be removed to gain access to zero push button.

QmB Series IP40, IP66, IP66XP

Certifications and Approvals

IP40 Series



Non Incendive/ Non Sparking
United States and Canada- UL Recognized E73889, Vol. 3, Sect. 3.

Non Incendive , Class I, Division 2, Groups A, B, C and D; T4
Per UL 1604, UL 508 and CSA 22.2 No. 213 1987; C22.2 No. 14-M91

Ex nC IIC T4
Per CSA E79-15

Class I, Zone 2, AEx nC IIC T4
Per ANSI/UL 60079-15

Ambient Temperature: 0° C to 65° C

Enclosure: Type 1/ IP40

Europe - KEMA 04ATEX1241 X



II 3 G EEx nA II T4
Per EN 60079-15: 2003

Ambient Temperature: 0°C to 65°C

Enclosure: IP40

The modules shall be installed in a suitable enclosure providing a degree of at least IP54 according to EN60529, taking into account the environmental conditions under which the equipment will be used.

IP66 Series



Non Incendive/ Non Sparking
United States and Canada- UL Recognized E73889, Vol. 1, Sect. 26. (conduit entry)
United States and Canada Recognized, UL E73889, Vol. 3, Sect. 3. (cable gland entry)

Non Incendive , Class I, Division 2, Groups A, B, C and D;
Dust Ignition Proof, Class II, Division 2, Groups F and G; Suitable for Class III, Division 2; T4
Per UL 1604, UL 508 and CSA 22.2 N0. 213 1987; C22.2 No. 14-M91

Ex nC IIC T4
Per CSA E79-15

Class I, Zone 2, AEx nC IIC T4
Per ANSI/UL 60079-15

Ambient Temperature: 0° C to 65° C

Enclosure: Type 4X/ IP66

Certifications and Approvals

Europe - KEMA 05ATEX1068 X



II 3 G EEx nA II T4
II 3 D T 135 C
Per EN 60079-15: 2003, EN 50281-1-1: 1998 + A1

Ambient Temperature: 0° C to 65° C

Enclosure: IP66

IP66XP Series Explosion-proof/ Flame-proof

United States and Canada- UL Recognized E73889, Vol. 1, Sect. 21.



Explosion-proof , Class I, Division 1, Groups C and D;
Dust Ignition-proof, Class II, Division 1 Groups E, F, and G;
Suitable for Class III, Division 1; T4
Per ANSI/UL 1203 and CSA 22.2 No. 30

Ex nC IIC T4
Per CSA E79-1

Class I, Zone 2, AEx nC IIC T4
Per UL 60079-1

Ambient Temperature: 0° C to 65° C

Enclosure: Type 4X/ IP66

Europe - KEMA 05ATEX2052X



Ex d IIB T6 / Ex tD A21 IP66 T85° C, per EN 60079-0:2006, EN 60079-1:2007
EN 61241-0:2006 and EN 61241-1:2004

IECEx-KEM 09,0007X, Ex d IIB T6, Ex tD A21 IP66 T85° C, per IEC60079-0:2006,
EN 60079-1:2007, IEC 61241-1:2004, Ambient temperature 0° deg. C to +65° deg. C
(pending).

Ex d certified cable glands, blind plugs and conduit seals shall be used. A conduit seal shall be installed immediately at the enclosure wall. Use wiring/cables suitable for at least 80° deg. C

NOTE: Ex d slits on the breather drain valve acc. to IECEx TSA 07.0053 U

⚠ WARNING
Do not open when an explosive atmosphere may be present.

Environmental effects

EMC effects:

The Brooks Quantim series meets the requirements of the EMC directive 89/336EEC per EN 50081-2 and EN 61326-1. To meet these specifications, the Brooks Quantim device must be directly connected to a low impedance (less than 1 Ohm) earth ground. Signals must use a standard twisted-pair, shielded instrument wire.

Pressure effects:

The Brooks Quantim series meets the requirements of the Pressure Equipment Directive 97/23/EC. The unit falls into the category "Sound Equipment Practice".

QmB Series IP40, IP66, IP66XP

1-4 Dimensions

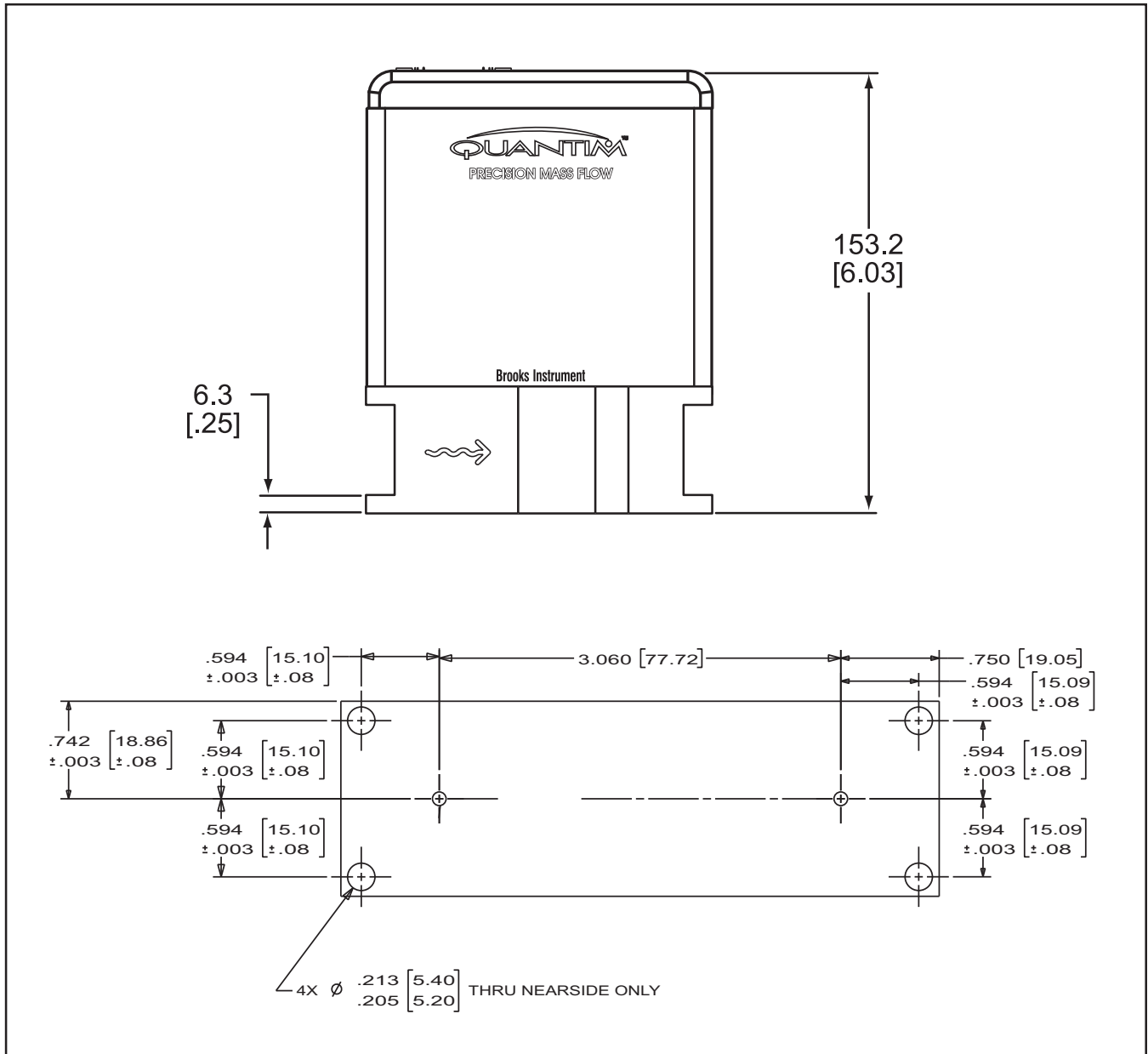

Figure 1-1 Dimensional Drawing QmB IP40 Downported

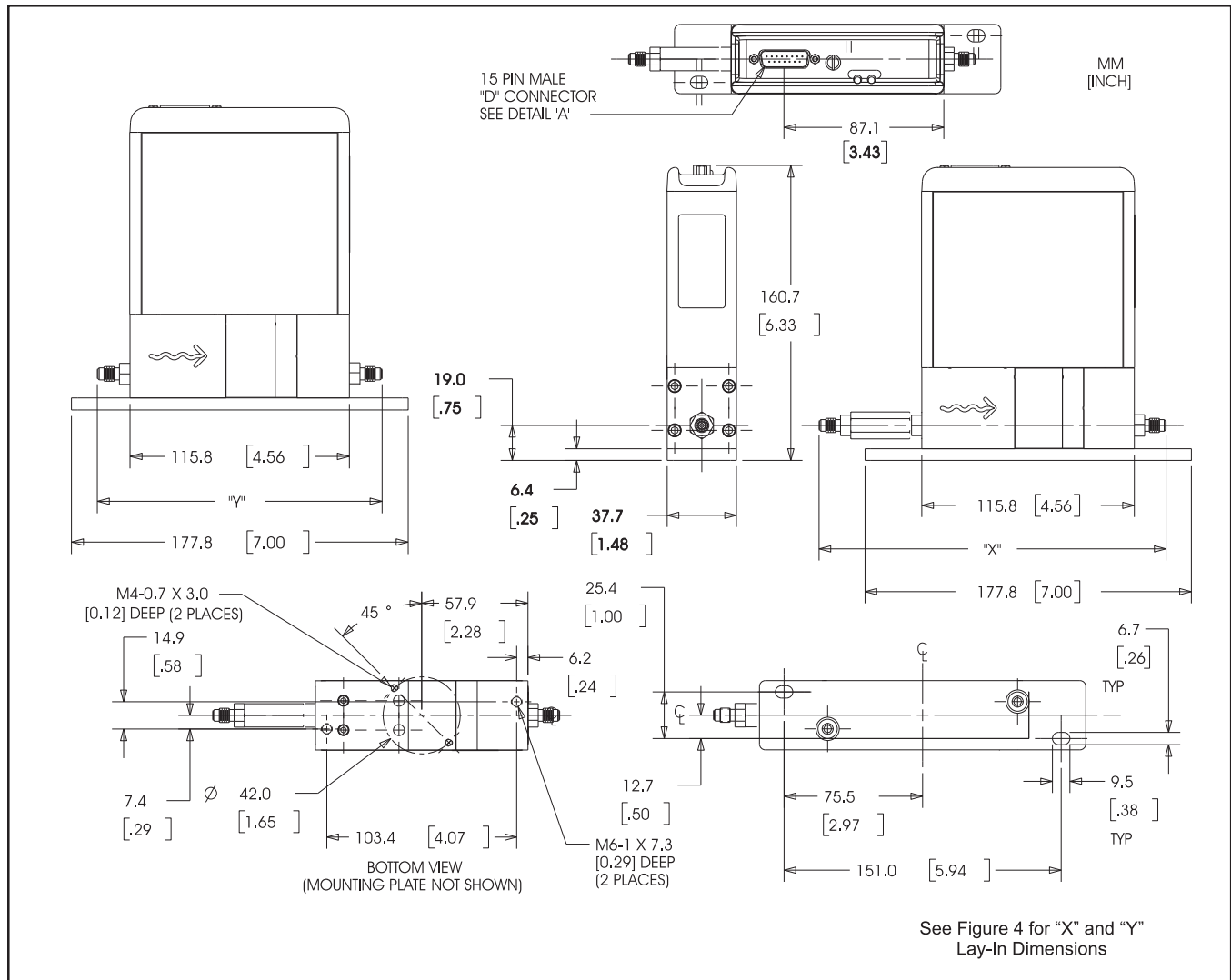

Figure 1-2 Dimensional Drawing QmB IP40

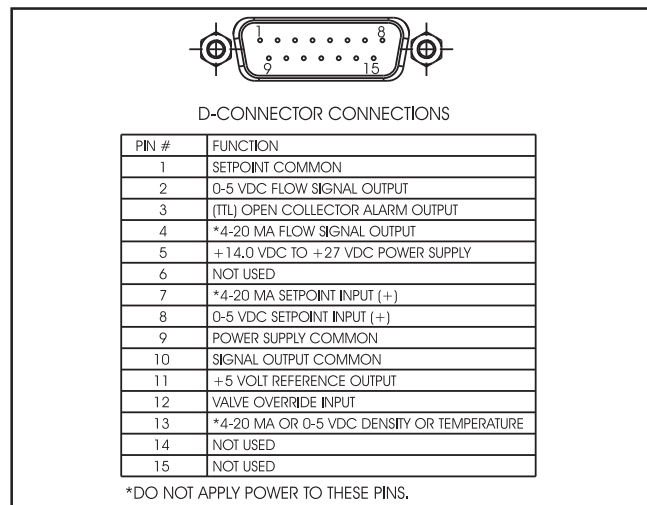

Figure 1-3 D-Connector Electrical Pin Connections

LAY-IN DIMENSIONS	INTEGRAL VALVE		REMOTE VALVE	
	"X" Dimension	"Y" Dimension	"X" Dimension	"Y" Dimension
1/16" Tube Compression	184.1 [7.25]* 167.3 [6.59]**	151.9 [5.98]* 135.1 [5.32]**	340.1 [13.39] 323.3 [12.73]	307.9 [12.12] 291.1 [11.46]
1/8" Tube Compression	192.7 [7.59]* 167.3 [6.59]**	160.5 [6.32]* 135.1 [5.32]**	348.7 [13.73] 323.3 [12.73]	316.5 [12.46] 291.1 [11.46]
1/4" Tube Compression	197.3 [7.77]* 166.8 [6.57]**	165.1 [6.50]* 134.6 [5.30]**	353.6 [13.92] 323.1 [12.72]	321.4 [12.65] 290.9 [11.45]
6 mm Tube Compression	197.6 [7.78]* 167.0 [6.78]**	165.4 [6.51]* 134.8 [5.31]**	353.9 [13.93] 323.2 [12.72]	321.7 [12.67] 291.0 [11.46]
1/8" NPT (F)	179.9 [7.08]	147.7 [5.81]	335.9 [13.22]	303.7 [11.96]
1/4" NPT (F)	189.3 [7.45]	157.1 [6.19]	345.3 [13.59]	313.1 [12.33]
1/8" VCR	182.6 [7.19]	150.4 [5.92]	338.6 [13.33]	306.4 [12.06]
1/4" VCR	200.9 [7.91]	168.7 [6.64]	356.2 [14.02]	324.0 [12.76]
1/4" VCO	188.2 [7.41]	156.0 [6.14]	344.2 [13.55]	312.0 [12.28]
3.2MM UPG	N/A	150.3 [5.92]	N/A	N/A
ANSI/ISA 76.00.02	N/A	Contact Factory	Not Available	

* OVERALL LENGTH FINGER TIGHT
** OVERALL LENGTH DIMENSION IS TO THE INTERNAL TUBE LOCATING SHOULDER

MM [INCH]

Figure 1-4 Lay-In Dimensions Integral and Remote Valves

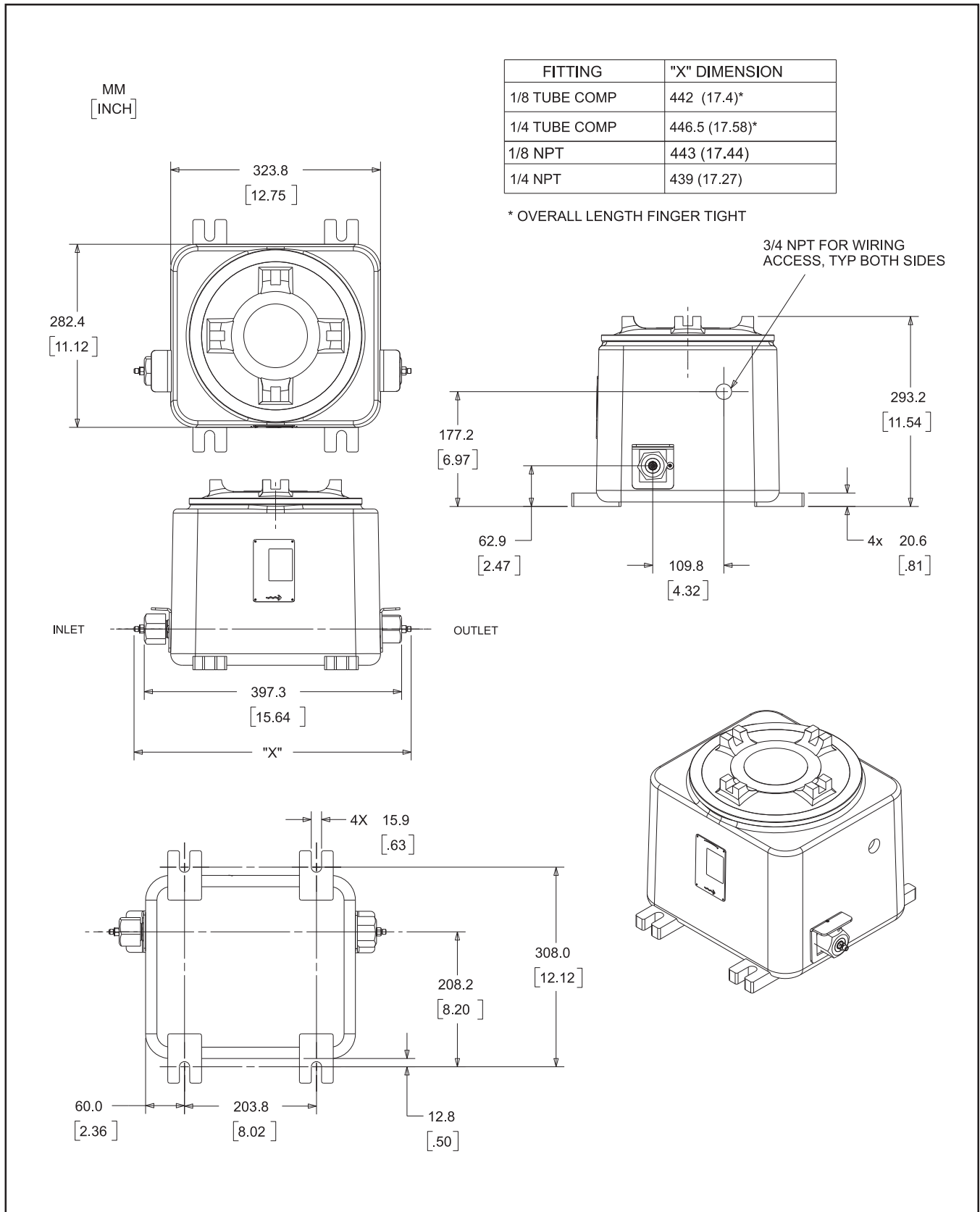

Figure 1-7 Dimensional Drawing QmB IP66XP

*THIS PAGE WAS
INTENTIONALLY
LEFT BLANK*

2-1 General

WARNING

Operating Procedure: Do not operate this instrument outside the specifications listed in Section 5. Before bringing the unit into operation, make sure that all fluid connections have been correctly tightened and that all necessary electrical connections have been made.

2-2 Receipt of Equipment

When the instrument is received, the outside packing case should be checked for damage incurred during shipment. If the packing case is damaged, the local carrier should be notified at once regarding their liability. A report should be submitted to your nearest Product Service Department.

Brooks Instrument

407 W. Vine Street
P.O. Box 903
Hatfield, PA 19440 USA
Toll Free (888) 554-FLOW (3569)
Tel (215) 362-3700
Fax (215) 362-3745
E-mail: BrooksAm@BrooksInstrument.com
<http://www.BrooksInstrument.com>

Brooks Instrument

Neonstraat 3
6718 WX Ede, Netherlands
P.O. Box 428
6710 BK Ede, Netherlands
Tel 31-318-549-300
Fax 31-318-549-309
E-mail: BrooksEu@BrooksInstrument.com

Brooks Instrument

1-4-4 Kitasuna Koto-Ku
Tokyo, 136-0073 Japan
Tel 011-81-3-5633-7100
Fax 011-81-3-5633-7101
Email: BrooksAs@BrooksInstrument.com

Remove the envelope containing the packing list. Carefully remove the instrument from the packing case. Make sure spare parts, accessories and documentation are not discarded with the packing materials. Inspect for damaged or missing parts.

2-3 Recommended Storage Practice

If intermediate or long-term storage is required, it is recommended that the instrument be stored in accordance with the following:

- a. In the original vacuum bag and shipping container.
- b. In a sheltered area with the following conditions:
Ambient temperature 70°C (160°F) maximum and 0°C (32°F) minimum.
- c. Relative humidity 45% nominal, 60% maximum, 25% minimum.

Upon removal from storage a visual inspection should be conducted to verify the condition of equipment is "as received".

QmB Series IP40, IP66, IP66XP

2-4 Return Shipment

Prior to returning any instrument to the factory, contact your nearest Brooks agent or a Brooks location listed below for a Return Materials Authorization Number (RMA#). Information describing the reason for return, details on the problems encountered, if any, as well as any requested work or corrective action requests must be included with the returned device.

Brooks Instrument

407 W. Vine Street
P.O. Box 903
Hatfield, PA 19440 USA
Toll Free (888) 554-FLOW (3569)
Tel (215) 362-3700
Fax (215) 362-3745
E-mail: BrooksAm@BrooksInstrument.com
<http://www.BrooksInstrument.com>

Brooks Instrument

Neonstraat 3
6718 WX Ede, Netherlands
P.O. Box 428
6710 BK Ede, Netherlands
Tel 31-318-549-300
Fax 31-318-549-309
E-mail: BrooksEu@BrooksInstrument.com

Brooks Instrument

1-4-4 Kitasuna Koto-Ku
Tokyo, 136-0073 Japan
Tel 011-81-3-5633-7100
Fax 011-81-3-5633-7101
Email: BrooksAs@BrooksInstrument.com

A copy of Brooks Instrument Decontamination Statement, as well as a Material Safety Data Sheet (MSDS) for the fluid(s) used in the instrument must be included with the returned device. This documentation is required before any Brooks personnel can begin processing the equipment. Copies of the forms can be obtained from any Brooks Instrument agent or on-line at www.brooksinstrument.com listed under the Support button.

Any assembly or part must be returned with a Return Material Authorization, which details the particulars about the device, the concerns and any process situations that need to be noted. A copy of the RMA is available on-line at www.brooksinstrument.com under the Support button.

2-5 Transit Precautions

To safeguard against damage during transit, transport the instrument to the installation site in the same container used for transportation from the factory if circumstances permit.

2-6 Fluid Connections**General Mounting Practices**

Use good piping practices to minimize transmitting any torque or bending loads onto the process connections on the Quantim. Always verify there are no leaks prior to starting Quantim on process fluid. The instrument is delivered from the factory with a rigid surface mounting plate. For optimum performance, this mounting plate should be used to mount Quantim to a rigid surface. If panel mounting is required, the bottom of the instrument is provided with two M4 and M6 (see dimensional drawings, Section A) mounting holes to properly install the instrument on a rigid flat plate. Panel mounting is not recommended for Quantim flow controllers with remote valve configuration.

⚠ WARNING

Any rotation of the inlet or outlet fitting during installation of a metal seal device may result in a leak. Always use two (2) wrenches when attaching gas lines to prevent rotation.

Prior to installation:

- a. Verify that tube fittings match the fitting type and size supplied with your Quantim instrument.
- b. Make certain that all piping and fittings are clean and free of obstructions for the instrument and filter.
- c. Assure that the final installation permits easy access to the instrument.

2-7 Mechanical Installation

(For Dimensional Drawings see Section 1-4 Dimensions)

⚠ CAUTION

When installing the Mass Flow device, care should be taken to prevent foreign materials from entering the instrument's inlet or outlet. Internal passages are very small. It is recommended that an inlet filter be used to limit the chance of clogging. Do not remove the protective end-caps until the actual moment of installation. When used with reactive fluids (some of which may be toxic), contamination or corrosion may occur as a result of plumbing leaks or improper purging. Plumbing should be checked carefully for leaks.

⚠ CAUTION

When installing the IP66 and IP66XP Mass Flow Devices, note that there are (2) 3/4" NPT conduit entries supplied. If both entries are not in use, the unused entry must be sealed via an approved method per the hazard level of the atmosphere in which it is installed.

Recommended installation procedures:

- a. All models should be mounted to a stable surface that is relatively free from mechanical shocks and mechanical vibration using the supplied mounting plate.
- b. Leave sufficient room for access to the electrical connections.
- c. Install in a manner that allows the instrument to be easily removed.
- d. Install the instrument with an appropriate filter on the fluid inlet side.
- e. It is recommended that a positive shutoff valve be installed downstream of the Quantim product to allow for proper zeroing after installation.

Manifold Mounting

If the Quantim is provided with the downport option it should be mounted to the proper manifold. Make sure the correct seals are used between the Quantim and the manifold to prevent leaks.

⚠ WARNING

When using ANSI/ISA SP-76 downport process connections, refer to substrate manufacturer's operating pressure limits (some substrates are rated lower than 70 bar / 1000 psi).

⚠ CAUTION

The control valve of the Quantim Mass Flow Controller provides precision control and is not designed for positive shutoff. If positive shutoff is required, it is recommended that a separate shut-off valve be installed in-line, downstream from the Quantim Mass Flow Controller.

⚠ CAUTION

If the power supply to the Quantim Mass Flow Controller is interrupted, a NORMALLY CLOSED valve will be fully closed. However, a shutoff valve is recommended if the process architecture requires it as the Quantim control valve may not provide positive shutoff.

⚠ WARNING

To prevent ignition of hazardous atmospheres disconnect supply circuits before opening. Keep cover tight when in operation. Conduit runs must have seal fittings installed within 3 inches of enclosure.

2-8 Process Mounting

The Brooks Quantim will function in any orientation if the Coriolis sensor and the control valve remain filled with process fluid. Entrapped gas in a liquid application and entrapped liquid in a gas application should be prevented as it may disturb the Coriolis sensor and the control valve.

Install the Brooks Quantim in the direction of the FLOW arrow.

The arrow indicating proper flow direction is engraved on the front of the instrument between the process fittings. (See Figure 2-1 below.)

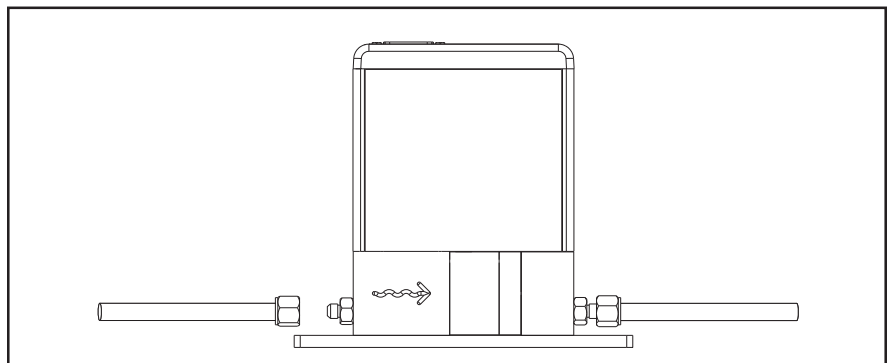

Figure 2-1 Flow Direction Through the Quantim, as Indicated by the Arrow Engraved on the Meter/Controller Body.

Horizontal Mounting

If installing the Brooks Quantim in a horizontal orientation, liquids should flow in the direction of the flow arrow. Situations of entrapped gas in the liquid process should be avoided. In liquid flow applications, it is recommended to mount the Quantim in an inverted attitude on the underside of the pipe to limit the possibility of entrapped gas collecting in the sensor, which can cause errors (See Figure 2-2).

For use in gas flow measurement, the Quantim should be mounted on the topside of the pipe to limit the possibility of entrapped fluid collecting in the sensor, which can cause errors. (See Figure 2-3).

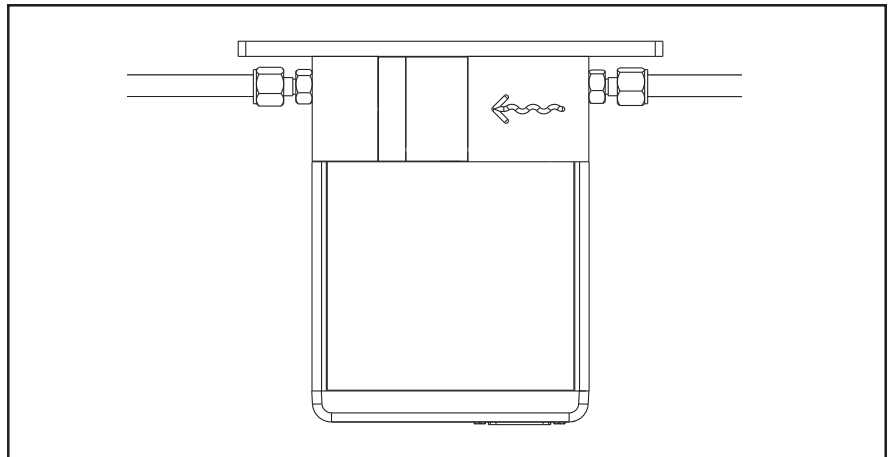

Figure 2-2 Horizontal Inverted Installation

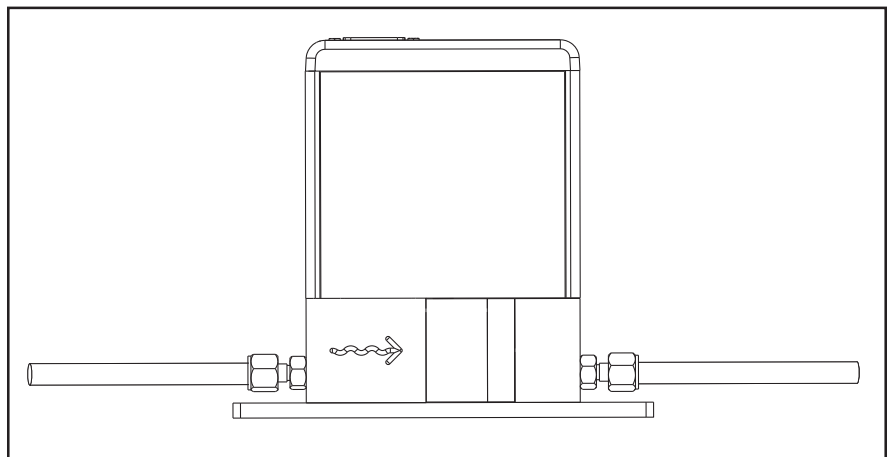

Figure 2-3 Horizontal Right Side Up Installation

QmB Series IP40, IP66, IP66XP

Vertical Mounting

If the Brooks Quantim is installed in a vertical orientation, for use in a liquid application liquid should flow upwards through the instrument to help minimize errors due to entrapped gas (See Figure 2-4). For gas flow vertical orientation, flow up or down is acceptable.

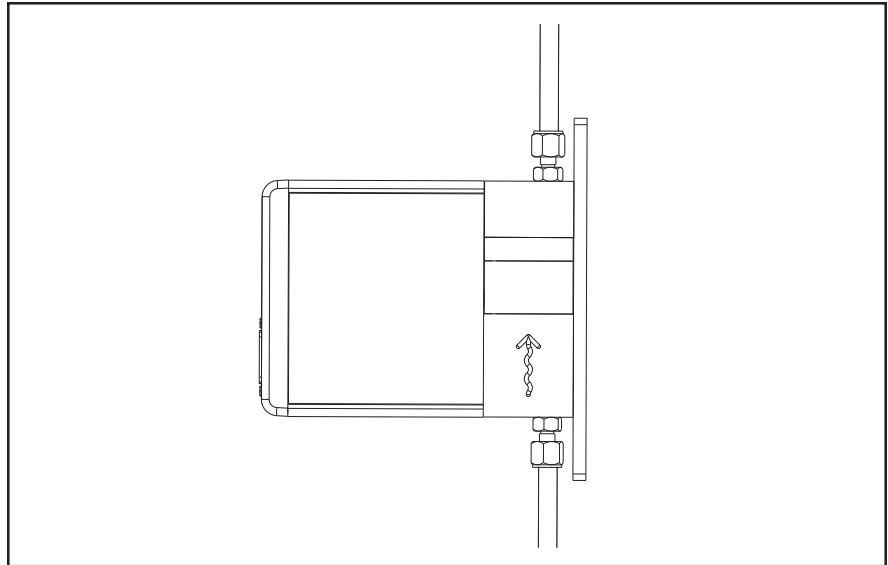

Figure 2-4 Vertical Flow Up Installation

2-9 Electrical Interfacing**Meter and Controller****Flow Output (Pins 2, 4 and 10)****Flow Output configuration is a factory selected option.**

Each Quantim instrument is calibrated as either 0-5 Vdc or 4-20 mA at the factory as specified when ordering.

Pin 2 indicates the flow rate, represented by a 0-5 Vdc signal proportional to flow, if so configured. Recommended load on Pin 2 is

>1K ohm. Pin 4 indicates the flow rate, represented by a 4-20 mA signal current proportional to flow, if so configured. Maximum series resistance on Pin 4 is 500 ohms. Do not apply power to Pin 4. The current and voltage signals are returned via Pin 10.

Analog Setpoint Input (Pins 7, 8 and 1; Controller models only)**Signal Input configuration is a factory selected option.**

The Mass Flow Controller can be used either with a current or voltage setpoint as configured when ordered. If configured for current (4-20 mA) setpoint, connect the setpoint signal to Pin 7 and the setpoint return signal to Pin 1. Input impedance on Pin 7 is 250 ohms. Do not apply power to Pin 7. If configured for voltage (0-5 Vdc) setpoint, connect the setpoint signal to Pin 8 and the setpoint return to Pin 1. Input impedance to Pin 8 is 200K ohms.

Power Supply (Pin 5 and Pin 9)

Both Mass Flow Meter and Controller models are connected via Pins 5 (+14 to +27 Vdc) and 9 (power supply common) on the customer connector. See Section 5, Functional Specifications for current requirement.

⚠ WARNING

With regard to power supply connections, the user must ensure that the minimum required voltage and current is available at the mass flow device taking into consideration any losses in the interconnecting cable.

Valve Override (Pin 12; Controller models only)

To open or close the control valve independently of the setpoint signal (e.g. for process reasons), Pin 12 is available to carry a valve override signal. Leave floating (i.e. not connected) to allow for normal control operation. Input impedance on Pin 12 is >50K ohms.

>5 Vdc @ Valve Open
 0 Vdc @ Valve Closed

Density or Temperature Output (Pin 13 and Pin 10)

Pin 13 indicates the density or temperature, represented by a 4-20 mA or 0-5 Vdc signal, proportional to density or temperature. The current and voltage signals are returned via Pin 10. Maximum series resistance on Pin 3 is 500 ohms when configured for 4-20 mA. Recommended load on Pin 13 is >100K ohms when configured for 0-5 Vdc. Do not apply power to Pin 13.

Alarm Output (Pin 3 and Pin 9)

Pin 3 indicates an alarm condition as an open drain FET configuration. Maximum voltage is 30 Vdc, maximum current is 100 mA. (See Figure 2-6 on page 2-8.)

Table 2-1 Electrical Interfacing for Quantim

PIN NO.	FUNCTION	Controller	Meter
1	Setpoint Common	•	N/A
2	0 - 5 Vdc Flow Signal Output	•	•
3	Alarm Output	•	•
4	*4 - 20 mA Flow Signal Output	•	•
5	+14 Vdc to +27 Vdc Power Supply	•	•
6	not used		
7	*4 - 20 mA Setpoint Input	•	N/A
8	0 - 5 Vdc Setpoint Input	•	N/A
9	Power Supply Common	•	•
10	Signal Output Common	•	•
11	+5 Vdc Reference Output	•	•
12	Valve Override Input	•	N/A
13	*4 - 20 mA or 0 - 5 Vdc Density or Temperature	•	•
14	not used		
15	not used		

* Do not apply power to these Pins.

QmB Series IP40, IP66, IP66XP

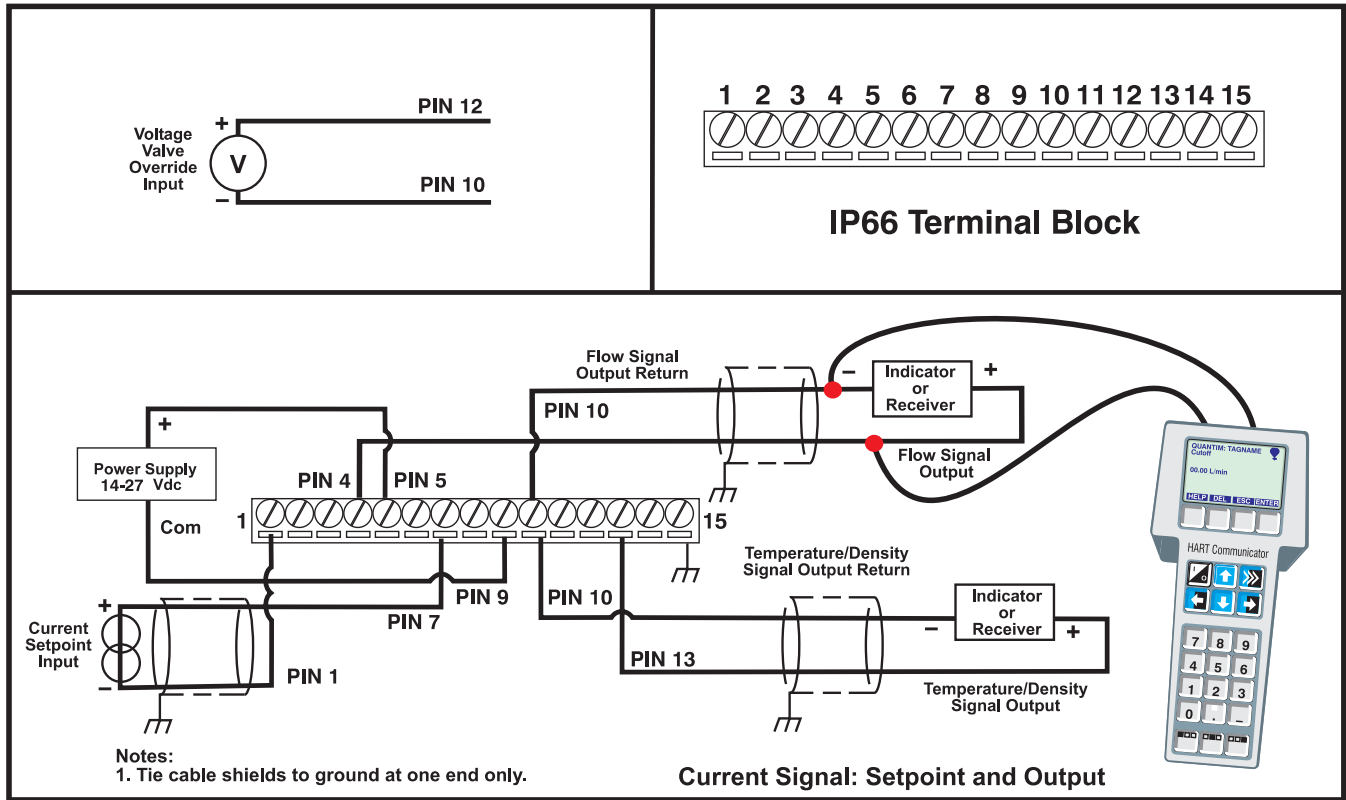

Figure 2-5 Proper Wiring of a Brooks QmB IP66 NEMA 4X

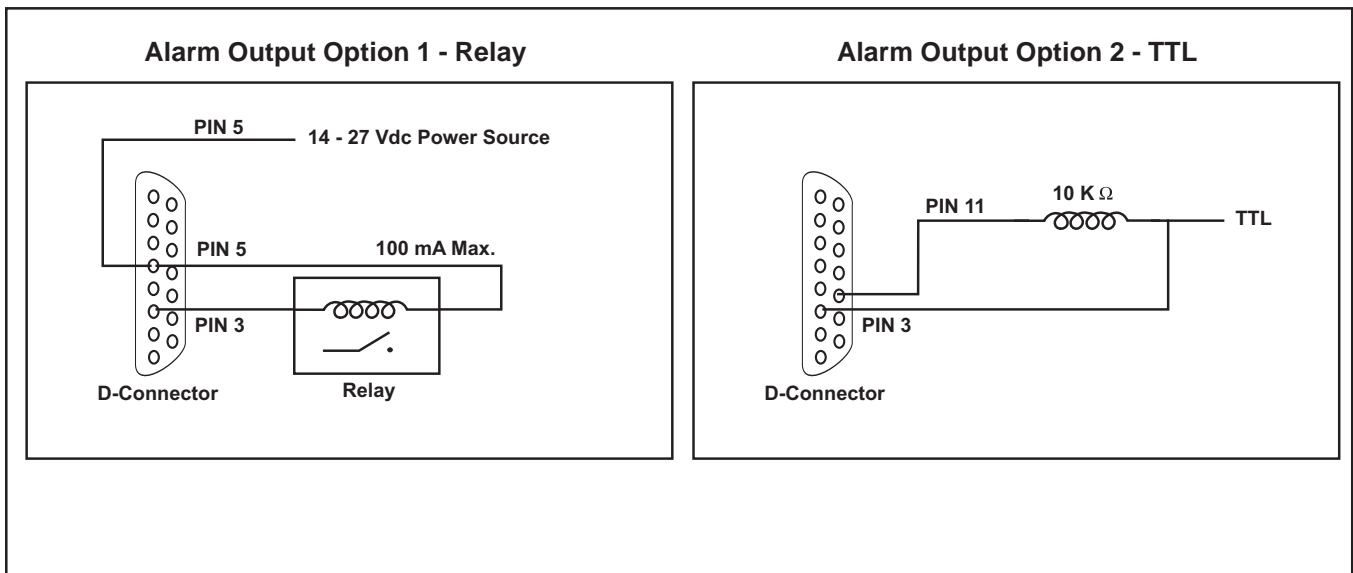

Figure 2-6 Alarm Output Wiring Options

2-10 Interconnection with Peripheral Equipment

Quantim Meter/Controller and Brooks Instrument Models 0152, 0154 or 0254 interconnection.

The following cables are available for connection of the Quantim Mass Flow Meter/Controller to the Brooks Microprocessor Control & Read-out Unit: Models # 0152, 0154 or 0254

Length: 3ft (1m);	part number	124Y054AAA
Length: 5ft (1.5m);	part number	124Y050AAA
Length: 10ft (3m);	part number	124Y051AAA
Length: 25ft (7m);	part number	124Y052AAA
Length: 50ft (15m);	part number	124Y053AAA

Or in case both Flow and Density or Temperature functions have to be made available: (For 4-20 mA secondary output only)

Length: 5ft (1.5m);	part number	124Z906ZZZ
Length: 10ft (3m);	part number	124Z907ZZZ
Length: 25ft (7m);	part number	124Z908ZZZ
Length: 50ft (15m);	part number	124Z909ZZZ

The following open frame cables are available for connection of the QUANTIM Mass Flow Meter/Controller to any secondary electronic device.

Length: 5ft (1.5m);	part number	124Z361AAA
Length: 10ft (3m);	part number	124Z362AAA
Length: 25ft (7m);	part number	124Z363AAA
Length: 50ft (15m);	part number	124Z435AAA
Length: 75ft (22m);	part number	124Z876AAA
Length: 100ft (30m);	part number	124Z868AAA
Length: 150ft (45m);	part number	124Z757AAA
Length: 200ft (60m);	part number	124Z773AAA

See Figure 2-7 for Wire Color Code Diagram

Cable Shielding Earth

Cable requirements:

Compliance with EMC directive 89/336/EEC, requires that the equipment be fitted with fully screened signal cables with at least 80% shielding. The cable shielding should be connected to the D-connector's metal shell and have 360° shielding at both ends. The shielding should be connected to an earth terminal.

QmB Series IP40, IP66, IP66XP

PIN	COLOR	FUNCTION
1	BLK	SETPOINT COMMON
2	WHT	0-5 VDC FLOW SIGNAL OUTPUT
3	RED	(TTL) OPEN COLLECTOR ALARM OUTPUT
4	GRN	*4-20 MA FLOW SIGNAL OUTPUT
5	ORG	+14.0 VDC TO +27 VDC POWER SUPPLY
6	BLUE	NOT USED
7	WHT / BLK	*4-20 MA SETPOINT INPUT (+)
8	RED / BLK	0-5 VDC SETPOINT INPUT(+)
9	GRN / BLK	POWER SUPPLY COMMON
10	ORG / BLK	SIGNAL OUTPUT COMMON
11	BLU / BLK	+5 VOLT REFERENCE OUTPUT
12	BLK / WHT	VALVE OVERRIDE INPUT
13	RED / WHT	*4-20 MA OR 0-5 VDC DENSITY OR TEMP.
14	GRN / WHT	NOT USED
15	BLU / WHT	NOT USED

* DO NOT APPLY POWER TO THESE PINS

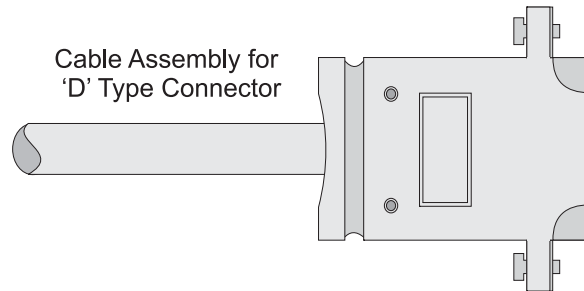

Figure 2-7 Wire Color Codes for 'D' Connector Assembly

3-1 Operating Procedure

⚠ CAUTION

Any sudden change in system pressure may cause mechanical damage to elastomer materials. Damage can occur when there is a rapid expansion of fluid that has permeated elastomer materials. The user must take the necessary precautions to avoid such conditions.

After the wiring cable has been connected, power can be supplied to the instrument. During initialization, the instrument remains in start-up mode for about 5 seconds. The START-UP mode is indicated by the alternately flashing red/green status LEDs on the Meter/Controller.

LEDs are visible through the top cover of the instrument in the NEMA 1/ IP40 package (See Figure 3-1). The top cover must be removed to gain access to the LEDs in the NEMA 4X / IP66 and the Explosion Proof IP66XP package options.

Status LED

The Status LED, indicates the operation condition of the instrument. During start-up, the status LED blinks red/green once per second to indicate proper start-up operation of the meter/controller. Then a solid green is displayed to indicate proper function.

The status LED will be illuminated a solid green color for the meter/controller, indicating that the instrument is ready for operation.

If the status LED is illuminated a solid red color, a START-UP issue has been determined by the onboard diagnostic programs. This condition can only be cleared by cycling power to the instrument. If the issue persists, call the Quantim Helpdesk at Brooks Instrument.

Customer Service

The Brooks Helpdesk is available to assist with start-up if you experience issues you cannot solve on your own. You will be asked to provide the model code and serial number of your Brooks equipment, which will assist us in answering your questions. For telephone references, please refer to the back cover of this instruction manual.

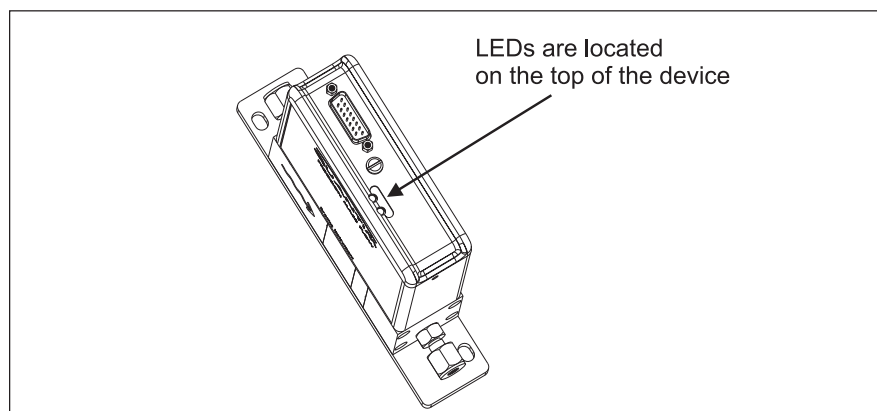

Figure 3-1 Location of the LEDs

QmB Series IP40, IP66, IP66XP

3-2 Zero Adjustment

After the Brooks Quantim has been fully installed, you must perform the zeroing procedure. This procedure ensures that the instrument responds properly to zero flow condition and sets a baseline for flow. To perform the zeroing operation on the meter/controller, use the ZERO button, which is located on top right hand side (outlet side) of the instrument. Zero button must be pressed for at least 3 seconds to initiate zeroing procedure. The status LED will flash red on and off during the zeroing procedure. (See Figure 3-2).

⚠ CAUTION

After the instrument has been installed, you must perform the re-zeroing procedure. See Section 3-2 for the re-zeroing procedure. A true zero flow condition must be present and the Coriolis sensor and control valve must both be completely full of process fluid during the re-zeroing procedure. This is done best by eliminating any pressure differential across the instrument. A shutoff valve, downstream from the instrument, is recommended to halt flow during the re-zeroing procedure.

Failure to zero the instrument after initial startup could cause measurement error.

Zero the instrument before putting the instrument in operation.

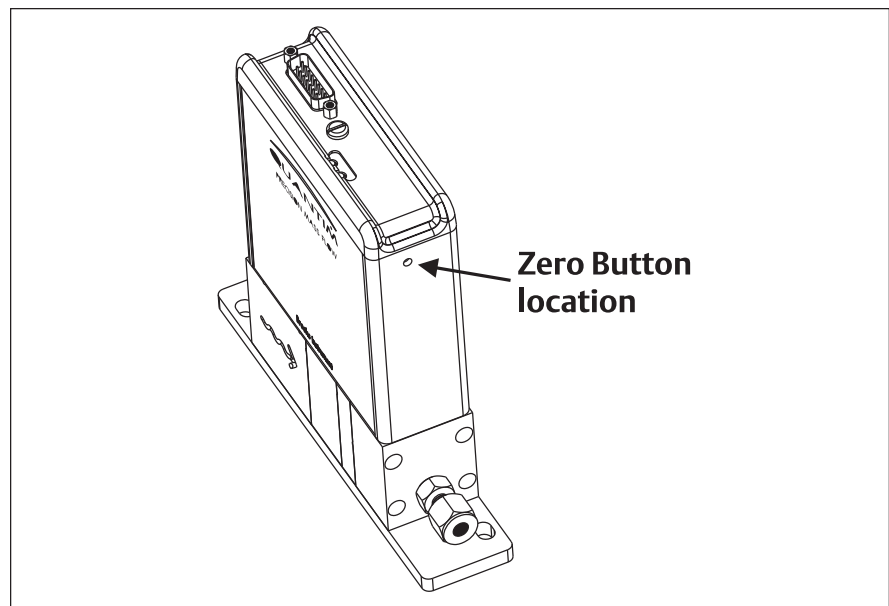

Figure 3-2 Location of the Zero Button.

Zero Procedure

1. Prepare the instrument for zeroing:
 - a. Install the instrument according to the instructions in this manual.
 - b. Power-up sequence. Isolate device from flow pressure when applying power. Once the status indicator is illuminated green, pressure may be applied.
 - c. Apply power to the instrument and allow approximately 45 minutes to reach a stable condition.
 - d. Run the process fluid to be measured and controlled through the instrument until the temperature of the instrument approximates the normal process operating temperature. Use the Valve Override (V.O.R.) function to fully open the control valve to facilitate temperature stabilization.
2. Once the instrument has reached process temperature, close the external shutoff valve downstream from the instrument and wait for the flow to stop. Set the control function to zero and V.O.R. to normal once flow has stopped and all pressure differential across the instrument has been bled off.
3. Make sure that the instrument is completely filled with the process fluid under normal process conditions of temperature, pressure, density, etc. make sure there is no entrapped gas in the sensor tube and ensure a zero flow condition through the instrument.

⚠ CAUTION

Flow through the instrument during zeroing procedure will result in an inaccurate zero setting.

Make sure fluid flow through the instrument is completely stopped during the zeroing procedure.

4. After confirming that fluid flow through the instrument is completely stopped, actuate the zero function as previously stated.
5. The default zero sample interval is 30 seconds. A successful zero operation on the controller and meter will be indicated by a solid green color status LED. A solid red color status LED indicates a failed zero process. A non-steady flash will indicate a failed condition. A failed condition can only be cleared by a power cycle.
6. Once the status LED turns green, zero process is complete and the instrument is ready for operation.

Please note that zero command will only be accepted when the output change is less than 1% of the maximum full scale of the device. This logic prevents an accidental zero command from being initiated when flow is present, through the device.

QmB Series IP40, IP66, IP66XP

3-3 Calibration Procedure

The Quantim calibration is not described in this manual.
If your Quantim requires calibration, please contact one of the
Brooks Instrument locations for technical assistance
(See Back Cover for Contact Information).
Or visit our website: [www.BrooksInstrument.com/Service & Support](http://www.BrooksInstrument.com/Service%20&%20Support).

4-1 General

There are no routine maintenance procedures required to keep the Quantim device in good operating condition. It is however, very important to keep the fluid entering the Quantim clean, and as a result periodic replacement of the inlet guard filter is recommended at a frequency determined by the cleanliness of the fluid. At a minimum this guard filter should be replaced on an annual basis.

	<p>⚠ WARNING</p> <p>METER/CONTROLLER SEAL COMPATIBILITY</p>
---	---

Products in this manual may contain metal or elastomeric seals, gaskets, O-rings or valve seats. It is the "user's" responsibility to select materials that are compatible with their process and process conditions. Using materials that are not compatible with the process or process conditions could result in the Meter or Controller leaking process fluid outside the pressure boundary of the device, resulting in personnel injury or death.

It is recommended that the user check the Meter or Controller on a regular schedule to ensure that it is leak free as both metal and elastomeric seals, gaskets, O-rings and valve seats may change with age, exposure to process fluid, temperature, and /or pressure.

<p>⚠ WARNING</p> <p>If it becomes necessary to remove the MFC/MFM from the system after exposure to toxic, pyrophoric, flammable or corrosive fluids, purge the flowmeter thoroughly before disconnecting the fluid connections. Failure to correctly purge the MFC/MFM could result in fire, explosion or death. Corrosion or contamination of the MFC/MFM upon exposure to air, may also occur.</p>
--

<p>⚠ CAUTION</p> <p>It is important that this MFC/MFM only be serviced by properly trained and qualified personnel.</p>
--

4-2 Troubleshooting

System Checks**⚠ WARNING**

Internal seals and component alignments are extremely critical within this device. Improper servicing of your Quantim can cause malfunction of the device and/or personal injury. This device must be serviced by factory personnel only. There are no customer serviceable components within the device. Disassembly of this device voids all warranties, explicit or implied.

Quantim Flow Meters and Controllers are typically used as a critical component in fluid systems. These systems can be complex in nature and therefore isolating a malfunction has to be done with a system perspective. An incorrectly diagnosed malfunction can cause many hours of unnecessary downtime. If possible, perform the following system checks before removing a suspect Mass Flow Meter or Controller for bench troubleshooting or return to the factory (especially if the system is new):

1. Identify a low resistance common connection and make sure that the correct power supply voltage and signals are present at the connector of the Quantim device.
2. Verify that the process fluid connections have been made correctly, and that they have been tested for leaks.
3. If the Mass Flow Controller appears to be functioning but cannot achieve setpoint, verify that there is sufficient inlet pressure and pressure drop at the controller to provide the required flow.
4. Flow control instability can be a result of using Quantim in a system that includes other active control elements such as pressure regulators. Depending on the tuning constants used in the Quantim and the control dynamics of the other active elements, these devices can interfere with each other and cause flow instabilities. It is very important to take a complete system perspective when applying Quantim to flow control applications.

Table 4-1 Troubleshooting

Observation	Cause	Resolution
<p>Oscillating mass flow output can cause diagnostic alarm</p>	<p>Bubbles dissolved in the liquid. High pressure push gas can cause bubbles to dissolve in fluid. Bubbles then form at the valve due to pressure drop, upsetting valve.</p> <p>Oscillating pump pressure used to move the fluid. Piston action can cause pressure oscillations, upsetting valve.</p> <p>Pressure drop or inlet pressure deviates from calibrated values.</p> <p>Valve out of adjustment.</p> <p>Unstable inlet pressure.</p> <p>Defective PC board.</p> <p>Valves are tuned digitally and mechanically for a particular ΔP.</p>	<p>Use a degasser or use Helium as a push gas with 25-50ft. of Teflon[®] tube. Helium is a light gas and can permeate the Teflon tube to release bubbles.</p> <p>Avoid using push gas. Use a pump or bladder tank to prevent head pressure.</p> <p>Pressure regulators on inlet and outlet of Quantim to stabilize pressure variations.</p> <p>Adjust pressure to original specifications.</p> <p>Contact Brooks Instrument.</p> <p>Check external pressure regulator.</p> <p>Contact Brooks Instrument.</p> <p>Operate Quantim at specified pressure conditions.</p>
<p>Valve will not open or fully close</p>	<p>Valves are tuned digitally and mechanically for a particular ΔP. Proper valve response requires just the right amount of force to be applied by the valve. With too much or too little ΔP the valve will be mis-tuned.</p> <p>Mounting attitude is different from calibration attitude; Reason, gravity effects could pull valve open or closed.</p>	<p>Operate Quantim at specified pressure conditions.</p> <p>Check valve operation with the Brooks Service Tool.</p> <p>Mount Quantim in the specified mounting attitude.</p>
<p>No Flow or unable to achieve full flow</p>	<p>Insufficient inlet pressure or pressure drop.</p> <p>Clogged Valve Orifice or Sensor.</p>	<p>Adjust pressures, inspect in-line filters and clean/replace as necessary</p> <p>Back flush the device with a solvent or purge gas with valve override "Open" (if controller).</p>

QmB Series IP40, IP66, IP66XP

Table 4-1 Troubleshooting (continued)

Observation	Cause	Resolution
No Flow or unable to achieve full flow	<p>Particulates in the flow stream.</p> <p>Agglomeration of fluid at orifice.</p> <p>Chemical deposits.</p> <p>Poor filtration of process fluid.</p> <p>Valve out of adjustment (applicable to Controller).</p>	<p>If the device has an external control valve you can replace or disassemble and clean the valve. (See Section 4-3)</p> <p>Use an inlet filter.</p> <p>Consider a larger orifice (valve stability could suffer).</p> <p>Institute regular PM back flushing.</p> <p>Install proper filtration.</p> <p>Contact Brooks Instrument.</p>
Valve out of adjustment	<p>Valve guide spring failure (applicable to Controller).</p> <p>Valve override input is grounded</p> <p>Defective electronic board</p>	<p>Contact Brooks Instrument.</p> <p>Check the valve override input (Pin12).</p> <p>Contact Brooks Instrument.</p>
Output signal follows Setpoint at higher Setpoints but not at lower Setpoints	Control valve leaks or is stuck open.	<p>Exercise the control valve alternating between valve override "open" and closed. If problem persists backflush the device with a solvent or purge gas with valve override "open".</p> <p>If the device has an external control valve you can replace or disassemble and clean the valve. (See Section 4-3)</p>
Output signal stays in approx. 5.5 Vdc or 22 mA (regardless of setpoint) and there is flow through the meter/controller	<p>Valve leaks or is stuck open (applicable to Controller).</p> <p>+15 Vdc applied to the valve override input (applicable to Controller).</p> <p>Defective PC board.</p>	<p>Backflush the device with a solvent or purge gas with valve override "open".</p> <p>If the device has an external control valve you can replace or disassemble and clean the valve. (See Section 4-3)</p> <p>Check the valve override terminal (Pin 12).</p> <p>Contact Brooks Instrument.</p>

Bench Troubleshooting

⚠ WARNING

If it becomes necessary to remove the instrument from the system power to the device is disconnected at the power supply.

⚠ WARNING

If it becomes necessary to remove the instrument from the system after exposure to toxic, pyrophoric, flammable or corrosive chemicals, purge the instrument thoroughly with an inert fluid such as water, alcohol, nitrogen, clean dry air or some other appropriate fluid before disconnecting the fluid connections. Failure to correctly purge the instrument could result in fire, explosion or death. The Quantim Mass Flow device may also become corroded or contaminated upon exposure to air.

Quantim Bench Testing (Refer to Figure 4-1)

1. Establish the proper electrical connection between the Quantim MFC/MFM. Do not connect the device to a fluid source yet.
 - a. Connect a +14 Vdc to +27 Vdc power supply to Pin 5 and power supply common to Pin 9.
 - b. Connect a voltage output signal read-out device (4-1/2 digit voltmeter recommended) onto Pin 2 (+) and Pin 10 (common).
 - c. If applicable, connect current output signal read-out device onto Pin 4 (+) and Pin 10 (common).
 - d. Switch on power and allow the instrument to stabilize.
 - e. In case of a MFC, adjust the setpoint input to zero.
2. Observe the output signal and if necessary, perform the zero adjustment procedure as outlined in Section 3-2.
 - a. Only perform the zero operations with the Coriolis Sensor filled with either 100% fluid or 100% gas at the appropriate pressures and ensure there is no fluid flowing through the device (differential pressure = 0 psi).
 - b. Connect the Quantim to a pressurized supply of inert fluid (for example high purity water). Fill the Quantim instrument completely taking care there is no entrained gas in the sensor and perform the zero operation as described in Section 3-2.
 - c. When applying Quantim to measure a gas, fill the sensor with an inert gas (nitrogen or clean dry air) at a pressure near the process operating pressure.
 - d. If the output signal does not zero properly, please contact Brooks Instrument for technical assistance.
3. For a MFC connect a 0-5 Vdc source to Pin 8 and return to Pin 1 or connect 0-20 mA source to Pin 7 and return to Pin 1.
(See X-CM-Qm-HART-eng instruction manual for complete HART 4-20 mA I/O electrical hookups).
4. Provide an electrical signal to the Quantim representing a setpoint of 50% of full scale flow and adjust the inlet and outlet pressures to calibration conditions.

QmB Series IP40, IP66, IP66XP

4. Provide an electrical signal to the Quantim representing a setpoint of 50% of full scale flow and adjust the inlet and outlet pressures to calibration conditions.
5. Verify that the electrical output signal reaches 100% of flow. For MFC applications vary the setpoint over the 1% to 100% range and verify that the output signal matches the setpoint.
 - a. If possible, connect a flow measurement device (such as a rotometer) to the Quantim outlet to monitor the actual flow behavior.
6. If the Quantim is functioning correctly, the problem may lie elsewhere in the flow system. Re-verify the installation as well as the upstream/downstream fluid system configuration.
7. Please contact Brooks Instrument for further assistance in troubleshooting. Refer to the back cover of this manual for contact information.

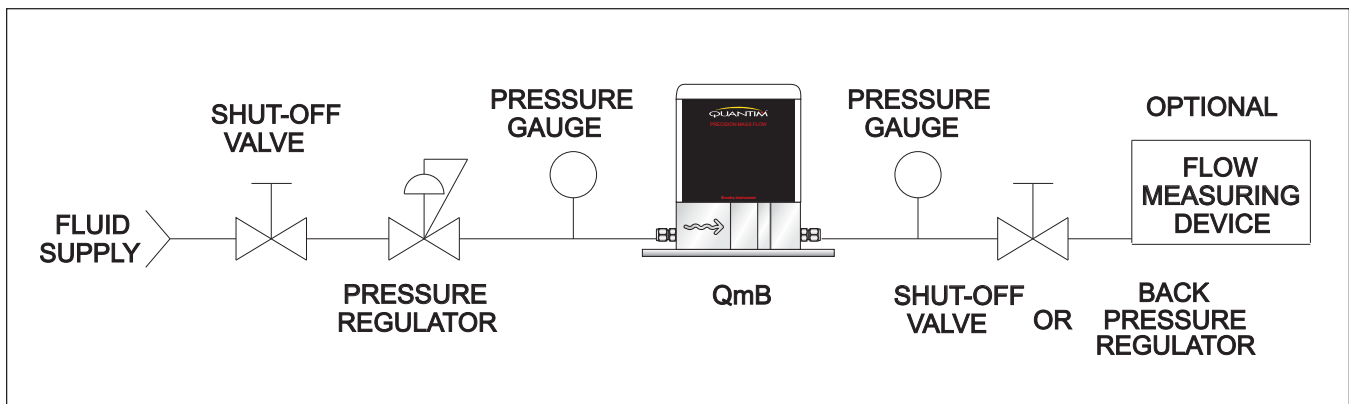

Figure 4-1 Bench Troubleshooting Circuit

4-3 External Valve Service

⚠ WARNING

These instructions must be used in conjunction with the instructions within this manual. Careful attention must be paid to the “essential instructions” before proceeding with any service work or serious injury may result.

Valve Disassembly

The numbers in () refer to the parts in the exploded view diagram Figure 4-2.

⚠ WARNING

Do not attempt to disassemble the valve until pressure has been removed and purging has been performed. Hazardous fluid, gas or liquid, may be trapped in the valve assembly which could result in explosion, fire or serious injury.

1. Remove valve nut, item (9).
2. Remove coil cover and coil, item (8).
3. Remove the four valve stem screws, item (7). Discard and replace with new fasteners. Do not re-use these components!
4. Carefully remove the valve stem, item (6). The valve seat, item (5) may be stuck in the stem, use care not to drop this part. Small tweezers can be used to remove item (5) if stuck in stem recess.

⚠ CAUTION

Do not scratch any of the valves sealing surfaces; inside stem cavity, orifice or seat. Damage to any of these components will cause improper valve performance or possible leakage.

5. Remove stem seal O-ring, item (3) from the valve body, item (1). It is recommended that the seal be discarded and replaced with a new un-used part.
6. Remove the orifice, item (4). Care must be taken to prevent damage to the coplanar top side surface and the lower sealing surface!
7. Remove the lower metal seal, item (2). This part will most likely be found on the bottom of the orifice, item (4) or in the bottom of the valve body, item (1). **Discard this seal as it is a one time use only!** This metal seal must be replaced with a new part or damage to the valve body and/or the orifice can result.
8. Examine the valve body, item (1) and clean if necessary.

Clean all parts prior to inspection and re-assembly using a solvent and soft brush or clean in an ultrasonic cleaner. Care must be taken not to damage any of the valve sealing surfaces.

QmB Series IP40, IP66, IP66XP

Assembly

1. Examine all parts for signs of wear or damage, replace as necessary. Refer to the parts list Figure 4-3.
2. Install the metal seal, item (2) in the center of the valve body, item (1).
3. Install the orifice, item (3) in the valve body, item (1).
The lower protrusion on the orifice must center in the orifice seat! The seal must be new and un-used.
4. Install the valve seat, item (5) in the valve cavity on top of the orifice.
5. Install O-ring, item (3) in the valve body, item (1). It is recommended that a new O-ring be used. Refer to parts list in Figure 4-3. When ordering the O-ring specify the correct compound i.e. Viton, Kalrez etc. depending upon your specific process.
6. Install the valve stem, item (6) over the valve seat, item (5) and center of the valve body, item (1).
7. Install the four valve screws, item (7) until they make light contact with the base of the valve stem, item (6). Torque the valve screws in a diagonal pattern in three increments slowly rising to a final torque value of 175 inch-pounds (20 N-m). Refer to Figure 4-4.
8. Install the valve coil, item (8).
9. Install the valve cover, item (9).
10. Install the valve nut, item (10) hand tight (snug).
11. Pressure and leak test to local standards.

Note: Standard Brooks Instrument pressure test is 1.5 times the design pressure marked on the valve and a helium leak test at 1×10^{-9} bar .cc/s helium maximum.

Note: The above leak test only evaluates the outbound seals. The inbound seal should be also evaluated. This can be accomplished while the unit is on the bench or when returned to normal service.

Item No.	Description	Part Number	Quantity
9	Valve Nut	573Z275CEF	1
8	Coil Cover Assembly	185Z314AAA	1
7	Socket Head Screw	751Z152AAA	4
6	Stem	949Z256QOT	1
5	Plunger Assembly	622Z252QOG	1
4	Orifice .014 dia.	577Z559BMG	1
3a	Stem O-ring, Kalrez	375B024TTA	1
3b	Stem O-ring, Viton	375B024QTA	
3c	Stem O-ring, Buna	375B024SUA	
3d	Stem O-ring, EPDM	375B024SOA	
2	Orifice Seal	763Z075AAA	1
1	Valve Body	092Y320BMT	1

Figure 4-2 Parts List

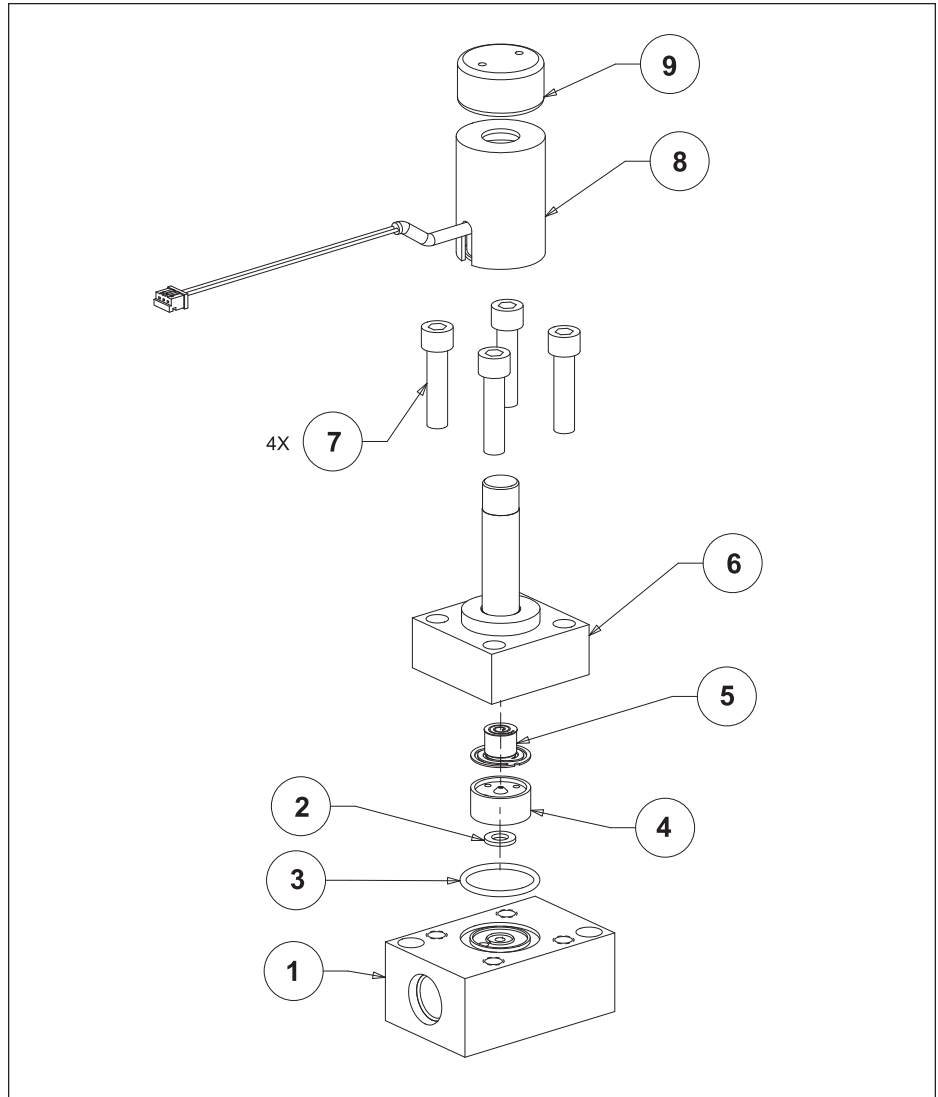

Figure 4-3 Exploded Diagram of Valve Assembly

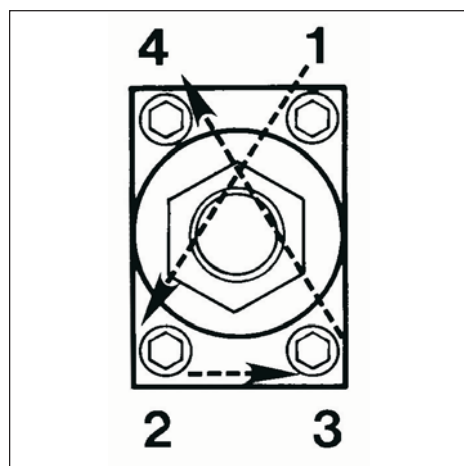

Figure 4-4 Valve Torque Pattern

*THIS PAGE WAS
INTENTIONALLY
LEFT BLANK*

Installation and Operation Manual

X-CM-QmB-eng
Part Number: 541B029AAG
June, 2011

QmB Series IP40, IP66, IP66XP

TRADEMARKS

Brooks Brooks Instrument, LLC
Brooks Service Tool Brooks Instrument, LLC
Quantim Brooks Instrument, LLC
HART HART Communications Foundation
Hastelloy Haynes International
Kalrez DuPont Performance Elastomers
Viton DuPont Performance Elastomers
VCO Cajon Co.
VCR Cajon Co.

Quantim Patent Numbers as follows:

Argentina AR026329B1, AR021594B1
Australia 778137, 771345, 782183
China ZL00817949.2, ZL02823425.1, 171140
Federation of Russia 2272257, 2263284, 2277227
Germany 40004270.3
Hong Kong HK1051720
India 199406
Indonesia ID0015789
Japan 1111950, 3904926
Malaysia MY-128330-A
Mexico 242129, 244688, 231280
Singapore 88632, 81430, 103761
South Korea 678430
Switzerland 127118
UK 2092458
US D436876, 4843890, 4996871, 5231884, 5295084,
5555190, 5687100, 5929344, 6226195, 6476522, 6487507, 6505131,
6505135, 6512987, 6513392, 6526839, 6748813,
6769301, 7032462, 7111519, 7117751, 7114517, 7204679
Counterparts in other countries and other patents pending

QmB Series IP40, IP66, IP66XP

LIMITED WARRANTY

Seller warrants that the Goods manufactured by Seller will be free from defects in materials or workmanship under normal use and service and that the Software will execute the programming instructions provided by Seller until the expiration of the earlier of twelve (12) months from the date of initial installation or eighteen (18) months from the date of shipment by Seller. Products purchased by Seller from a third party for resale to Buyer ("Resale Products") shall carry only the warranty extended by the original manufacturer.

All replacements or repairs necessitated by inadequate preventive maintenance, or by normal wear and usage, or by fault of Buyer, or by unsuitable power sources or by attack or deterioration under unsuitable environmental conditions, or by abuse, accident, alteration, misuse, improper installation, modification, repair, storage or handling, or any other cause not the fault of Seller are not covered by this limited warranty, and shall be at Buyer's expense.

Goods repaired and parts replaced during the warranty period shall be in warranty for the remainder of the original warranty period or ninety (90) days, whichever is longer. This limited warranty is the only warranty made by Seller and can be amended only in a writing signed by an authorized representative of Seller.

BROOKS SERVICE AND SUPPORT

Brooks is committed to assuring all of our customers receive the ideal flow solution for their application, along with outstanding service and support to back it up. We operate first class repair facilities located around the world to provide rapid response and support. Each location utilizes primary standard calibration equipment to ensure accuracy and reliability for repairs and recalibration and is certified by our local Weights and Measures Authorities and traceable to the relevant International Standards.

Visit www.BrooksInstrument.com to locate the service location nearest to you.

START-UP SERVICE AND IN-SITU CALIBRATION

Brooks Instrument can provide start-up service prior to operation when required.

For some process applications, where ISO-9001 Quality Certification is important, it is mandatory to verify and/or (re)calibrate the products periodically. In many cases this service can be provided under in-situ conditions, and the results will be traceable to the relevant international quality standards.

CUSTOMER SEMINARS AND TRAINING

Brooks Instrument can provide customer seminars and dedicated training to engineers, end users and maintenance persons.

Please contact your nearest sales representative for more details.

HELP DESK

In case you need technical assistance:

Americas  1 888 554 FLOW
Europe  +31 (0) 318 549 290
Asia  +81 (0) 3 5633 7100

Due to Brooks Instrument's commitment to continuous improvement of our products, all specifications are subject to change without notice.



Brooks Instrument
407 West Vine Street
P.O. Box 903
Hatfield, PA 19440-0903 USA
T (215) 362 3700
F (215) 362 3745
E-Mail BrooksAm@BrooksInstrument.com
www.BrooksInstrument.com

Brooks Instrument
Neonstraat 3
6718 WX Ede, Netherlands
T +31 (0) 318 549 300
F +31 (0) 318 549 309
E-Mail BrooksEu@BrooksInstrument.com

Brooks Instrument
1-4-4 Kitasuna Koto-Ku
Tokyo, 136-0073 Japan
T +81 (0) 3 5633 7100
F +81 (0) 3 5633 7101
E-Mail BrooksAs@BrooksInstrument.com